

AVX Tantalum and Niobium Oxide Capacitors



Version 13.6

AVX
A KYOCERA GROUP COMPANY

| | | |
|-----------------------------|--|---------|
| SECTION 1: | SURFACE MOUNT COMMERCIAL TANTALUM | |
| | Introduction | 2-3 |
| | Tantalum and Niobium Road Map | 4-5 |
| General | TAJ Series – Standard Tantalum | 6-10 |
| | TAJ Automotive Series – Standard Tantalum – Automotive Product Range | 11-13 |
| | F93 Series – Resin-Molded Chip, Standard Tantalum J-Lead | 14-15 |
| | F93-AJ6 – Resin-Molded Chip – Automotive Product Range | 16-17 |
| | TAC Series – Standard TACmicrochip® | 18-20 |
| | F95 Series – Standard Conformal Coated Chip | 21-22 |
| Low Profile | TAJ Series – Low Profile | 23-27 |
| | F92 Series – Resin-Molded Chip, Low Profile J-Lead | 28-29 |
| | TAC Series – Low Profile TACmicrochip® | 30-31 |
| HICV | TLJ Series – Tantalum Solid Electrolytic Chip Caps High CV Consumer Series | 32-35 |
| | TLC Series – Tantalum Solid Electrolytic Chip Caps Consumer Series | 36-38 |
| | TLN Series – Tantalum Solid Electrolytic Chip Caps Undertab Series | 39-40 |
| | TLN PulseCap™ Series – High Capacitance Tantalum Solid Electrolytic Chip Caps Undertab Series | 41-42 |
| | F98 Series – Resin-Molded Chip, High CV Frameless® | 43 |
| | F72/F75 Series – Low Profile and HICV Conformal Coated Chip | 44-45 |
| Low ESR | TPS Series – Low ESR | 46-56 |
| | TPS Automotive Series – Low ESR – Automotive Product Range | 57-61 |
| | F91 Series – Low ESR, Resin-Molded Chip J-Lead | 62 |
| | TPM Series – Multianode, Tantalum Ultra Low ESR | 63-65 |
| | TPC Series – Low ESR TACmicrochip® | 66-68 |
| Polymer | TCJ Series – Tantalum Solid Electrolytic Chip Caps w/Conductive Polymer Electrode | 69-74 |
| | TCM Series – Tantalum Solid Electrolytic Chip Caps/Conductive Polymer Multianode | 75-76 |
| | TCN Series – Tantalum Solid Electrolytic Chip Caps Undertab Series w/Conductive Polymer Electrode | 77-78 |
| | F38 Series – Conductive Polymer, Miniature, Frameless® | 79 |
| Performance | TRJ Series – Professional Tantalum | 80-85 |
| | F97 Series – Resin-Molded Chip, Improved Reliability J-Lead | 86-87 |
| | TRM Series – Professional Multianode | 88-90 |
| | THJ Series – High Temperature (up to 175°C) | 91-93 |
| | THJ Series with Extension to 200°C | 94-95 |
| | TAW Series – Fused Tantalum | 96-97 |
| | AUDIO F95 Series – Conformal Coated Chip Optimized for Audio Applications | 98-99 |
| SECTION 2: | NIOBIUM OXIDE - OxiCap® | |
| | NOJ Series – Standard OxiCap® | 100-103 |
| | NOJ Series – Low Profile | 104-106 |
| | NLJ Series – High CV Consumer Series | 107-108 |
| | NOS Series – Low ESR OxiCap® | 109-112 |
| | NOM Series – Low ESR Multianodes | 113-114 |
| SECTION 3: | LEADED TANTALUM | |
| | Introduction | 115 |
| | Dipped Radial Capacitors | 115 |
| | Dipped Radial – TAP/TEP Series Wire Form Outline | 116 |
| | TAP Series | 117-119 |
| | TEP Series | 120-122 |
| | TAP/TEP Series Tape & Reel | 123-124 |
| SECTION 4: | TECHNICAL SUMMARY AND APPLICATION GUIDELINES | |
| | Introduction | 125-126 |
| | Section 1: Electrical Characteristics and Explanation of Terms | 127-131 |
| | Section 2: A.C. Operation, Ripple Voltage and Ripple Current | 132-134 |
| | Section 3: Reliability and Calculation of Failure Rate | 135-137 |
| | Section 4: Application Guidelines for Tantalum and OxiCap® Capacitors | 138 |
| | Section 5: Terminations | 139 |
| | Section 6: Mechanical and Thermal Properties of Capacitors | 140-141 |
| | Section 7: Epoxy Flammability | 141 |
| | Section 8: Qualification Approval Status | 141 |
| | Product Safety and Environmental Information Data | 142-145 |
| | Tantalum & Niobium Oxide Capacitors (excluding F-Series) – Tape & Reel Packaging | 146-149 |
| | F-Series Capacitors – Tape & Reel Packaging | 150 |
| | Tantalum & Niobium Oxide Capacitors – Marking | 151 |
| | TAP/TEP TECHNICAL SUMMARY AND APPLICATION GUIDELINES | |
| | Section 1: Electrical Characteristics and Explanation of Terms | 152-155 |
| | Section 2: A.C. Operation, Ripple Voltage and Ripple Current | 156 |
| | Section 3: Reliability and Calculation of Failure Rate | 157-159 |
| | Section 4: Application Guidelines for Tantalum Capacitors | 160 |
| | Questions and Answers | 161-164 |
| SOFTWARE TOOLS | | 165 |
| PRODUCT LISTING | | 166 |
| RANGE OF SAMPLE KITS | | 167 |

Section 1: Introduction



AVX Tantalum

APPLICATIONS

| | | |
|---|--|---|
|  |  |  |
| Low ESR | Automotive Range | Low ESR |
| Low Profile Case | High Reliability | World's Smallest Tantalum |
| Low Failure Rate | Temperature Stability | 0402 Available |
| High Volumetric Efficiency | ISO/TS 16949 Plant Approved | High Volumetric Efficiency |
| Temperature Stability | Up to 175°C (200°C) | Low Profile Versions |
| Stable over Time | AEC-Q200 Approval | |

QUALITY STATEMENTS

AVX's focus is CUSTOMER satisfaction - customer satisfaction in the broadest sense: product quality, technical support, product availability - all at a competitive price.

In pursuance of the established goals of AVX corporation, it is the stated objective of AVX Tantalum to supply our customers with a world class service in the manufacture and supply of electronic components, while maintaining a positive return on investment.

This world class service shall be defined as consistently supplying product and services of the highest quality and reliability encompassing all aspects of the customer supply chain.

In addition, any new or changed products, processes or services will be qualified to established standards of quality and reliability.

The objectives and guidelines listed above shall be achieved by the following codes of practice:

1. Continual objective evaluation of customer needs and expectations for the future and the leverage of all AVX resources to meet this challenge.

2. Continually fostering and promoting a culture of continuous improvement through ongoing training and empowered participation of employees at all levels of the company.

3. Continuous Process Improvement using sound engineering principles to enhance existing equipment, material and processes. This includes the application of the science of S.P.C. focused on improving the Process Capability Index, Cpk.

The Tantalum division has plants approved to ISO 9001:2008 and ISO/TS 16949:2009 (Automotive Quality System Requirements) with the intention that all facilities world-wide will adopt this as the quality standard.

Dedicated series of tantalum and niobium oxide capacitors meets requirements of AEC-Q200.

The Tantalum division has plants approved to ISO 14001:2004 with the intention that all facilities world-wide will adopt this as the quality standard.



Introduction



AVX Tantalum

AVX Paignton UK is the Divisional Headquarters for the Tantalum division which has manufacturing locations in Biddeford in Maine, USA, Lanskroun in the Czech Republic and San Salvador, in El Salvador. AVX is also pleased to add manufacturing facilities in Adogawa in Japan and Tianjin in China through the recent acquisition of the Tantalum Division of Nichicon Corporation.

This division manufactures tantalum and niobium oxide capacitors. Tantalum is an element extracted from ores found alongside tin and niobium deposits; the major sources of supply are Brazil, Africa and Australasia.

Since December 1st, 2011, AVX has exclusively sourced the tantalum powder and wire used to manufacture its tantalum

capacitors from smelters whose compliance with the Electronic Industry Code of Conduct (EICC) and the Global e-Sustainability Initiative (GeSI) Conflict-Free Smelter program has been verified.

Niobium oxide is a ceramic material that can be processed to the same powder form as traditional tantalum capacitors and manufactured in an identical process.

AVX is No.1 Tantalum capacitor manufacturer with widest range of capacitors from smallest to large case sizes, from consumer to automotive, medical and aerospace level applications. AVX has a leading market position in all world regions. Call us first - **AVX your global partner.**

TECHNOLOGY TRENDS

The amount of capacitance possible with a tantalum capacitor is directly related to the type of tantalum powder used to manufacture the anode.

The following graph shows how the (capacitance) x (voltage) per gram (CV/g) has steadily increased over time, thus allowing the production of larger and larger capacitances with the same physical volume. CV/g is the measure used to define the volumetric efficiency of a powder, a higher CV/g means a higher capacitance from the same volume.

These powder improvements have been achieved through close development with the material suppliers.

AVX Tantalum is committed to driving the available technology forward as is clearly demonstrated by extended ratings continually being developed, and technologies such as TACmicrochip®, OxiCap® and unique Tantalum polymer technology.

If you have any specific requirements, please contact your local AVX sales office for details on how AVX Tantalum can assist you in addressing your future requirements.

WORKING WITH THE CUSTOMER - ONE STOP SHOPPING

In line with our desire to be the number one supplier in the world for passive and interconnection components, AVX is applying continuous improvement policy and development of new innovative technologies.

It is not good enough to market the best products; the customer must have access to a service system which suits his needs and benefits business.

The AVX 'one stop shopping' concept is already beneficial in meeting the needs of major OEMs while worldwide partnerships with only the premier division of distributors aids the smaller user.

Helping to market and support our customers across the breadth and depth of our electronic component line card are

a dedicated team of sales engineers, applications engineers and product marketing managers.

Total quality starts and finishes with our commitment to customer service. Where cost and quality are perceived as given quantities AVX's first in class service invariably places us in the top rank of any preferred supplier list.

Facilities are equipped with instant worldwide DP and telecommunication links connected to every sales and production site worldwide. That ensures our customers' delivery requirements are consistently met wherever in the world they may be.

Tantalum Powder CV/g

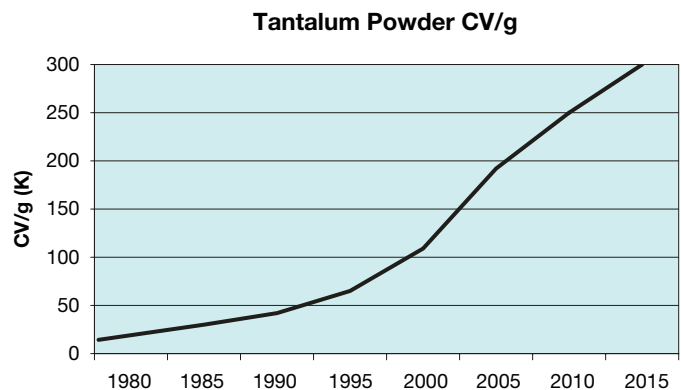

*Niobium Oxide Capacitors are manufactured and sold under patent license from Cabot Corporation, Boyertown, Pennsylvania U.S.A.

Tantalum and Niobium Road Map



| | Tantalum SMD Chip | | | | | | | | | |
|--------------|-------------------------------------|----------------------|-------------------------|-------------------|-----------------|----------------------|------------------|----------------|-------|-------------------------|
| | Standard | Low ESR | Multianodes | Polymer | PulseCap | High CV | CWR 09, 19, 29* | | Fused | Modules |
| | | | | | | | Standard | Low ESR | | |
| Commercial | TAJ | TPS Low ESR | TPM Ultra Low ESR | TCJ | TLN PulseCap | TLJ | | | TAW | |
| | TAJ Low Profile | | | TCM Multianode | | TLN Undertab | | | | |
| | F93 | F91 | | TCN Undertab | | F98 | | | | |
| | F92 Low Profile | | | F38 | | F72/F75 Conformal | | | | |
| | F95 Conformal | | | | | | | | | |
| Professional | TAJ Automotive | TPS Automotive | TRM | TCB | | | | | | |
| | F93-AJ6 | TRJ Low ESR | | | | | | | | |
| | TRJ | | | | | | | | | |
| | F97 | | | | | | | | | |
| High-Temp | THJ 175/200°C | | | | | | | | | |
| CECC | TAJ CECC* 30801-011 30801-005 | | | | | | | | | |
| COTS+* | TBJ | TBJ Low ESR | TBM Ultra Low ESR | TCB | | | TAZ | TAZ | | TCP Ultra Low ESR |
| DSCC* | DSCC 95158 | DSCC 95158 | | | | | | | | DSCC 09009 |
| | DSCC 07016 | DSCC 07016 | | | | | | | | |
| MIL-PRF* | CWR11 | | | | | | CWR09 | CWR29 | | |
| | | | | | | | CWR19 High CV | | | |
| Space Level* | TAJ ESCC ESCC 3012/001 | TBJ SRC9000 | TBM SRC9000 | | | | TAZ SRC9000 | TAZ SRC9000 | | TCP SRC9000 |
| | | TES ESCC 3012-004 | TES ESCC 3012-004 | | | | CWR 'T' Level | CWR 'T' Level | | |
| Medical* | TMJ | TMJ | | | | | TAZ HRC5000 | TAZ HRC5000 | | TCP HRC5000 |

*See High Reliability Tantalum Catalog

NOTE: For specific requirements please contact manufacturer

Under development

| SMD Tantalum Capacitors Series Guide per Construction | | | | | | | |
|---|---------|-------------|--------------|---------|---------|-------------|-----|
| Construction Type / Purpose | General | Low profile | HiCV | Low ESR | Polymer | Performance | |
| J-lead Tantalum | TAJ | TAJ-LP | TLJ | TPS | TCJ | TRJ | |
| | | | | TPM | | TRM | |
| | F93 | F92 | | F91 | TCM | THJ | |
| | | | | | | THJ+ | |
| | | | | | | | F97 |
| | | | | | | | TAW |
| | | | | | TMJ | | |
| J-lead NbO | NOJ | NOJ-LP | NLJ | NOS | | | |
| | | | | NOM | | | |
| TACmicrochip® | TAC | TAC-LP | TLC | TPC | | TMC | |
| Undertab, Frameless | | | TLN | | TCN | | |
| | | | TLN PulseCap | | | | |
| | | | F98 | | F38 | | |
| Conformal | F95 | | F72/F75 | | | AUDIO F95 | |



Tantalum and Niobium Road Map



| | TACmicrochip® | | | Leaded | | | Hermetic Sealed* | | Niobium OxiCap® | | |
|--------------|---------------|-----------------------------------|---------|--------------------|----------------------------|--------------|------------------|------------------|-----------------|---------|------------|
| | High CV | Standard | Low ESR | Resin Dipped | Wet* | Wet* Modules | Polymer | MnO ₂ | Standard | Low ESR | Multianode |
| Commercial | TLC | TAC | TPC | TAP/TEP Radial | | | | | NOJ NLJ | NOS | NOM |
| Professional | | | | | | | TCH | THH | NOJ | NOS | NOM |
| High-Temp | | | | | TWA-Y 200°C TWC-Y 200°C | | | THH 230°C | | | |
| CECC | | | | TAP CECC 30201-032 | TWA-E TWC-E | | | | | | |
| COTS+* | | TBC | | | TWA-S TWC-S | TWM | TCH | THH | | NBS | NBM |
| DSCC* | | | | | DSCC 93026 | | | | | | |
| MIL-PRF* | | CWR15 | | | M39006 | | | | | | |
| Space Level* | | TBC SRC9000 | | | SRW 9000 | TWM | TCH 3012-005 | | | | |
| Medical* | | TBC HRC5000 TBC HRC6000 TMC | | | | | | | | | |

*See High Reliability Tantalum Catalog

NOTE: For specific requirements please contact manufacturer

Under development

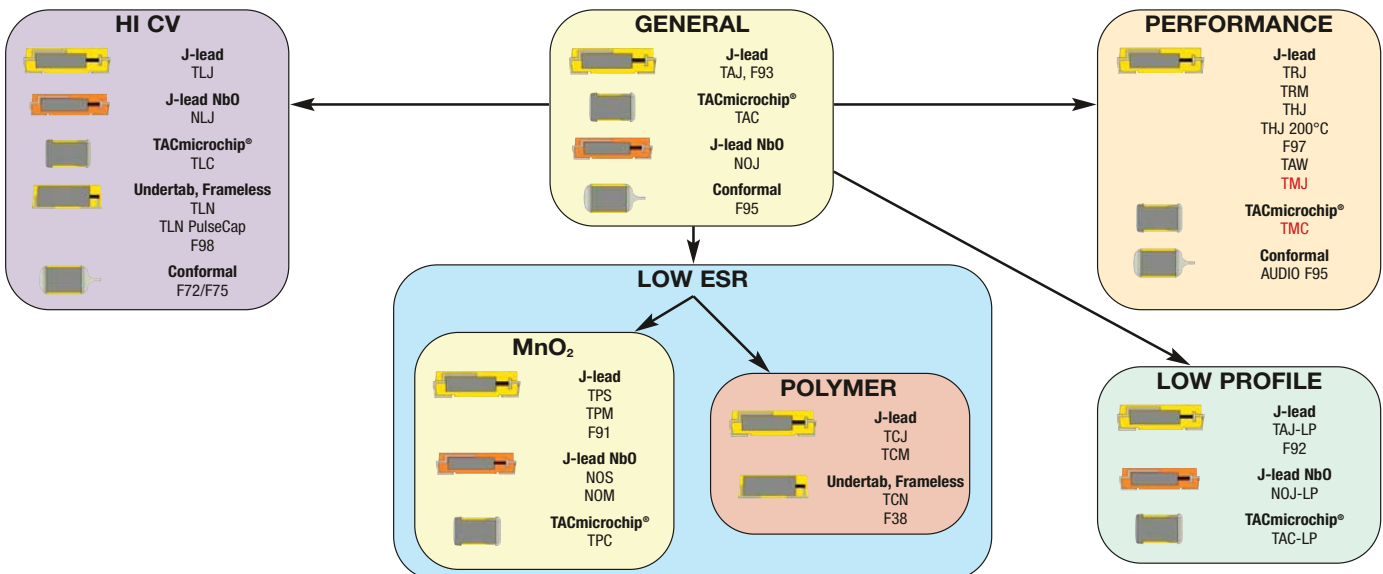

TAJ Series

Standard Tantalum



- General purpose SMT chip tantalum series
- 7 case sizes available
- Low profile options available
- CV range: 0.10-2200 μ F / 2.5-50V



SnPb termination option is not RoHS compliant.

CASE DIMENSIONS: millimeters (inches)

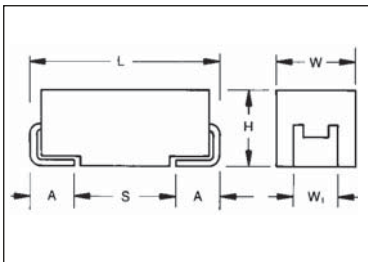

For part marking see page 151

| Code | EIA Code | EIA Metric | L \pm 0.20 (0.008) | W+0.20 (0.008) -0.10 (0.004) | H+0.20 (0.008) -0.10 (0.004) | W _t \pm 0.20 (0.008) | A+0.30 (0.012) -0.20 (0.008) | S Min. |
|------|----------|------------|----------------------|------------------------------|------------------------------|-----------------------------------|------------------------------|--------------|
| A | 1206 | 3216-18 | 3.20 (0.126) | 1.60 (0.063) | 1.60 (0.063) | 1.20 (0.047) | 0.80 (0.031) | 1.10 (0.043) |
| B | 1210 | 3528-21 | 3.50 (0.138) | 2.80 (0.110) | 1.90 (0.075) | 2.20 (0.087) | 0.80 (0.031) | 1.40 (0.055) |
| C | 2312 | 6032-28 | 6.00 (0.236) | 3.20 (0.126) | 2.60 (0.102) | 2.20 (0.087) | 1.30 (0.051) | 2.90 (0.114) |
| D | 2917 | 7343-31 | 7.30 (0.287) | 4.30 (0.169) | 2.90 (0.114) | 2.40 (0.094) | 1.30 (0.051) | 4.40 (0.173) |
| E | 2917 | 7343-43 | 7.30 (0.287) | 4.30 (0.169) | 4.10 (0.162) | 2.40 (0.094) | 1.30 (0.051) | 4.40 (0.173) |
| U | 2924 | 7361-43 | 7.30 (0.287) | 6.10 (0.240) | 4.10 (0.162) | 3.10 (0.120) | 1.30 (0.051) | 4.40 (0.173) |
| V | 2924 | 7361-38 | 7.30 (0.287) | 6.10 (0.240) | 3.55 (0.140) | 3.10 (0.120) | 1.30 (0.051) | 4.40 (0.173) |

W_t: dimension applies to the termination width for A dimensional area only.

HOW TO ORDER

| | | | | | | | |
|-------------|-------------------------------------|---|--|---|--|---|---|
| TAJ | C | 106 | M | 035 | R | NJ | - |
| Type | Case Size See table above | Capacitance Code pF code: 1st two digits represent significant figures 3rd digit represents multiplier (number of zeros to follow) | Tolerance K= \pm 10% M= \pm 20% | Rated DC Voltage 002=2.5Vdc 004=4Vdc 006=6.3Vdc 010=10Vdc 016=16Vdc 020=20Vdc 025=25Vdc 035=35Vdc 050=50Vdc | Packaging R = Pure Tin 7" Reel S = Pure Tin 13" Reel A = Gold Plating 7" Reel B = Gold Plating 13" Reel H = Tin Lead 7" Reel (Contact Manufacturer) K = Tin Lead 13" Reel (Contact Manufacturer) H, K = Non RoHS | Specification Suffix NJ = Standard Suffix | Additional characters may be added for special requirements V = Dry pack Option (selected codes only) |

TECHNICAL SPECIFICATIONS

| | | | | | | | | | | | |
|------------------------------------|--|-----|-----|-----|----|----|----|----|----|----|--|
| Technical Data: | All technical data relate to an ambient temperature of +25°C | | | | | | | | | | |
| Capacitance Range: | 0.10 μ F to 2200 μ F | | | | | | | | | | |
| Capacitance Tolerance: | \pm 10%; \pm 20% | | | | | | | | | | |
| Rated Voltage (V _R) | \leq +85°C: | 2.5 | 4 | 6.3 | 10 | 16 | 20 | 25 | 35 | 50 | |
| Category Voltage (V _C) | \leq +125°C: | 1.7 | 2.7 | 4 | 7 | 10 | 13 | 17 | 23 | 33 | |
| Surge Voltage (V _S) | \leq +85°C: | 3.3 | 5.2 | 8 | 13 | 20 | 26 | 32 | 46 | 65 | |
| Surge Voltage (V _S) | \leq +125°C: | 2.2 | 3.4 | 5 | 8 | 13 | 16 | 20 | 28 | 40 | |
| Temperature Range: | -55°C to +125°C | | | | | | | | | | |
| Reliability: | 1% per 1000 hours at 85°C, V _R with 0.1 Ω /V series impedance, 60% confidence level | | | | | | | | | | |
| Qualification: | CECC 30801 - 005 issue 2 EIA 535BAAC | | | | | | | | | | |
| Termination Finished: | Sn Plating (standard), Gold and SnPb Plating upon request For AEC-Q200 availability, please contact AVX | | | | | | | | | | |



Standard Tantalum

CAPACITANCE AND RATED VOLTAGE, VR (VOLTAGE CODE) RANGE (LETTER DENOTES CASE SIZE)

| Capacitance | | Rated voltage DC (V _R) to 85°C | | | | | | | | |
|-------------|------|--|-----------------------|------------------------------------|-------------------------|-----------------------|------------------------|---------------------|---------|-----------------------|
| µF | Code | 2.5V (e) | 4V (G) | 6.3V (J) | 10V (A) | 16V (C) | 20V (D) | 25V (E) | 35V (V) | 50V (T) |
| 0.10 | 104 | | | | | | | | A | A |
| 0.15 | 154 | | | | | | | | A | A/B |
| 0.22 | 224 | | | | | | | | A | A/B |
| 0.33 | 334 | | | | | | | A | A | A/B |
| 0.47 | 474 | | | | | | A | A | A/B | A/B/C |
| 0.68 | 684 | | | | | | A | A | A/B | A/B/C |
| 1.0 | 105 | | | | | A | A | A | A/B | A ^(M) /B/C |
| 1.5 | 155 | | | | A | A | A | A/B | A/B/C | B/C/D |
| 2.2 | 225 | | | A | A | A/B | A/B | A/B | A/B/C | B/C/D |
| 3.3 | 335 | | A | A | A | A/B | A/B | A/B/C | B/C | C/D |
| 4.7 | 475 | | A | A | A/B | A/B | A/B/C | A/B/C | B/C/D | C/D |
| 6.8 | 685 | | A | A/B | A/B | A/B/C | A/B/C | B/C | C/D | C/D |
| 10 | 106 | | A | A/B | A/B/C | A/B/C | A ^(M) */B/C | B/C/D | C/D/E | D/E/V |
| 15 | 156 | | A/B | A/B | A/B/C | A ^(M) /B/C | B/C/D | C/D | C/D | D/E/V |
| 22 | 226 | | A | A/B/C | A/B/C | B/C/D | B/C/D | C/D | D/E | V |
| 33 | 336 | A | A/B | A/B/C | A/B/C/D | B/C/D | C/D | D/E | D/E/V | |
| 47 | 476 | A | A/B | A/B/C/D | B/C/D | C/D | C/D/E | D/E | E/V | |
| 68 | 686 | A | A/B/C | B/C/D | B/C/D | C/D | C ^(M) /D/E | E/V | V | |
| 100 | 107 | A/B | A/B/C | B/C/D | B ^(M) /C/D/E | C/D/E | D/E/V | E ^(M) /V | | |
| 150 | 157 | B | B/C | B ^(M) /C/D | C/D/E | D/E/V | E/V | V ^(M) | | |
| 220 | 227 | B/D | B ^(M) /C/D | C/D/E | C/D/E | E/V | | | | |
| 330 | 337 | D | C/D/E | C/D/E | D/E/V | E ^(M) | | | | |
| 470 | 477 | C/D | C/D/E | D/E/V | E/U/V | | | | | |
| 680 | 687 | C/D/E | D/E | E/V | | | | | | |
| 1000 | 108 | D ^(M) /E | D/E/V | E ^(M) /V ^(M) | | | | | | |
| 1500 | 158 | D/E/V ^(M) | E/V ^(M) | | | | | | | |
| 2200 | 228 | V ^(M) | | | | | | | | |

Not recommended for new designs, higher voltage or smaller case size substitution are offered.

Released codes ^(M tolerance only)

Engineering samples - please contact manufacturer

*Codes under development - subject to change

Note: Voltage ratings are minimum values. AVX reserves the right to supply higher ratings in the same case size, to the same reliability standards.

TAJ Series

Standard Tantalum



RATINGS & PART NUMBER REFERENCE

| AVX Part No. | Case Size | Cap (µF) | Rated Voltage (V) | DCL (µA) Max. | DF % Max. | ESR Max. (Ω) @100kHz | MSL |
|---|-----------|----------|-------------------|---------------|-----------|----------------------|-----------------|
| 2.5 Volt @ 85°C (1.7 Volt @ 125°C) | | | | | | | |
| TAJA336*002#NJ | A | 33 | 2.5 | 0.8 | 8 | 1.7 | 1 |
| TAJA476*002#NJ | A | 47 | 2.5 | 0.9 | 6 | 3 | 1 |
| TAJA686*002#NJ | A | 68 | 2.5 | 1.4 | 8 | 1.5 | 1 |
| TAJA107*002#NJ | A | 100 | 2.5 | 2.5 | 30 | 1.4 | 1 |
| TAJB107*002#NJ | B | 100 | 2.5 | 2.5 | 8 | 1.4 | 1 |
| TAJB157*002#NJ | B | 150 | 2.5 | 3 | 10 | 1.6 | 1 |
| TAJB227*002#NJ | B | 220 | 2.5 | 4.4 | 16 | 1.6 | 1 |
| TAJD227*002#NJ | D | 220 | 2.5 | 5.5 | 8 | 0.3 | 1 |
| TAJD337*002#NJ | D | 330 | 2.5 | 8.2 | 8 | 0.3 | 1 |
| TAJC477*002#NJ | C | 470 | 2.5 | 9.4 | 12 | 0.2 | 1 |
| TAJD477*002#NJ | D | 470 | 2.5 | 11.6 | 8 | 0.2 | 1 |
| TAJC687*002#NJ | C | 680 | 2.5 | 17.0 | 18 | 0.2 | 1 |
| TAJD687*002#NJ | D | 680 | 2.5 | 17 | 16 | 0.2 | 1 |
| TAJE687*002#NJ | E | 680 | 2.5 | 17 | 10 | 0.2 | 1 ¹⁾ |
| TAJD108M002#NJ | D | 1000 | 2.5 | 25 | 20 | 0.2 | 1 |
| TAJE108*002#NJ | E | 1000 | 2.5 | 20 | 14 | 0.4 | 1 ¹⁾ |
| TAJD158*002#NJ | D | 1500 | 2.5 | 37.5 | 60 | 0.2 | 1 |
| TAJE158*002#NJ | E | 1500 | 2.5 | 37 | 20 | 0.2 | 1 ¹⁾ |
| TAJV158M002#NJ | V | 1500 | 2.5 | 30 | 20 | 0.2 | 1 ¹⁾ |
| TAJV228M002#NJ | V | 2200 | 2.5 | 55 | 50 | 0.2 | 1 ¹⁾ |
| 4 Volt @ 85°C (2.7 Volt @ 125°C) | | | | | | | |
| TAJA336*004#NJ | A | 33 | 4 | 1.3 | 6 | 3 | 1 |
| TAJA476*004#NJ | A | 47 | 4 | 1.9 | 8 | 2.6 | 1 |
| TAJA686*004#NJ | A | 68 | 4 | 2.7 | 10 | 1.5 | 1 |
| TAJB686*004#NJ | B | 68 | 4 | 2.7 | 6 | 1.8 | 1 |
| TAJA107*004#NJ | A | 100 | 4 | 4 | 30 | 1.4 | 1 |
| TAJB107*004#NJ | B | 100 | 4 | 4 | 8 | 0.9 | 1 |
| TAJB157*004#NJ | B | 150 | 4 | 6 | 10 | 1.5 | 1 |
| TAJC157*004#NJ | C | 150 | 4 | 6 | 6 | 0.3 | 1 |
| TAJB227M004#NJ | B | 220 | 4 | 8.8 | 12 | 1.1 | 1 |
| TAJC227*004#NJ | C | 220 | 4 | 8.8 | 8 | 1.2 | 1 |
| TAJD227*004#NJ | D | 220 | 4 | 8.8 | 8 | 0.9 | 1 |
| TAJC337*004#NJ | C | 330 | 4 | 13.2 | 8 | 0.3 | 1 |
| TAJD337*004#NJ | D | 330 | 4 | 13.2 | 8 | 0.9 | 1 |
| TAJC477*004#NJ | C | 470 | 4 | 18.8 | 14 | 0.3 | 1 |
| TAJD477*004#NJ | D | 470 | 4 | 18.8 | 12 | 0.9 | 1 |
| TAJE477*004#NJ | E | 470 | 4 | 18.8 | 10 | 0.5 | 1 ¹⁾ |
| TAJD687*004#NJ | D | 680 | 4 | 27.2 | 14 | 0.5 | 1 |
| TAJE687*004#NJ | E | 680 | 4 | 27.2 | 14 | 0.9 | 1 ¹⁾ |
| TAJD108*004#NJ | D | 1000 | 4 | 40 | 60 | 0.2 | 1 |
| TAJE108*004#NJ | E | 1000 | 4 | 40 | 14 | 0.4 | 1 ¹⁾ |
| TAJV108*004#NJ | V | 1000 | 4 | 40 | 16 | 0.2 | 1 ¹⁾ |
| TAJE158*004#NJ | E | 1500 | 4 | 60 | 30 | 0.2 | 1 ¹⁾ |
| TAJV158M004#NJ | V | 1500 | 4 | 60 | 30 | 0.2 | 1 ¹⁾ |
| 6.3 Volt @ 85°C (4 Volt @ 125°C) | | | | | | | |
| TAJA106*006#NJ | A | 10 | 6.3 | 0.6 | 6 | 4 | 1 |
| TAJA156*006#NJ | A | 15 | 6.3 | 0.9 | 6 | 3.5 | 1 |
| TAJA226*006#NJ | A | 22 | 6.3 | 1.4 | 6 | 3 | 1 |
| TAJA336*006#NJ | A | 33 | 6.3 | 2.1 | 8 | 2.2 | 1 |
| TAJA476*006#NJ | A | 47 | 6.3 | 2.8 | 10 | 1.6 | 1 |
| TAJB476*006#NJ | B | 47 | 6.3 | 3 | 6 | 2 | 1 |
| TAJC476*006#NJ | C | 47 | 6.3 | 3 | 6 | 1.6 | 1 |
| TAJB686*006#NJ | B | 68 | 6.3 | 4 | 8 | 0.9 | 1 |
| TAJC686*006#NJ | C | 68 | 6.3 | 4.3 | 6 | 1.5 | 1 |
| TAJB107*006#NJ | B | 100 | 6.3 | 6.3 | 10 | 1.7 | 1 |
| TAJC107*006#NJ | C | 100 | 6.3 | 6.3 | 6 | 0.9 | 1 |
| TAJB157M006#NJ | B | 150 | 6.3 | 9.5 | 10 | 1.2 | 1 |
| TAJC157*006#NJ | C | 150 | 6.3 | 9.5 | 6 | 1.3 | 1 |

| AVX Part No. | Case Size | Cap (µF) | Rated Voltage (V) | DCL (µA) Max. | DF % Max. | ESR Max. (Ω) @100kHz | MSL |
|---|-----------|----------|-------------------|---------------|-----------|----------------------|-----------------|
| TAJD157*006#NJ | D | 150 | 6.3 | 9.5 | 6 | 0.9 | 1 |
| TAJC227*006#NJ | C | 220 | 6.3 | 13.9 | 8 | 1.2 | 1 |
| TAJD227*006#NJ | D | 220 | 6.3 | 13.9 | 8 | 0.4 | 1 |
| TAJE227*006#NJ | E | 220 | 6.3 | 13.9 | 8 | 0.4 | 1 ¹⁾ |
| TAJC337*006#NJ | C | 330 | 6.3 | 19.8 | 12 | 0.5 | 1 |
| TAJD337*006#NJ | D | 330 | 6.3 | 20.8 | 8 | 0.4 | 1 |
| TAJE337*006#NJ | E | 330 | 6.3 | 20.8 | 8 | 0.4 | 1 ¹⁾ |
| TAJD477*006#NJ | D | 470 | 6.3 | 28 | 12 | 0.4 | 1 |
| TAJE477*006#NJ | E | 470 | 6.3 | 28 | 10 | 0.4 | 1 ¹⁾ |
| TAJV477*006#NJ | V | 470 | 6.3 | 28 | 10 | 0.4 | 1 ¹⁾ |
| TAJE687*006#NJ | E | 680 | 6.3 | 42.8 | 10 | 0.5 | 1 ¹⁾ |
| TAJV687*006#NJ | V | 680 | 6.3 | 42.8 | 10 | 0.5 | 1 ¹⁾ |
| TAJE108M006#NJ | E | 1000 | 6.3 | 60 | 20 | 0.2 | 1 ¹⁾ |
| TAJV108M006#NJ | V | 1000 | 6.3 | 60 | 16 | 0.2 | 1 ¹⁾ |
| 10 Volt @ 85°C (7 Volt @ 125°C) | | | | | | | |
| TAJA475*010#NJ | A | 4.7 | 10 | 0.5 | 6 | 5 | 1 |
| TAJA685*010#NJ | A | 6.8 | 10 | 0.7 | 6 | 4 | 1 |
| TAJA106*010#NJ | A | 10 | 10 | 1 | 6 | 3 | 1 |
| TAJA156*010#NJ | A | 15 | 10 | 1.5 | 6 | 3.2 | 1 |
| TAJB156*010#NJ | B | 15 | 10 | 1.5 | 6 | 2.8 | 1 |
| TAJA226*010#NJ | A | 22 | 10 | 2.2 | 8 | 3 | 1 |
| TAJB226*010#NJ | B | 22 | 10 | 2.2 | 6 | 2.4 | 1 |
| TAJA336*010#NJ | A | 33 | 10 | 3.3 | 8 | 1.7 | 1 |
| TAJB336*010#NJ | B | 33 | 10 | 3.3 | 6 | 1.8 | 1 |
| TAJC336*010#NJ | C | 33 | 10 | 3.3 | 6 | 1.6 | 1 |
| TAJB476*010#NJ | B | 47 | 10 | 4.7 | 8 | 1 | 1 |
| TAJC476*010#NJ | C | 47 | 10 | 4.7 | 6 | 1.2 | 1 |
| TAJB686*010#NJ | B | 68 | 10 | 6.8 | 6 | 1.4 | 1 |
| TAJC686*010#NJ | C | 68 | 10 | 6.8 | 6 | 1.3 | 1 |
| TAJB107M010#NJ | B | 100 | 10 | 10 | 8 | 1.4 | 1 |
| TAJC107*010#NJ | C | 100 | 10 | 10 | 8 | 1.2 | 1 |
| TAJD107*010#NJ | D | 100 | 10 | 10 | 6 | 0.9 | 1 |
| TAJC157*010#NJ | C | 150 | 10 | 15 | 8 | 0.9 | 1 |
| TAJD157*010#NJ | D | 150 | 10 | 15 | 8 | 0.9 | 1 |
| TAJE157*010#NJ | E | 150 | 10 | 15 | 8 | 0.9 | 1 ¹⁾ |
| TAJC227*010#NJ | C | 220 | 10 | 22 | 16 | 0.5 | 1 |
| TAJD227*010#NJ | D | 220 | 10 | 22 | 8 | 0.5 | 1 |
| TAJE227*010#NJ | E | 220 | 10 | 22 | 8 | 0.5 | 1 ¹⁾ |
| TAJD337*010#NJ | D | 330 | 10 | 33 | 8 | 0.9 | 1 |
| TAJE337*010#NJ | E | 330 | 10 | 33 | 8 | 0.9 | 1 ¹⁾ |
| TAJV337*010#NJ | V | 330 | 10 | 33 | 10 | 0.9 | 1 ¹⁾ |
| TAJE477*010#NJ | E | 470 | 10 | 47 | 10 | 0.5 | 1 ¹⁾ |
| TAJU477*010RNJ | U | 470 | 10 | 47 | 12 | 0.5 | 1 ¹⁾ |
| TAJV477*010#NJ | V | 470 | 10 | 47 | 10 | 0.5 | 1 ¹⁾ |
| 16 Volt @ 85°C (10 Volt @ 125°C) | | | | | | | |
| TAJA225*016#NJ | A | 2.2 | 16 | 0.5 | 6 | 6.5 | 1 |
| TAJA335*016#NJ | A | 3.3 | 16 | 0.5 | 6 | 5 | 1 |
| TAJB335*016#NJ | B | 3.3 | 16 | 0.5 | 6 | 4.5 | 1 |
| TAJA475*016#NJ | A | 4.7 | 16 | 0.8 | 6 | 4 | 1 |
| TAJB475*016#NJ | B | 4.7 | 16 | 0.8 | 6 | 3.5 | 1 |
| TAJA685*016#NJ | A | 6.8 | 16 | 1.1 | 6 | 3.5 | 1 |
| TAJB685*016#NJ | B | 6.8 | 16 | 1.1 | 6 | 2.5 | 1 |
| TAJA106*016#NJ | A | 10 | 16 | 1.6 | 6 | 3 | 1 |
| TAJB106*016#NJ | B | 10 | 16 | 1.6 | 6 | 2.8 | 1 |
| TAJC106*016#NJ | C | 10 | 16 | 1.6 | 6 | 2 | 1 |
| TAJA156M016#NJ | A | 15 | 16 | 2.4 | 6 | 2 | 1 |
| TAJB156*016#NJ | B | 15 | 16 | 2.4 | 6 | 2.5 | 1 |
| TAJC156*016#NJ | C | 15 | 16 | 2.4 | 6 | 1.8 | 1 |
| TAJB226*016#NJ | B | 22 | 16 | 3.5 | 6 | 2.3 | 1 |
| TAJC226*016#NJ | C | 22 | 16 | 3.5 | 6 | 1 | 1 |

¹⁾ Dry pack option (see How to order) recommended for reduction of stress during soldering. Dry pack parts should be treated as MSL 3.

Moisture Sensitivity Level (MSL) is defined according to J-STD-020.

For AEC-Q200 availability, please contact AVX.

All technical data relates to an ambient temperature of +25°C. Capacitance and DF are measured at 120Hz, 0.5V RMS with a maximum DC bias of 2.2 volts.

DCL is measured at rated voltage after 5 minutes.

For typical weight and composition see page 144.

NOTE: AVX reserves the right to supply a higher voltage rating or tighter tolerance part in the same case size, to the same reliability standards.



RATINGS & PART NUMBER REFERENCE

| AVX Part No. | Case Size | Cap (µF) | Rated Voltage (V) | DCL (µA) Max. | DF % Max. | ESR Max. (Ω) @100kHz | MSL |
|---|-----------|----------|-------------------|---------------|-----------|----------------------|-----------------|
| TAJD226*016#NJ | D | 22 | 16 | 3.5 | 6 | 1.1 | 1 |
| TAJB336*016#NJ | B | 33 | 16 | 5.3 | 8 | 2.1 | 1 |
| TAJC336*016#NJ | C | 33 | 16 | 5.3 | 6 | 1.5 | 1 |
| TAJD336*016#NJ | D | 33 | 16 | 5.3 | 6 | 0.9 | 1 |
| TAJC476*016#NJ | C | 47 | 16 | 7.5 | 6 | 0.5 | 1 |
| TAJD476*016#NJ | D | 47 | 16 | 7.5 | 6 | 0.9 | 1 |
| TAJC686*016#NJ | C | 68 | 16 | 10.9 | 6 | 1.3 | 1 |
| TAJD686*016#NJ | D | 68 | 16 | 10.9 | 6 | 0.9 | 1 |
| TAJC107*016#NJ | C | 100 | 16 | 16 | 8 | 1 | 1 |
| TAJD107*016#NJ | D | 100 | 16 | 16 | 6 | 0.6 | 1 |
| TAJE107*016#NJ | E | 100 | 16 | 16 | 6 | 0.9 | 1 ¹⁾ |
| TAJD157*016#NJ | D | 150 | 16 | 24 | 6 | 0.9 | 1 |
| TAJE157*016#NJ | E | 150 | 16 | 23 | 8 | 0.3 | 1 ¹⁾ |
| TAJV157*016#NJ | V | 150 | 16 | 24 | 8 | 0.5 | 1 ¹⁾ |
| TAJE227*016#NJ | E | 220 | 16 | 35.2 | 10 | 0.5 | 1 ¹⁾ |
| TAJV227*016#NJ | V | 220 | 16 | 35.2 | 8 | 0.9 | 1 ¹⁾ |
| TAJE337M016#NJ | E | 330 | 16 | 52.8 | 30 | 0.4 | 1 ¹⁾ |
| 20 Volt @ 85°C (13 Volt @ 125°C) | | | | | | | |
| TAJA105*020#NJ | A | 1 | 20 | 0.5 | 4 | 9 | 1 |
| TAJA155*020#NJ | A | 1.5 | 20 | 0.5 | 6 | 6.5 | 1 |
| TAJA225*020#NJ | A | 2.2 | 20 | 0.5 | 6 | 5.3 | 1 |
| TAJB225*020#NJ | B | 2.2 | 20 | 0.5 | 6 | 3.5 | 1 |
| TAJA335*020#NJ | A | 3.3 | 20 | 0.7 | 6 | 4.5 | 1 |
| TAJB335*020#NJ | B | 3.3 | 20 | 0.7 | 6 | 3 | 1 |
| TAJA475*020#NJ | A | 4.7 | 20 | 0.9 | 6 | 4 | 1 |
| TAJB475*020#NJ | B | 4.7 | 20 | 0.9 | 6 | 3 | 1 |
| TAJA685*020#NJ | A | 6.8 | 20 | 1.4 | 6 | 2.4 | 1 |
| TAJB685*020#NJ | B | 6.8 | 20 | 1.4 | 6 | 2.5 | 1 |
| TAJC685*020#NJ | C | 6.8 | 20 | 1.4 | 6 | 2 | 1 |
| TAJB106*020#NJ | B | 10 | 20 | 2 | 6 | 2.1 | 1 |
| TAJC106*020#NJ | C | 10 | 20 | 2 | 6 | 1.2 | 1 |
| TAJB156*020#NJ | B | 15 | 20 | 3 | 6 | 2 | 1 |
| TAJC156*020#NJ | C | 15 | 20 | 3 | 6 | 1.7 | 1 |
| TAJB226*020#NJ | B | 22 | 20 | 4.4 | 6 | 1.8 | 1 |
| TAJC226*020#NJ | C | 22 | 20 | 4.4 | 6 | 1.6 | 1 |
| TAJD226*020#NJ | D | 22 | 20 | 4.4 | 6 | 0.9 | 1 |
| TAJC336*020#NJ | C | 33 | 20 | 6.6 | 6 | 1.5 | 1 |
| TAJD336*020#NJ | D | 33 | 20 | 6.6 | 6 | 0.9 | 1 |
| TAJC476*020#NJ | C | 47 | 20 | 9.4 | 6 | 0.5 | 1 |
| TAJD476*020#NJ | D | 47 | 20 | 9.4 | 6 | 0.9 | 1 |
| TAJE476*020#NJ | E | 47 | 20 | 9.4 | 6 | 0.9 | 1 ¹⁾ |
| TAJC686M020#NJ | C | 68 | 20 | 13.6 | 8 | 0.5 | 1 |
| TAJD686*020#NJ | D | 68 | 20 | 13.6 | 6 | 0.4 | 1 |
| TAJE686*020#NJ | E | 68 | 20 | 13.6 | 6 | 0.9 | 1 ¹⁾ |
| TAJD107*020#NJ | D | 100 | 20 | 20 | 6 | 0.5 | 1 |
| TAJE107*020#NJ | E | 100 | 20 | 20 | 6 | 0.4 | 1 ¹⁾ |
| TAJV107*020#NJ | V | 100 | 20 | 20 | 8 | 0.9 | 1 ¹⁾ |
| TAJE157*020#NJ | E | 150 | 20 | 30 | 8 | 0.3 | 1 ¹⁾ |
| TAJV157*020#NJ | V | 150 | 20 | 30 | 8 | 0.3 | 1 ¹⁾ |
| 25 Volt @ 85°C (17 Volt @ 125°C) | | | | | | | |
| TAJA474*025#NJ | A | 0.47 | 25 | 0.5 | 4 | 14 | 1 |
| TAJA684*025#NJ | A | 0.68 | 25 | 0.5 | 4 | 10 | 1 |
| TAJA105*025#NJ | A | 1 | 25 | 0.5 | 4 | 8 | 1 |
| TAJA155*025#NJ | A | 1.5 | 25 | 0.5 | 6 | 7.5 | 1 |
| TAJB155*025#NJ | B | 1.5 | 25 | 0.5 | 6 | 5 | 1 |
| TAJA225*025#NJ | A | 2.2 | 25 | 0.6 | 6 | 7 | 1 |
| TAJB225*025#NJ | B | 2.2 | 25 | 0.6 | 6 | 4.5 | 1 |
| TAJA335*025#NJ | A | 3.3 | 25 | 0.8 | 6 | 3.7 | 1 |

| AVX Part No. | Case Size | Cap (µF) | Rated Voltage (V) | DCL (µA) Max. | DF % Max. | ESR Max. (Ω) @100kHz | MSL |
|---|-----------|----------|-------------------|---------------|-----------|----------------------|-----------------|
| TAJB335*025#NJ | B | 3.3 | 25 | 0.8 | 6 | 3.5 | 1 |
| TAJA475*025#NJ | A | 4.7 | 25 | 1.2 | 6 | 3.1 | 1 |
| TAJB475*025#NJ | B | 4.7 | 25 | 1.2 | 6 | 1.5 | 1 |
| TAJB685*025#NJ | B | 6.8 | 25 | 1.7 | 6 | 2.8 | 1 |
| TAJC685*025#NJ | C | 6.8 | 25 | 1.7 | 6 | 2 | 1 |
| TAJB106*025#NJ | B | 10 | 25 | 2.5 | 6 | 2.5 | 1 |
| TAJC106*025#NJ | C | 10 | 25 | 2.5 | 6 | 1.8 | 1 |
| TAJD106*025#NJ | D | 10 | 25 | 2.5 | 6 | 1.2 | 1 |
| TAJC156*025#NJ | C | 15 | 25 | 3.8 | 6 | 1.6 | 1 |
| TAJD156*025#NJ | D | 15 | 25 | 3.8 | 6 | 1 | 1 |
| TAJC226*025#NJ | C | 22 | 25 | 5.5 | 6 | 1.4 | 1 |
| TAJD226*025#NJ | D | 22 | 25 | 5.5 | 6 | 0.9 | 1 |
| TAJD336*025#NJ | D | 33 | 25 | 8.3 | 6 | 0.9 | 1 |
| TAJE336*025#NJ | E | 33 | 25 | 8.3 | 6 | 0.9 | 1 ¹⁾ |
| TAJD476*025#NJ | D | 47 | 25 | 11.8 | 6 | 0.9 | 1 |
| TAJE476*025#NJ | E | 47 | 25 | 11.8 | 6 | 0.9 | 1 ¹⁾ |
| TAJE686*025#NJ | E | 68 | 25 | 17 | 6 | 0.9 | 1 ¹⁾ |
| TAJV686*025#NJ | V | 68 | 25 | 17 | 6 | 0.9 | 1 ¹⁾ |
| TAJE107M025#NJ | E | 100 | 25 | 25 | 10 | 0.3 | 1 ¹⁾ |
| TAJV107*025#NJ | V | 100 | 25 | 25 | 8 | 0.4 | 1 ¹⁾ |
| TAJV157M025#NJ | V | 150 | 25 | 37.5 | 10 | 0.4 | 1 ¹⁾ |
| 35 Volt @ 85°C (23 Volt @ 125°C) | | | | | | | |
| TAJA104*035#NJ | A | 0.1 | 35 | 0.5 | 4 | 24 | 1 |
| TAJA154*035#NJ | A | 0.15 | 35 | 0.5 | 4 | 21 | 1 |
| TAJA224*035#NJ | A | 0.22 | 35 | 0.5 | 4 | 18 | 1 |
| TAJA334*035#NJ | A | 0.33 | 35 | 0.5 | 4 | 15 | 1 |
| TAJA474*035#NJ | A | 0.47 | 35 | 0.5 | 4 | 12 | 1 |
| TAJB474*035#NJ | B | 0.47 | 35 | 0.5 | 4 | 10 | 1 |
| TAJA684*035#NJ | A | 0.68 | 35 | 0.5 | 4 | 8 | 1 |
| TAJB684*035#NJ | B | 0.68 | 35 | 0.5 | 4 | 8 | 1 |
| TAJA105*035#NJ | A | 1 | 35 | 0.5 | 4 | 7.5 | 1 |
| TAJB105*035#NJ | B | 1 | 35 | 0.5 | 4 | 6.5 | 1 |
| TAJA155*035#NJ | A | 1.5 | 35 | 0.5 | 6 | 7.5 | 1 |
| TAJB155*035#NJ | B | 1.5 | 35 | 0.5 | 6 | 5.2 | 1 |
| TAJC155*035#NJ | C | 1.5 | 35 | 0.5 | 6 | 4.5 | 1 |
| TAJA225*035#NJ | A | 2.2 | 35 | 0.8 | 6 | 4.5 | 1 |
| TAJB225*035#NJ | B | 2.2 | 35 | 0.8 | 6 | 4.2 | 1 |
| TAJC225*035#NJ | C | 2.2 | 35 | 0.8 | 6 | 3.5 | 1 |
| TAJB335*035#NJ | B | 3.3 | 35 | 1.2 | 6 | 3.5 | 1 |
| TAJC335*035#NJ | C | 3.3 | 35 | 1.2 | 6 | 2.5 | 1 |
| TAJB475*035#NJ | B | 4.7 | 35 | 1.6 | 6 | 3.1 | 1 |
| TAJC475*035#NJ | C | 4.7 | 35 | 1.6 | 6 | 2.2 | 1 |
| TAJD475*035#NJ | D | 4.7 | 35 | 1.6 | 6 | 1.5 | 1 |
| TAJC685*035#NJ | C | 6.8 | 35 | 2.4 | 6 | 1.8 | 1 |
| TAJD685*035#NJ | D | 6.8 | 35 | 2.4 | 6 | 1.3 | 1 |
| TAJC106*035#NJ | C | 10 | 35 | 3.5 | 6 | 1.6 | 1 |
| TAJD106*035#NJ | D | 10 | 35 | 3.5 | 6 | 1 | 1 |
| TAJE106*035#NJ | E | 10 | 35 | 3.5 | 6 | 0.9 | 1 ¹⁾ |
| TAJC156*035#NJ | C | 15 | 35 | 5.3 | 6 | 1.4 | 1 |
| TAJD156*035#NJ | D | 15 | 35 | 5.3 | 6 | 0.9 | 1 |
| TAJD226*035#NJ | D | 22 | 35 | 7.7 | 6 | 0.9 | 1 |
| TAJE226*035#NJ | E | 22 | 35 | 7.7 | 6 | 0.5 | 1 ¹⁾ |
| TAJD336*035#NJ | D | 33 | 35 | 11.6 | 6 | 0.9 | 1 |
| TAJE336*035#NJ | E | 33 | 35 | 11.6 | 6 | 0.9 | 1 ¹⁾ |
| TAJV336*035#NJ | V | 33 | 35 | 11.6 | 6 | 0.5 | 1 ¹⁾ |
| TAJE476*035#NJ | E | 47 | 35 | 16.5 | 6 | 0.9 | 1 ¹⁾ |
| TAJV476*035#NJ | V | 47 | 35 | 16.5 | 6 | 0.4 | 1 ¹⁾ |
| TAJV686*035#NJ | V | 68 | 35 | 23.8 | 6 | 0.5 | 1 ¹⁾ |

¹⁾ Dry pack option (see How to order) recommended for reduction of stress during soldering. Dry pack parts should be treated as MSL 3.

Moisture Sensitivity Level (MSL) is defined according to J-STD-020.

For AEC-Q200 availability, please contact AVX.

All technical data relates to an ambient temperature of +25°C. Capacitance and DF are measured at 120Hz, 0.5V RMS with a maximum DC bias of 2.2 volts. DCL is measured at rated voltage after 5 minutes.

For typical weight and composition see page 144.

NOTE: AVX reserves the right to supply a higher voltage rating or tighter tolerance part in the same case size, to the same reliability standards.

TAJ Series



Standard Tantalum

RATINGS & PART NUMBER REFERENCE

| AVX Part No. | Case Size | Cap (µF) | Rated Voltage (V) | DCL (µA) Max. | DF % Max. | ESR Max. (Ω) @100kHz | MSL |
|---|-----------|----------|-------------------|---------------|-----------|----------------------|-----------------|
| 50 Volt @ 85°C (33 Volt @ 125°C) | | | | | | | |
| TAJA104*050#NJ | A | 0.1 | 50 | 0.5 | 4 | 22 | 1 |
| TAJA154*050#NJ | A | 0.15 | 50 | 0.5 | 4 | 15 | 1 |
| TAJB154*050#NJ | B | 0.15 | 50 | 0.5 | 4 | 17 | 1 |
| TAJA224*050#NJ | A | 0.22 | 50 | 0.5 | 4 | 18 | 1 |
| TAJB224*050#NJ | B | 0.22 | 50 | 0.5 | 4 | 14 | 1 |
| TAJA334*050#NJ | A | 0.33 | 50 | 0.5 | 4 | 17 | 1 |
| TAJB334*050#NJ | B | 0.33 | 50 | 0.5 | 4 | 12 | 1 |
| TAJA474*050#NJ | A | 0.47 | 50 | 0.5 | 4 | 9.5 | 1 |
| TAJB474*050#NJ | B | 0.47 | 50 | 0.7 | 4 | 9.5 | 1 |
| TAJC474*050#NJ | C | 0.47 | 50 | 0.5 | 4 | 8 | 1 |
| TAJA684*050#NJ | A | 0.68 | 50 | 0.5 | 4 | 7.9 | 1 |
| TAJB684*050#NJ | B | 0.68 | 50 | 0.5 | 4 | 8 | 1 |
| TAJC684*050#NJ | C | 0.68 | 50 | 0.5 | 4 | 7 | 1 |
| TAJA105M050#NJ | A | 1 | 50 | 0.5 | 4 | 6.6 | 1 |
| TAJB105*050#NJ | B | 1 | 50 | 0.5 | 6 | 7 | 1 |
| TAJC105*050#NJ | C | 1 | 50 | 0.5 | 4 | 5.5 | 1 |
| TAJB155*050#NJ | B | 1.5 | 50 | 0.8 | 8 | 5.4 | 1 |
| TAJC155*050#NJ | C | 1.5 | 50 | 0.8 | 6 | 4.5 | 1 |
| TAJD155*050#NJ | D | 1.5 | 50 | 0.8 | 6 | 4 | 1 |
| TAJB225*050#NJ | B | 2.2 | 50 | 1.1 | 8 | 4.5 | 1 |
| TAJC225*050#NJ | C | 2.2 | 50 | 1.1 | 8 | 2.5 | 1 |
| TAJD225*050#NJ | D | 2.2 | 50 | 1.1 | 6 | 2.5 | 1 |
| TAJC335*050#NJ | C | 3.3 | 50 | 1.6 | 6 | 2.5 | 1 |
| TAJD335*050#NJ | D | 3.3 | 50 | 1.7 | 6 | 2 | 1 |
| TAJC475*050#NJ | C | 4.7 | 50 | 0.5 | 4 | 1.4 | 1 |
| TAJD475*050#NJ | D | 4.7 | 50 | 2.4 | 6 | 1.4 | 1 |
| TAJC685*050#NJ | C | 6.8 | 50 | 3.4 | 6 | 1 | 1 |
| TAJD685*050#NJ | D | 6.8 | 50 | 3.4 | 6 | 1 | 1 |
| TAJD106*050#NJ | D | 10 | 50 | 5 | 6 | 0.8 | 1 |
| TAJE106*050#NJ | E | 10 | 50 | 5 | 6 | 1 | 1 ¹⁾ |
| TAJV106*050#NJ | V | 10 | 50 | 5 | 6 | 0.65 | 1 ¹⁾ |
| TAJD156*050#NJ | D | 15 | 50 | 7.5 | 6 | 0.6 | 1 |
| TAJE156*050#NJ | E | 15 | 50 | 7.5 | 6 | 0.6 | 1 ¹⁾ |
| TAJV156*050#NJ | V | 15 | 50 | 7.5 | 6 | 0.6 | 1 ¹⁾ |
| TAJV226*050#NJ | V | 22 | 50 | 11 | 8 | 0.6 | 1 ¹⁾ |

¹⁾ Dry pack option (see How to order) recommended for reduction of stress during soldering. Dry pack parts should be treated as MSL 3.

For AEC-Q200 availability, please contact AVX.

Moisture Sensitivity Level (MSL) is defined according to J-STD-020.

All technical data relates to an ambient temperature of +25°C. Capacitance and DF are measured at 120Hz, 0.5V RMS with a maximum DC bias of 2.2 volts. DCL is measured at rated voltage after 5 minutes.

For typical weight and composition see page 144.

NOTE: AVX reserves the right to supply a higher voltage rating or tighter tolerance part in the same case size, to the same reliability standards.

TAJ Automotive Range



Standard Tantalum - Automotive Product Range

TAJ AUTOMOTIVE RANGE CAPACITANCE AND RATED VOLTAGE, V_R (VOLTAGE CODE) RANGE (LETTER DENOTES CASE SIZE)

| Capacitance | | Rated voltage DC (V_R) to 85°C | | | | | | |
|---------------|------|------------------------------------|---------|---------|---------|---------|---------|---------|
| μF | Code | 6.3V (J) | 10V (A) | 16V (C) | 20V (D) | 25V (E) | 35V (V) | 50V (T) |
| 0.10 | 104 | | | | | | | |
| 0.15 | 154 | | | | | | | A |
| 0.22 | 224 | | | | | | | |
| 0.33 | 334 | | | | | | A | A |
| 0.47 | 474 | | | | | A | A | A/B |
| 0.68 | 684 | | | | | A | A | B |
| 1.0 | 105 | | | A | A | A | A/B | B/C |
| 1.5 | 155 | | | | A | A | A/B | C |
| 2.2 | 225 | | A | A | A/B | A/B | B/C | C/D |
| 3.3 | 335 | A | | A/B | A/B | B | B/C | C/D |
| 4.7 | 475 | | A/B | A/B | A/B | B/C | B/C/D | C/D |
| 6.8 | 685 | | A/B | A/B | B/C | B/C | C/D | D |
| 10 | 106 | A/B | A/B | A/B/C | B/C | C/D | C/D | D/E |
| 15 | 156 | A | A/B/C | B/C | B/C | C/D | D | E |
| 22 | 226 | A/B/C | A/B/C | B/C/D | C/D | C/D | D/E | |
| 33 | 336 | A/B | B/C | C/D | C/D | D | E | |
| 47 | 476 | B/C | B/C/D | C/D | D | D/E | | |
| 68 | 686 | B/C | C/D | C/D | D/E | | | |
| 100 | 107 | C/D | C/D | D/E | E | | | |
| 150 | 157 | C/D | D/E | E | | | | |
| 220 | 227 | D | D/E | | | | | |
| 330 | 337 | D/E | E | | | | | |
| 470 | 477 | D/E | | | | | | |
| 680 | 687 | E | | | | | | |

Not recommended for new designs, higher voltage or smaller case size substitution are offered.

Released codes

Engineering samples - please contact manufacturer

Note: Voltage ratings are minimum values. AVX reserves the right to supply higher ratings in the same case size, to the same reliability standards.

HOW TO ORDER

| | | | | | | | |
|-------------|------------------|--|----------------------------------|--|---|-----------------------------|----------------------------|
| TAJ | C | 106 | M | 035 | T | NJ | V |
| Type | Case Size | Capacitance Code | Tolerance | Rated DC Voltage | Packaging | Specification Suffix | Dry Pack Option |
| | See table above | pF code: 1st two digits represent significant figures, 3rd digit represents multiplier (number of zeros to follow) | K = $\pm 10\%$ M = $\pm 20\%$ | 006 = 6.3Vdc 010 = 10Vdc 016 = 16Vdc 020 = 20Vdc 025 = 25Vdc 035 = 35Vdc 050 = 50Vdc | T = Automotive Lead Free 7" Reel U = Automotive Lead Free 13" Reel | NJ = Std Suffix | (D,E case sizes mandatory) |

TECHNICAL SPECIFICATIONS

Technical Data:

All technical data relate to an ambient temperature of +25°C

Capacitance Range: 0.22 μF to 680 μF

Capacitance Tolerance: $\pm 10\%$; $\pm 20\%$

| Rated Voltage (V_R) | $\leq +85^\circ\text{C}$: | 6.3 | 10 | 16 | 20 | 25 | 35 | 50 |
|----------------------------|-----------------------------|-----|----|----|----|----|----|----|
| Category Voltage (V_C) | $\leq +125^\circ\text{C}$: | 4 | 7 | 10 | 13 | 17 | 23 | 33 |
| Surge Voltage (V_S) | $\leq +85^\circ\text{C}$: | 8 | 13 | 20 | 26 | 32 | 46 | 65 |
| Surge Voltage (V_S) | $\leq +125^\circ\text{C}$: | 5 | 8 | 13 | 16 | 20 | 28 | 40 |

Temperature Range: -55°C to +125°C

Environmental Classification: 55/125/56 (IEC 68-2)

Reliability: 1% per 1000 hours at 85°C, V_R with 0.1 Ω /V series impedance, 60% confidence level

Termination Finished: Sn Plating (standard), Gold and SnPb Plating upon request

Meets requirements of AEC-Q200



TAJ Automotive Range



Standard Tantalum - Automotive Product Range

RATINGS & PART NUMBER REFERENCE

| AVX Part No.* | Case Size | Cap (µF) | Rated Voltage (V) | DCL (µA) Max. | DF % Max. | ESR Max. (Ω) @100kHz | MSL |
|---|-----------|----------|-------------------|---------------|-----------|----------------------|-----|
| 6.3 Volt @ 85°C (4 Volt @ 125°C) | | | | | | | |
| TAJA335*006TNJ | A | 3.3 | 6.3 | 0.5 | 6 | 7 | 1 |
| TAJA106*006TNJ | A | 10 | 6.3 | 0.6 | 6 | 4 | 1 |
| TAJB106*006TNJ | B | 10 | 6.3 | 0.6 | 6 | 3 | 1 |
| TAJA156*006TNJ | A | 15 | 6.3 | 0.9 | 6 | 3.5 | 1 |
| TAJA226*006TNJ | A | 22 | 6.3 | 1.4 | 6 | 3 | 1 |
| TAJB226*006TNJ | B | 22 | 6.3 | 1.4 | 6 | 2.5 | 1 |
| TAJC226*006TNJ | C | 22 | 6.3 | 1.4 | 6 | 2 | 1 |
| TAJA336*006TNJ | A | 33 | 6.3 | 2.1 | 8 | 2.2 | 1 |
| TAJB336*006TNJ | B | 33 | 6.3 | 2.1 | 6 | 2.2 | 1 |
| TAJB476*006TNJ | B | 47 | 6.3 | 3 | 6 | 2 | 1 |
| TAJC476*006TNJ | C | 47 | 6.3 | 3 | 6 | 1.6 | 1 |
| TAJB686*006TNJ | B | 68 | 6.3 | 4 | 8 | 0.9 | 1 |
| TAJC686*006TNJ | C | 68 | 6.3 | 4.3 | 6 | 1.5 | 1 |
| TAJC107*006TNJ | C | 100 | 6.3 | 6.3 | 6 | 0.9 | 1 |
| TAJD107*006TNJV | D | 100 | 6.3 | 6.3 | 6 | 0.9 | 3 |
| TAJC157*006TNJ | C | 150 | 6.3 | 9.5 | 6 | 1.3 | 1 |
| TAJD157*006TNJV | D | 150 | 6.3 | 9.5 | 6 | 0.9 | 3 |
| TAJD227*006TNJV | D | 220 | 6.3 | 13.9 | 8 | 0.4 | 3 |
| TAJD337*006TNJV | D | 330 | 6.3 | 20.8 | 8 | 0.4 | 3 |
| TAJE337*006TNJV | E | 330 | 6.3 | 20.8 | 8 | 0.4 | 3 |
| TAJD477*006TNJV | D | 470 | 6.3 | 28 | 12 | 0.4 | 3 |
| TAJE477*006TNJV | E | 470 | 6.3 | 28 | 10 | 0.4 | 3 |
| TAJE687*006TNJV | E | 680 | 6.3 | 42.8 | 10 | 0.5 | 3 |
| 10 Volt @ 85°C (7 Volt @ 125°C) | | | | | | | |
| TAJA225*010TNJ | A | 2.2 | 10 | 0.5 | 6 | 7 | 1 |
| TAJA475*010TNJ | A | 4.7 | 10 | 0.5 | 6 | 5 | 1 |
| TAJB475*010TNJ | B | 4.7 | 10 | 0.5 | 6 | 4 | 1 |
| TAJA685*010TNJ | A | 6.8 | 10 | 0.7 | 6 | 4 | 1 |
| TAJB685*010TNJ | B | 6.8 | 10 | 0.7 | 6 | 3 | 1 |
| TAJA106*010TNJ | A | 10 | 10 | 1 | 6 | 3 | 1 |
| TAJB106*010TNJ | B | 10 | 10 | 1 | 6 | 2.1 | 1 |
| TAJA156*010TNJ | A | 15 | 10 | 1.5 | 6 | 3.2 | 1 |
| TAJB156*010TNJ | B | 15 | 10 | 1.5 | 6 | 2.8 | 1 |
| TAJC156*010TNJ | C | 15 | 10 | 1.5 | 6 | 2 | 1 |
| TAJA226*010TNJ | A | 22 | 10 | 2.2 | 8 | 3 | 1 |
| TAJB226*010TNJ | B | 22 | 10 | 2.2 | 6 | 2.4 | 1 |
| TAJC226*010TNJ | C | 22 | 10 | 2.2 | 6 | 1.8 | 1 |
| TAJB336*010TNJ | B | 33 | 10 | 3.3 | 6 | 1.8 | 1 |
| TAJC336*010TNJ | C | 33 | 10 | 3.3 | 6 | 1.6 | 1 |
| TAJB476*010TNJ | B | 47 | 10 | 4.7 | 8 | 1 | 1 |
| TAJC476*010TNJ | C | 47 | 10 | 4.7 | 6 | 1.2 | 1 |
| TAJD476*010TNJV | D | 47 | 10 | 4.7 | 6 | 0.4 | 3 |
| TAJC686*010TNJ | C | 68 | 10 | 6.8 | 6 | 1.3 | 1 |
| TAJD686*010TNJV | D | 68 | 10 | 6.8 | 6 | 0.9 | 3 |
| TAJC107*010TNJ | C | 100 | 10 | 10 | 8 | 1.2 | 1 |
| TAJD107*010TNJV | D | 100 | 10 | 10 | 6 | 0.9 | 3 |
| TAJD157*010TNJV | D | 150 | 10 | 15 | 8 | 0.9 | 3 |
| TAJE157*010TNJV | E | 150 | 10 | 15 | 8 | 0.9 | 3 |
| TAJD227*010TNJV | D | 220 | 10 | 22 | 8 | 0.5 | 3 |
| TAJE227*010TNJV | E | 220 | 10 | 22 | 8 | 0.5 | 3 |
| TAJE337*010TNJV | E | 330 | 10 | 33 | 8 | 0.9 | 3 |
| 16 Volt @ 85°C (10 Volt @ 125°C) | | | | | | | |
| TAJA105*016TNJ | A | 1 | 16 | 0.5 | 4 | 11 | 1 |
| TAJA225*016TNJ | A | 2.2 | 16 | 0.5 | 6 | 6.5 | 1 |
| TAJA335*016TNJ | A | 3.3 | 16 | 0.5 | 6 | 5 | 1 |
| TAJB335*016TNJ | B | 3.3 | 16 | 0.5 | 6 | 4.5 | 1 |
| TAJA475*016TNJ | A | 4.7 | 16 | 0.8 | 6 | 4 | 1 |
| TAJB475*016TNJ | B | 4.7 | 16 | 0.8 | 6 | 3.5 | 1 |

| AVX Part No.* | Case Size | Cap (µF) | Rated Voltage (V) | DCL (µA) Max. | DF % Max. | ESR Max. (Ω) @100kHz | MSL |
|---|-----------|----------|-------------------|---------------|-----------|----------------------|-----|
| TAJA685*016TNJ | A | 6.8 | 16 | 1.1 | 6 | 3.5 | 1 |
| TAJB685*016TNJ | B | 6.8 | 16 | 1.1 | 6 | 2.5 | 1 |
| TAJA106*016TNJ | A | 10 | 16 | 1.6 | 6 | 3 | 1 |
| TAJB106*016TNJ | B | 10 | 16 | 1.6 | 6 | 2.8 | 1 |
| TAJC106*016TNJ | C | 10 | 16 | 1.6 | 6 | 2 | 1 |
| TAJB156*016TNJ | B | 15 | 16 | 2.4 | 6 | 2.5 | 1 |
| TAJC156*016TNJ | C | 15 | 16 | 2.4 | 6 | 1.8 | 1 |
| TAJB226*016TNJ | B | 22 | 16 | 3.5 | 6 | 2.3 | 1 |
| TAJC226*016TNJ | C | 22 | 16 | 3.5 | 6 | 1 | 1 |
| TAJD226*016TNJV | D | 22 | 16 | 3.5 | 6 | 1.1 | 3 |
| TAJC336*016TNJ | C | 33 | 16 | 5.3 | 6 | 1.5 | 1 |
| TAJD336*016TNJV | D | 33 | 16 | 5.3 | 6 | 0.9 | 3 |
| TAJC476*016TNJ | C | 47 | 16 | 7.5 | 6 | 0.5 | 1 |
| TAJD476*016TNJV | D | 47 | 16 | 7.5 | 6 | 0.9 | 3 |
| TAJC686*016TNJ | C | 68 | 16 | 10.9 | 6 | 1.3 | 1 |
| TAJD686*016TNJV | D | 68 | 16 | 10.9 | 6 | 0.9 | 3 |
| TAJD107*016TNJV | D | 100 | 16 | 16 | 6 | 0.6 | 3 |
| TAJE107*016TNJV | E | 100 | 16 | 16 | 6 | 0.9 | 3 |
| TAJE157*016TNJV | E | 150 | 16 | 23 | 8 | 0.3 | 3 |
| 20 Volt @ 85°C (13 Volt @ 125°C) | | | | | | | |
| TAJA105*020TNJ | A | 1 | 20 | 0.5 | 4 | 9 | 1 |
| TAJA155*020TNJ | A | 1.5 | 20 | 0.5 | 6 | 6.5 | 1 |
| TAJA225*020TNJ | A | 2.2 | 20 | 0.5 | 6 | 5.3 | 1 |
| TAJB225*020TNJ | B | 2.2 | 20 | 0.5 | 6 | 3.5 | 1 |
| TAJA335*020TNJ | A | 3.3 | 20 | 0.7 | 6 | 4.5 | 1 |
| TAJB335*020TNJ | B | 3.3 | 20 | 0.7 | 6 | 3 | 1 |
| TAJA475*020TNJ | A | 4.7 | 20 | 0.9 | 6 | 4 | 1 |
| TAJB475*020TNJ | B | 4.7 | 20 | 0.9 | 6 | 3 | 1 |
| TAJB685*020TNJ | B | 6.8 | 20 | 1.4 | 6 | 2.5 | 1 |
| TAJC685*020TNJ | C | 6.8 | 20 | 1.4 | 6 | 2 | 1 |
| TAJB106*020TNJ | B | 10 | 20 | 2 | 6 | 2.1 | 1 |
| TAJC106*020TNJ | C | 10 | 20 | 2 | 6 | 1.2 | 1 |
| TAJB156*020TNJ | B | 15 | 20 | 3 | 6 | 2 | 1 |
| TAJC156*020TNJ | C | 15 | 20 | 3 | 6 | 1.7 | 1 |
| TAJC226*020TNJ | C | 22 | 20 | 4.4 | 6 | 1.6 | 1 |
| TAJD226*020TNJV | D | 22 | 20 | 4.4 | 6 | 0.9 | 3 |
| TAJC336*020TNJ | C | 33 | 20 | 6.6 | 6 | 1.5 | 1 |
| TAJD336*020TNJV | D | 33 | 20 | 6.6 | 6 | 0.9 | 3 |
| TAJD476*020TNJV | D | 47 | 20 | 9.4 | 6 | 0.9 | 3 |
| TAJD686*020TNJV | D | 68 | 20 | 13.6 | 6 | 0.4 | 3 |
| TAJE686*020TNJV | E | 68 | 20 | 13.6 | 6 | 0.9 | 3 |
| TAJE107*020TNJV | E | 100 | 20 | 20 | 6 | 0.4 | 3 |
| 25 Volt @ 85°C (17 Volt @ 125°C) | | | | | | | |
| TAJA474*025TNJ | A | 0.47 | 25 | 0.5 | 4 | 14 | 1 |
| TAJA684*025TNJ | A | 0.68 | 25 | 0.5 | 4 | 10 | 1 |
| TAJA105*025TNJ | A | 1 | 25 | 0.5 | 4 | 8 | 1 |
| TAJA155*025TNJ | A | 1.5 | 25 | 0.5 | 6 | 7.5 | 1 |
| TAJA225*025TNJ | A | 2.2 | 25 | 0.6 | 6 | 7 | 1 |
| TAJB225*025TNJ | B | 2.2 | 25 | 0.6 | 6 | 4.5 | 1 |
| TAJB335*025TNJ | B | 3.3 | 25 | 0.8 | 6 | 3.5 | 1 |
| TAJB475*025TNJ | B | 4.7 | 25 | 1.2 | 6 | 1.5 | 1 |
| TAJC475*025TNJ | C | 4.7 | 25 | 1.2 | 6 | 2.4 | 1 |
| TAJB685*025TNJ | B | 6.8 | 25 | 1.7 | 6 | 2.8 | 1 |
| TAJC685*025TNJ | C | 6.8 | 25 | 1.7 | 6 | 2 | 1 |
| TAJC106*025TNJ | C | 10 | 25 | 2.5 | 6 | 1.8 | 1 |
| TAJD106*025TNJV | D | 10 | 25 | 2.5 | 6 | 1.2 | 3 |
| TAJC156*025TNJ | C | 15 | 25 | 3.8 | 6 | 1.6 | 1 |
| TAJD156*025TNJV | D | 15 | 25 | 3.8 | 6 | 1 | 3 |
| TAJC226*025TNJ | C | 22 | 25 | 5.5 | 6 | 1.4 | 1 |

Moisture Sensitivity Level (MSL) is defined according to J-STD-020

*Please use "U" instead of "T" in the suffix letter for 13" reel packaging

Please use specific PN for automotive version – see "HOW TO ORDER".

All technical data relates to an ambient temperature of +25°C. Capacitance and DF are measured at 120Hz, 0.5V RMS with a maximum DC bias of 2.2 volts.

DCL is measured at rated voltage after 5 minutes.

For typical weight and composition see page 144.

NOTE: AVX reserves the right to supply a higher voltage rating or tighter tolerance part in the same case size, to the same reliability standards.

TAJ Automotive Range



Standard Tantalum - Automotive Product Range

RATINGS & PART NUMBER REFERENCE

| AVX Part No.* | Case Size | Cap (µF) | Rated Voltage (V) | DCL (µA) Max. | DF % Max. | ESR Max. (Ω) @100kHz | MSL |
|---|-----------|----------|-------------------|---------------|-----------|----------------------|-----|
| TAJD226*025TNJV | D | 22 | 25 | 5.5 | 6 | 0.9 | 3 |
| TAJD336*025TNJV | D | 33 | 25 | 8.3 | 6 | 0.9 | 3 |
| TAJD476*025TNJV | D | 47 | 25 | 11.8 | 6 | 0.9 | 3 |
| TAJE476*025TNJV | E | 47 | 25 | 11.8 | 6 | 0.9 | 3 |
| 35 Volt @ 85°C (23 Volt @ 125°C) | | | | | | | |
| TAJA334*035TNJ | A | 0.33 | 35 | 0.5 | 4 | 15 | 1 |
| TAJA474*035TNJ | A | 0.47 | 35 | 0.5 | 4 | 12 | 1 |
| TAJA684*035TNJ | A | 0.68 | 35 | 0.5 | 4 | 8 | 1 |
| TAJA105*035TNJ | A | 1 | 35 | 0.5 | 4 | 7.5 | 1 |
| TAJB105*035TNJ | B | 1 | 35 | 0.5 | 4 | 6.5 | 1 |
| TAJA155*035TNJ | A | 1.5 | 35 | 0.5 | 6 | 7.5 | 1 |
| TAJB155*035TNJ | B | 1.5 | 35 | 0.5 | 6 | 5.2 | 1 |
| TAJB225*035TNJ | B | 2.2 | 35 | 0.8 | 6 | 4.2 | 1 |
| TAJC225*035TNJ | C | 2.2 | 35 | 0.8 | 6 | 3.5 | 1 |
| TAJB335*035TNJ | B | 3.3 | 35 | 1.2 | 6 | 3.5 | 1 |
| TAJC335*035TNJ | C | 3.3 | 35 | 1.2 | 6 | 2.5 | 1 |
| TAJB475*035TNJ | B | 4.7 | 35 | 1.6 | 6 | 3.1 | 1 |
| TAJC475*035TNJ | C | 4.7 | 35 | 1.6 | 6 | 2.2 | 1 |
| TAJD475*035TNJV | D | 4.7 | 35 | 1.6 | 6 | 1.5 | 3 |
| TAJC685*035TNJ | C | 6.8 | 35 | 2.4 | 6 | 1.8 | 1 |
| TAJD685*035TNJV | D | 6.8 | 35 | 2.4 | 6 | 1.3 | 3 |
| TAJC106*035TNJ | C | 10 | 35 | 3.5 | 6 | 1.6 | 1 |
| TAJD106*035TNJV | D | 10 | 35 | 3.5 | 6 | 1 | 3 |
| TAJD156*035TNJV | D | 15 | 35 | 5.3 | 6 | 0.9 | 3 |
| TAJD226*035TNJV | D | 22 | 35 | 7.7 | 6 | 0.9 | 3 |
| TAJE226*035TNJV | E | 22 | 35 | 7.7 | 6 | 0.5 | 3 |
| TAJE336*035TNJV | E | 33 | 35 | 11.6 | 6 | 0.9 | 3 |
| 50 Volt @ 85°C (33 Volt @ 125°C) | | | | | | | |
| TAJA224*050TNJ | A | 0.22 | 50 | 0.5 | 4 | 18 | 1 |
| TAJA334*050TNJ | A | 0.33 | 50 | 0.5 | 4 | 17 | 1 |
| TAJA474*050TNJ | A | 0.47 | 50 | 0.5 | 4 | 9.5 | 1 |
| TAJB474*050TNJ | B | 0.47 | 50 | 0.7 | 4 | 9.5 | 1 |
| TAJB684*050TNJ | B | 0.68 | 50 | 0.5 | 4 | 8 | 1 |
| TAJB105*050TNJ | B | 1 | 50 | 0.5 | 6 | 7 | 1 |
| TAJC105*050TNJ | C | 1 | 50 | 0.5 | 4 | 5.5 | 1 |
| TAJC155*050TNJ | C | 1.5 | 50 | 0.8 | 6 | 4.5 | 1 |
| TAJC225*050TNJ | C | 2.2 | 50 | 1.1 | 8 | 2.5 | 1 |
| TAJD225*050TNJV | D | 2.2 | 50 | 1.1 | 6 | 2.5 | 3 |
| TAJC335*050TNJ | C | 3.3 | 50 | 1.6 | 6 | 2.5 | 1 |
| TAJD335*050TNJV | D | 3.3 | 50 | 1.7 | 6 | 2 | 3 |
| TAJC475*050TNJ | C | 4.7 | 50 | 0.5 | 4 | 1.4 | 1 |
| TAJD475*050TNJV | D | 4.7 | 50 | 2.4 | 6 | 1.4 | 3 |
| TAJD685*050TNJV | D | 6.8 | 50 | 3.4 | 6 | 1 | 3 |
| TAJD106*050TNJV | D | 10 | 50 | 5 | 6 | 0.8 | 3 |
| TAJE106*050TNJV | E | 10 | 50 | 5 | 6 | 1 | 3 |
| TAJE156*050TNJV | E | 15 | 50 | 7.5 | 6 | 0.6 | 3 |

Moisture Sensitivity Level (MSL) is defined according to J-STD-020

*Please use "U" instead of "T" in the suffix letter for 13" reel packaging

Please use specific PN for automotive version – see "HOW TO ORDER".

All technical data relates to an ambient temperature of +25°C. Capacitance and DF are measured at 120Hz, 0.5V RMS with a maximum DC bias of 2.2 volts.

DCL is measured at rated voltage after 5 minutes.

For typical weight and composition see page 144.

NOTE: AVX reserves the right to supply a higher voltage rating or tighter tolerance part in the same case size, to the same reliability standards.

F93 Series



Resin-Molded Chip, Standard Tantalum J-Lead



For SMD

- Compliant to the RoHS directive (2002/95/EC).

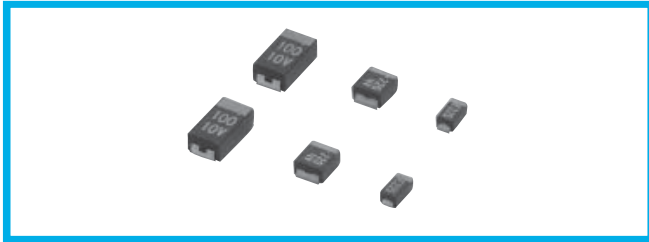

Type numbering system (Example: 10V 10μF)

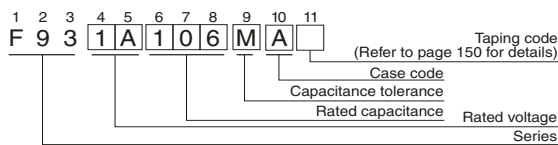

Drawing

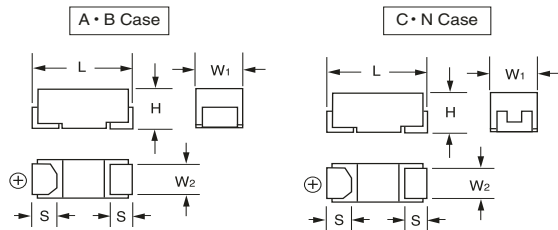

Dimensions

| Case code | L | W ₁ | W ₂ | H | S |
|-----------|-----------|----------------|----------------|-----------|-----------|
| A | 3.2 ± 0.2 | 1.6 ± 0.2 | 1.2 ± 0.1 | 1.6 ± 0.2 | 0.8 ± 0.2 |
| B | 3.5 ± 0.2 | 2.8 ± 0.2 | 2.2 ± 0.1 | 1.9 ± 0.2 | 0.8 ± 0.2 |
| C | 6.0 ± 0.2 | 3.2 ± 0.2 | 2.2 ± 0.1 | 2.5 ± 0.2 | 1.3 ± 0.2 |
| N | 7.3 ± 0.2 | 4.3 ± 0.2 | 2.4 ± 0.1 | 2.8 ± 0.2 | 1.3 ± 0.2 |

Marking

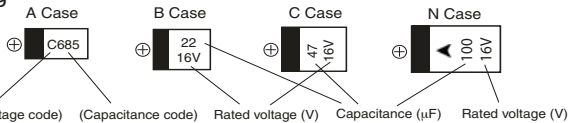

| | | | |
|------|---|-----|---|
| 4V | G | 20V | D |
| 6.3V | J | 25V | E |
| 10V | A | 35V | V |
| 16V | C | | |

Standard Ratings

| Cap. (μF) | Code | V | | | | | | | |
|-----------|------|-------------|-----------|-----------|-------------|-------|-------|-------|--|
| | | 4 | 6.3 | 10 | 16 | 20 | 25 | 35 | |
| 0.68 | 684 | OG | OJ | 1A | 1C | 1D | 1E | 1V | |
| 1 | 105 | | | | A | | A | A | |
| 1.5 | 155 | | | | | | A | A | |
| 2.2 | 225 | | | | A | A | A | A · B | |
| 3.3 | 335 | | | | A | A | A | B | |
| 4.7 | 475 | | | | A | A · B | A · B | B · C | |
| 6.8 | 685 | | | A | A | A · B | A · B | C | |
| 10 | 106 | | A | A | A · B | A · B | B · C | C | |
| 15 | 156 | | A | A | A · B | A · B | C | N | |
| 22 | 226 | A | A | A · B | A · B · C | B · C | C · N | N | |
| 33 | 336 | A | A | A · B | B · C | C · N | N | | |
| 47 | 476 | A | A · B | A · B · C | (B) · C · N | C · N | N | | |
| 68 | 686 | A | A · B | B · C | N | (N) | | | |
| 100 | 107 | A · B | A · B · C | B · C · N | C · N | | | | |
| 150 | 157 | B | B · C | C · N | N | | | | |
| 220 | 227 | (A) · B · C | B · C · N | N | N | | | | |
| 330 | 337 | C | N | N | | | | | |
| 470 | 477 | N | N | | | | | | |
| 680 | 687 | N | | | | | | | |

() The series in parentheses are being developed.

Please contact to your local AVX sales office when these series are being designed in your application.

Specifications

| Item | Performance Characteristics |
|-----------------------------------|---|
| Category | |
| Temperature Range | -55 to +125°C (Rated temperature : +85°C) |
| Capacitance Tolerance | ±20%, ±10% (at 120Hz) |
| Dissipation Factor (120Hz) | Refer to next page |
| ESR (100kHz) | Refer to next page |
| Leakage Current | <ul style="list-style-type: none"> After 1 minute's application of rated voltage, leakage current at 20°C is not more than 0.01CV or 0.5μA, whichever is greater. After 1 minute's application of rated voltage, leakage current at 85°C is not more than 0.1CV or 5μA, whichever is greater. After 1 minute's application of derated voltage, leakage current at 125°C is not more than 0.125CV or 6.3μA, whichever is greater. |
| Capacitance Change by Temperature | +15% Max. (at +125°C) +10% Max. (at +85°C) -10% Max. (at -55°C) |
| Damp Heat (Steady State) | At 40°C 90 to 95% R.H. 500 hours (No voltage applied) Capacitance Change...Refer to next page (* 1) Dissipation Factor...Initial specified value or less Leakage Current...Initial specified value or less |
| Temperature Cycles | -55°C / +125°C 30 minutes each 5 cycles Capacitance Change...Refer to next page (* 1) Dissipation Factor...Initial specified value or less Leakage Current...Initial specified value or less |
| Resistance to Soldering Heat | 10 seconds reflow at 260°C, 5 seconds immersion at 260°C Capacitance Change...Refer to next page (* 1) Dissipation Factor...Initial specified value or less Leakage Current...Initial specified value or less |
| Surge | After application of surge voltage in series with a 33Ω resistor at the rate of 30 seconds ON, 30 seconds OFF, for 1000 successive test cycles at 85°C, capacitors shall meet the characteristic requirements table below. Capacitance Change...Refer to next page (* 1) Dissipation Factor...Initial specified value or less Leakage Current...Initial specified value or less |
| Endurance | After 2000 hours' application of rated voltage in series with a 3Ω resistor at 85°C, or derated voltage in series with a 3Ω resistor at 125°C, capacitors shall meet the characteristic requirements table below. Capacitance Change...Refer to next page (* 1) Dissipation Factor...Initial specified value or less Leakage Current...Initial specified value or less |
| Shear Test | After applying the pressure load of 5N for 10±1 seconds horizontally to the center of capacitor side body which has no electrode and has been soldered beforehand on a substrate, there shall be found neither exfoliation nor its sign at the terminal electrode. For 10±1 seconds |
| Terminal Strength | Keeping a capacitor surface-mounted on a substrate upside down and supporting the substrate at both of the opposite bottom points 45mm apart from the center of capacitor, the pressure strength is applied with a specified jig at the center of substrate so that the substrate may bend by 1mm as illustrated. Then, there shall be found no remarkable abnormality on the capacitor terminals. 20 45 45 |
| Failure Rate | 1% per 1000 hours at 85°C, V _R with 0.1Ω/V series impedance, 60% confidence level. |

We can supply the type of compliance to AEC-Q200. Please contact to your local AVX sales office when these series are being designed in your application.



F93 Series



Resin-Molded Chip, Standard Tantalum J-Lead

■ Standard Ratings

| Rated Volt | Rated Capacitance (μF) | Case code | Part Number | Leakage Current (μA) | Dissipation Factor (%@120Hz) | ESR (Ω@100kHz) | *1 ΔC/C (%) |
|------------|------------------------|-------------|-------------|----------------------|------------------------------|----------------|-------------|
| 4V | 22 | A | F930G226MAA | 0.9 | 6 | 2.5 | * |
| | 33 | A | F930G336MAA | 1.3 | 8 | 2.5 | * |
| | 47 | A | F930G476MAA | 1.9 | 18 | 2.5 | * |
| | 68 | A | F930G686MAA | 2.7 | 24 | 2.5 | * |
| | 100 | A | F930G107MAA | 4.0 | 30 | 2.0 | * |
| | 100 | B | F930G107MBA | 4.0 | 14 | 0.9 | * |
| | 150 | B | F930G157MBA | 6.0 | 16 | 0.7 | * |
| | 220 | B | F930G227MBA | 8.8 | 18 | 0.7 | * |
| | 220 | C | F930G227MCC | 8.8 | 12 | 0.7 | * |
| | 330 | C | F930G337MCC | 13.2 | 14 | 0.7 | * |
| 470 | N | F930G477MNC | 18.8 | 16 | 0.3 | * | |
| 680 | N | F930G687MNC | 27.2 | 18 | 0.3 | * | |
| 6.3V | 10 | A | F930J106MAA | 0.6 | 6 | 3.0 | * |
| | 15 | A | F930J156MAA | 0.9 | 6 | 2.9 | * |
| | 22 | A | F930J226MAA | 1.4 | 8 | 2.5 | * |
| | 33 | A | F930J336MAA | 2.1 | 8 | 2.5 | * |
| | 47 | A | F930J476MAA | 3.0 | 18 | 2.5 | * |
| | 47 | B | F930J476MBA | 3.0 | 6 | 1.0 | * |
| | 68 | A | F930J686MAA | 4.3 | 20 | 2.0 | * |
| | 68 | B | F930J686MBA | 4.3 | 8 | 1.0 | * |
| | 100 | A | F930J107MAA | 6.3 | 35 | 2.0 | ±15 |
| | 100 | B | F930J107MBA | 6.3 | 14 | 0.9 | * |
| | 100 | C | F930J107MCC | 6.3 | 8 | 0.7 | * |
| | 150 | B | F930J157MBA | 9.5 | 18 | 0.9 | * |
| | 150 | C | F930J157MCC | 9.5 | 12 | 0.7 | * |
| | 220 | B | F930J227MBA | 13.9 | 30 | 1.2 | ±15 |
| | 220 | C | F930J227MCC | 13.9 | 14 | 0.7 | * |
| | 220 | N | F930J227MNC | 13.9 | 10 | 0.5 | * |
| 330 | N | F930J337MNC | 20.8 | 14 | 0.5 | * | |
| 470 | N | F930J477MNC | 29.6 | 16 | 0.3 | * | |
| 10V | 6.8 | A | F931A685MAA | 0.7 | 6 | 3.5 | * |
| | 10 | A | F931A106MAA | 1.0 | 6 | 3.0 | * |
| | 15 | A | F931A156MAA | 1.5 | 8 | 2.9 | * |
| | 22 | A | F931A226MAA | 2.2 | 12 | 2.5 | * |
| | 22 | B | F931A226MBA | 2.2 | 6 | 1.9 | * |
| | 33 | A | F931A336MAA | 3.3 | 18 | 2.5 | * |
| | 33 | B | F931A336MBA | 3.3 | 8 | 1.4 | * |
| | 47 | A | F931A476MAA | 4.7 | 40 | 2.0 | ±15 |
| | 47 | B | F931A476MBA | 4.7 | 8 | 1.0 | * |
| | 47 | C | F931A476MCC | 4.7 | 6 | 0.9 | * |
| | 68 | B | F931A686MBA | 6.8 | 12 | 0.9 | ±15 |
| | 68 | C | F931A686MCC | 6.8 | 8 | 0.8 | * |
| | 100 | B | F931A107MBA | 10.0 | 18 | 1.2 | ±15 |
| | 100 | C | F931A107MCC | 10.0 | 10 | 0.7 | * |
| | 100 | N | F931A107MNC | 10.0 | 8 | 0.6 | * |
| | 150 | C | F931A157MCC | 15.0 | 14 | 0.7 | * |
| | 150 | N | F931A157MNC | 15.0 | 10 | 0.6 | * |
| | 220 | N | F931A227MNC | 22.0 | 12 | 0.5 | * |
| | 330 | N | F931A337MNC | 33.0 | 18 | 0.5 | * |

1 : ΔC/C Marked ""

| Item | A·B·C·N Case (%) |
|---------------------------|------------------|
| Damp Heat | ±10 |
| Temperature cycles | ±5 |
| Resistance soldering heat | ±5 |
| Surge | ±5 |
| Endurance | ±10 |

| Rated Volt | Rated Capacitance (μF) | Case code | Part Number | Leakage Current (μA) | Dissipation Factor (%@120Hz) | ESR (Ω@100kHz) | *1 ΔC/C (%) |
|------------|------------------------|-------------|-------------|----------------------|------------------------------|----------------|-------------|
| 16V | 1 | A | F931C105MAA | 0.5 | 4 | 7.5 | * |
| | 2.2 | A | F931C225MAA | 0.5 | 4 | 5.0 | * |
| | 3.3 | A | F931C335MAA | 0.5 | 4 | 4.5 | * |
| | 4.7 | A | F931C475MAA | 0.8 | 6 | 4.0 | * |
| | 6.8 | A | F931C685MAA | 1.1 | 6 | 3.5 | * |
| | 10 | A | F931C106MAA | 1.6 | 6 | 3.0 | * |
| | 10 | B | F931C106MBA | 1.6 | 6 | 2.0 | * |
| | 15 | A | F931C156MAA | 2.4 | 10 | 3.0 | * |
| | 15 | B | F931C156MBA | 2.4 | 6 | 2.0 | * |
| | 22 | A | F931C226MAA | 3.5 | 15 | 3.0 | ±15 |
| | 22 | B | F931C226MBA | 3.5 | 8 | 1.9 | * |
| | 22 | C | F931C226MCC | 3.5 | 6 | 1.1 | * |
| | 33 | B | F931C336MBA | 5.3 | 8 | 1.9 | * |
| | 33 | C | F931C336MCC | 5.3 | 6 | 1.1 | * |
| | 47 | C | F931C476MCC | 7.5 | 8 | 0.9 | * |
| | 47 | N | F931C476MNC | 7.5 | 6 | 0.7 | * |
| | 68 | N | F931C686MNC | 10.9 | 6 | 0.6 | * |
| | 100 | C | F931C107MCC | 16.0 | 15 | 0.7 | ±10 |
| 100 | N | F931C107MNC | 16.0 | 10 | 0.6 | * | |
| 150 | N | F931C157MNC | 24.0 | 15 | 0.6 | * | |
| 220 | N | F931C227MNC | 35.2 | 25 | 0.7 | ±10 | |
| 20V | 2.2 | A | F931D225MAA | 0.5 | 4 | 5.0 | * |
| | 3.3 | A | F931D335MAA | 0.7 | 4 | 4.5 | * |
| | 4.7 | A | F931D475MAA | 0.9 | 6 | 3.0 | * |
| | 4.7 | B | F931D475MBA | 0.9 | 6 | 2.8 | * |
| | 6.8 | A | F931D685MAA | 1.4 | 6 | 3.5 | * |
| | 6.8 | B | F931D685MBA | 1.4 | 6 | 2.5 | * |
| | 10 | A | F931D106MAA | 2.0 | 8 | 3.5 | * |
| | 10 | B | F931D106MBA | 2.0 | 6 | 2.1 | * |
| | 15 | C | F931D156MCC | 3.0 | 6 | 1.2 | * |
| | 22 | B | F931D226MBA | 4.4 | 8 | 1.9 | * |
| | 22 | C | F931D226MCC | 4.4 | 8 | 1.1 | * |
| | 33 | C | F931D336MCC | 6.6 | 8 | 1.1 | * |
| 33 | N | F931D336MNC | 6.6 | 6 | 0.7 | * | |
| 47 | C | F931D476MCC | 9.4 | 10 | 1.1 | * | |
| 47 | N | F931D476MNC | 9.4 | 8 | 0.7 | * | |
| 25V | 1 | A | F931E105MAA | 0.5 | 4 | 7.5 | * |
| | 1.5 | A | F931E155MAA | 0.5 | 4 | 6.7 | * |
| | 2.2 | A | F931E225MAA | 0.6 | 6 | 6.3 | * |
| | 3.3 | A | F931E335MAA | 0.8 | 6 | 6.0 | * |
| | 4.7 | A | F931E475MAA | 1.2 | 8 | 4.0 | * |
| | 4.7 | B | F931E475MBA | 1.2 | 6 | 2.8 | * |
| | 10 | B | F931E106MBA | 2.5 | 12 | 1.9 | * |
| | 10 | C | F931E106MCC | 2.5 | 6 | 1.5 | * |
| | 15 | C | F931E156MCC | 3.8 | 8 | 1.2 | * |
| | 22 | C | F931E226MCC | 5.5 | 8 | 1.1 | * |
| | 22 | N | F931E226MNC | 5.5 | 6 | 0.7 | * |
| | 33 | N | F931E336MNC | 8.3 | 8 | 0.7 | * |
| 47 | N | F931E476MNC | 11.8 | 8 | 0.7 | * | |
| 35V | 0.68 | A | F931V684MAA | 0.5 | 4 | 7.6 | * |
| | 1 | A | F931V105MAA | 0.5 | 4 | 7.5 | * |
| | 1.5 | A | F931V155MAA | 0.5 | 6 | 7.5 | * |
| | 2.2 | A | F931V225MAA | 0.8 | 6 | 7.0 | * |
| | 2.2 | B | F931V225MBA | 0.8 | 4 | 3.8 | * |
| | 3.3 | B | F931V335MBA | 1.2 | 4 | 3.5 | * |
| | 4.7 | B | F931V475MBA | 1.6 | 8 | 3.1 | * |
| | 4.7 | C | F931V475MCC | 1.6 | 6 | 1.8 | * |
| | 6.8 | C | F931V685MCC | 2.4 | 6 | 1.8 | * |
| | 10 | C | F931V106MCC | 3.5 | 6 | 1.6 | * |
| | 15 | N | F931V156MNC | 5.3 | 6 | 0.7 | * |
| | 22 | N | F931V226MNC | 7.7 | 8 | 0.7 | * |

* In case of capacitance tolerance ±10% type, [K] will be put at 9th digit of type numbering system.



F93-AJ6 Series



Resin-Molded Chip - Automotive Product Range



- Compliant to the RoHS directive (2002/95/EC)
- Compliant to AEC-Q200

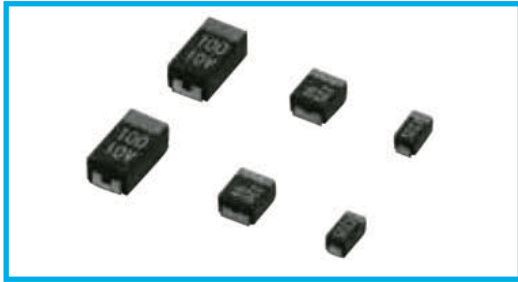

APPLICATIONS

- Cabin electronics
- Infotainment

HOW TO ORDER

(Example : 10V 10µF)

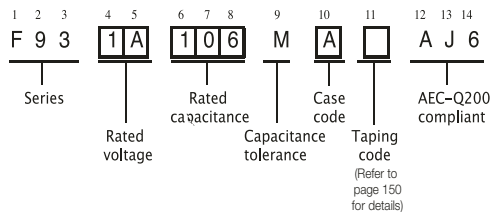

CASE DIMENSIONS

(mm)

| Case Code | L | W ₁ | W ₂ | H | S |
|-----------|-----------|----------------|----------------|-----------|-----------|
| A | 3.2 ± 0.2 | 1.6 ± 0.2 | 1.2 ± 0.1 | 1.6 ± 0.2 | 0.8 ± 0.2 |
| B | 3.5 ± 0.2 | 2.8 ± 0.2 | 2.2 ± 0.1 | 1.9 ± 0.2 | 0.8 ± 0.2 |
| C | 6.0 ± 0.2 | 3.2 ± 0.2 | 2.2 ± 0.1 | 2.5 ± 0.2 | 1.3 ± 0.2 |
| N | 7.3 ± 0.2 | 4.3 ± 0.2 | 2.4 ± 0.1 | 2.8 ± 0.2 | 1.3 ± 0.2 |

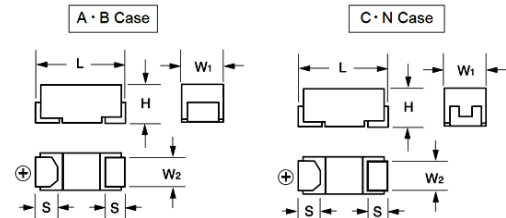

MARKING

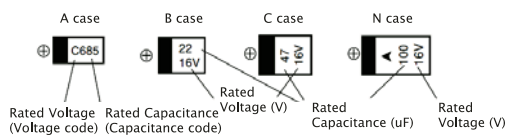

CAPACITANCE AND RATED VOLTAGE, VR (VOLTAGE CODE) RANGE (LETTER DENOTES CASE SIZE)

| Capacitance | | Rated Voltage | | | | | | |
|-------------|------|---------------|-----------|----------|----------|----------|----------|----------|
| (µF) | Code | 4V (0G) | 6.3V (0J) | 10V (1A) | 16V (1C) | 20V (1D) | 25V (1E) | 35V (1V) |
| 1 | 105 | | | | A | | A | A |
| 1.5 | 155 | | | | | | A | A |
| 2.2 | 225 | | | | A | A | A | A,B |
| 3.3 | 335 | | | | A | A | A | B |
| 4.7 | 475 | | | | A | A,B | A,B | B,C |
| 6.8 | 685 | | | A | A | A,B | | C |
| 10 | 106 | | A | A | A,B | A,B | B,C | C |
| 15 | 156 | | A | A | A,B | C | C | N |
| 22 | 226 | A | A | A,B | B,C | B,C | C,N | N |
| 33 | 336 | A | A | A,B | B,C | C,N | N | |
| 47 | 476 | A | A,B | B,C | C,N | C,N | N | |
| 68 | 686 | A | A,B | B,C | N | | | |
| 100 | 107 | A,B | B,C | C,N | N | | | |
| 150 | 157 | B | B,C | N | N | | | |
| 220 | 227 | B,C | C,N | N | | | | |
| 330 | 337 | C | N | N | | | | |
| 470 | 477 | N | N | | | | | |
| 680 | 687 | N | | | | | | |

SPECIFICATIONS

| ITEM | PERFORMANCE CHARACTERISTICS |
|-----------------------------------|---|
| Category Temperature Range | -55 to +125°C (Rated temperature : +85°C) |
| Capacitance Tolerance | ±20%, ±10% (at 120Hz) |
| Dissipation Factor | Refer to next page |
| ESR (100kHz) | Refer to next page |
| Leakage Current | <ul style="list-style-type: none"> After 1 minute's application of rated voltage, leakage current at 20°C is not more than 0.01CV or 0.5µA, whichever is greater. After 1 minute's application of rated voltage, leakage current at 85°C is not more than 0.1CV or 5µA, whichever is greater. After 1 minute's application of derated voltage, leakage current at 125°C is not more than 0.125CV or 6.3µA, whichever is greater. |
| Capacitance Change by Temperature | +15% Max. (at +125°C) +10% Max. (at +85°C) -10% Max. (at -55°C) |
| Damp Heat (Steady State) | At 40°C, 90 to 95% R.H. 500 hours (No voltage applied) Capacitance Change Refer to next page (*1) Dissipation Factor Initial specified value or less Leakage Current Initial specified value or less |
| Load Humidity | After 1000 hour's application of rated voltage in series with a 33Ω resistor at 85°C, 85% R.H., capacitors meet the characteristics requirements table below. Capacitance Change Refer to next page (*1) Dissipation Factor Initial specified value or less Leakage Current 125% or less than the initial specified value |
| Temperature Cycles | At -55°C / +125°C, For 30 minutes each, 1000 cycles Capacitance Change Refer to next page (*1) Dissipation Factor Initial specified value or less Leakage Current Initial specified value or less |
| Resistance to Soldering Heat | 10 seconds reflow at 260°C, 10 seconds immersion at 260°C. Capacitance Change Refer to next page (*1) Dissipation Factor Initial specified value or less Leakage Current Initial specified value or less |
| Surge | After application of surge in series with a 33Ω resistor at the rate of 30 seconds ON, 30 seconds OFF, for 1000 successive test cycles at 85°C, capacitors shall meet the characteristic requirements table below. Capacitance Change Refer to next page (*1) Dissipation Factor Initial specified value or less Leakage Current Initial specified value or less |
| Endurance | After 2000 hours' application of rated voltage in series with a 3Ω resistor at 85°C, or derated voltage in series with a 3Ω resistor at 125°C, capacitors shall meet the characteristic requirements table below. Capacitance Change Refer to next page (*1) Dissipation Factor Initial specified value or less Leakage Current Initial specified value or less |
| Shear Test | After applying the pressure load of 17.7N for 60 seconds horizontally to the center of capacitor side body which has no electrode and has been soldered beforehand on a substrate, there shall be found neither exfoliation nor its sign at the terminal electrode. |
| Terminal Strength | Keeping a capacitor surface-mounted on a substrate upside down and supporting the substrate at both of the opposite bottom points 45mm apart from the center of capacitor, the pressure strength is applied with a specified jig at the center of the substrate so that substrate may bend by 1mm as illustrated. Then, there shall be found no remarkable abnormality on the capacitor terminals. |
| Failure Rate | 1% per 1000 hours at 85°C, V _R with 0.1Ω/V series impedance, 60% confidence level. |



F93-AJ6 Series



Resin-Molded Chip - Automotive Product Range

RATINGS & PART NUMBER REFERENCE

| Rated Volt | Rated Capacitance (µF) | Case Code | Part Number | Leakage Current (µA) | Dissipation Factor (%@120Hz) | ESR (Ω@100kHz) | *1 ΔC/C (%) |
|------------|------------------------|----------------|----------------|----------------------|------------------------------|----------------|-------------|
| 4V | 22 | A | F930G226MAAAJ6 | 0.9 | 6 | 2.5 | * |
| | 33 | A | F930G336MAAAJ6 | 1.3 | 8 | 2.5 | * |
| | 47 | A | F930G476MAAAJ6 | 1.9 | 18 | 2.5 | * |
| | 68 | A | F930G686MAAAJ6 | 2.7 | 24 | 2.5 | * |
| | 100 | A | F930G107MAAAJ6 | 4 | 30 | 2 | * |
| | 100 | B | F930G107MBAAJ6 | 4 | 14 | 0.9 | * |
| | 150 | B | F930G157MBAAJ6 | 6 | 16 | 0.7 | * |
| | 220 | B | F930G227MBAAJ6 | 8.8 | 18 | 0.7 | * |
| | 220 | C | F930G227MCCAJ6 | 8.8 | 12 | 0.7 | * |
| | 330 | C | F930G337MCCAJ6 | 13.2 | 14 | 0.7 | * |
| 6.3V | 470 | N | F930G477MNCAJ6 | 18.8 | 16 | 0.3 | * |
| | 680 | N | F930G687MNCAJ6 | 27.2 | 18 | 0.3 | * |
| | 10 | A | F930J106MAAAJ6 | 0.6 | 6 | 3 | * |
| | 15 | A | F930J156MAAAJ6 | 0.9 | 6 | 2.9 | * |
| | 22 | A | F930J226MAAAJ6 | 1.4 | 8 | 2.5 | * |
| | 33 | A | F930J336MAAAJ6 | 2.1 | 8 | 2.5 | * |
| | 47 | A | F930J476MAAAJ6 | 3 | 18 | 2.5 | * |
| | 47 | B | F930J476MBAAJ6 | 3 | 6 | 1 | * |
| | 68 | A | F930J686MAAAJ6 | 4.3 | 20 | 2 | * |
| | 68 | B | F930J686MBAAJ6 | 4.3 | 8 | 1 | * |
| 10V | 100 | B | F930J107MBAAJ6 | 6.3 | 14 | 0.9 | * |
| | 100 | C | F930J107MCCAJ6 | 6.3 | 8 | 0.7 | * |
| | 150 | B | F930J157MBAAJ6 | 9.5 | 18 | 0.9 | * |
| | 150 | C | F930J157MCCAJ6 | 9.5 | 12 | 0.7 | * |
| | 220 | C | F930J227MCCAJ6 | 13.9 | 14 | 0.7 | * |
| | 220 | N | F930J227MNCAJ6 | 13.9 | 10 | 0.5 | * |
| | 330 | N | F930J337MNCAJ6 | 20.8 | 14 | 0.5 | * |
| | 470 | N | F930J477MNCAJ6 | 29.6 | 16 | 0.3 | * |
| | 6.8 | A | F931A685MAAAJ6 | 0.7 | 6 | 3.5 | * |
| | 10 | A | F931A106MAAAJ6 | 1 | 6 | 3 | * |
| 15 | A | F931A156MAAAJ6 | 1.5 | 8 | 2.9 | * | |
| 22 | A | F931A226MAAAJ6 | 2.2 | 12 | 2.5 | * | |
| 22 | B | F931A226MBAAJ6 | 2.2 | 6 | 1.9 | * | |
| 33 | A | F931A336MAAAJ6 | 3.3 | 18 | 2.5 | * | |
| 33 | B | F931A336MBAAJ6 | 3.3 | 8 | 1.4 | * | |
| 47 | B | F931A476MBAAJ6 | 4.7 | 8 | 1 | * | |
| 47 | C | F931A476MCCAJ6 | 4.7 | 6 | 0.9 | * | |
| 68 | B | F931A686MBAAJ6 | 6.8 | 12 | 0.9 | ±15 | |
| 68 | C | F931A686MCCAJ6 | 6.8 | 8 | 0.8 | * | |
| 100 | C | F931A107MCCAJ6 | 10 | 10 | 0.7 | * | |
| 100 | N | F931A107MNCAJ6 | 10 | 8 | 0.6 | * | |
| 150 | N | F931A157MNCAJ6 | 15 | 10 | 0.6 | * | |
| 220 | N | F931A227MNCAJ6 | 22 | 12 | 0.5 | * | |
| 330 | N | F931A337MNCAJ6 | 33 | 18 | 0.5 | * | |

1: ΔC/C Marked “”

| Item | All Case (%) |
|------------------------------|--------------|
| Damp heat, steady state | ±10 |
| Rapid change of temperature | ±10 |
| Resistance to soldering heat | ±10 |
| Surge | ±10 |
| Endurance | ±10 |

| Rated Volt | Rated Capacitance (µF) | Case Code | Part Number | Leakage Current (µA) | Dissipation Factor (%@120Hz) | ESR (Ω@100kHz) | *1 ΔC/C (%) |
|------------|------------------------|----------------|----------------|----------------------|------------------------------|----------------|-------------|
| 16V | 1 | A | F931C105MAAAJ6 | 0.5 | 4 | 7.5 | * |
| | 2.2 | A | F931C225MAAAJ6 | 0.5 | 4 | 5 | * |
| | 3.3 | A | F931C335MAAAJ6 | 0.5 | 4 | 4.5 | * |
| | 4.7 | A | F931C475MAAAJ6 | 0.8 | 6 | 4 | * |
| | 6.8 | A | F931C685MAAAJ6 | 1.1 | 6 | 3.5 | * |
| | 10 | A | F931C106MAAAJ6 | 1.6 | 6 | 3 | * |
| | 10 | B | F931C106MBAAJ6 | 1.6 | 6 | 2 | * |
| | 15 | A | F931C156MAAAJ6 | 2.4 | 10 | 3 | * |
| | 15 | B | F931C156MBAAJ6 | 2.4 | 6 | 2 | * |
| | 22 | B | F931C226MBAAJ6 | 3.5 | 8 | 1.9 | * |
| 20V | 22 | C | F931C226MCCAJ6 | 3.5 | 6 | 1.1 | * |
| | 33 | B | F931C336MBAAJ6 | 5.3 | 8 | 1.9 | * |
| | 33 | C | F931C336MCCAJ6 | 5.3 | 6 | 1.1 | * |
| | 47 | C | F931C476MCCAJ6 | 7.5 | 8 | 0.9 | * |
| | 47 | N | F931C476MNCAJ6 | 7.5 | 6 | 0.7 | * |
| | 68 | N | F931C686MNCAJ6 | 10.9 | 6 | 0.6 | * |
| | 100 | N | F931C107MNCAJ6 | 16 | 10 | 0.6 | * |
| | 150 | N | F931C157MNCAJ6 | 24 | 15 | 0.6 | * |
| | 2.2 | A | F931D225MAAAJ6 | 0.5 | 4 | 5 | * |
| | 3.3 | A | F931D335MAAAJ6 | 0.7 | 4 | 4.5 | * |
| 25V | 4.7 | A | F931D475MAAAJ6 | 0.9 | 6 | 3 | * |
| | 4.7 | B | F931D475MBAAJ6 | 0.9 | 6 | 2.8 | * |
| | 6.8 | A | F931D685MAAAJ6 | 1.4 | 6 | 3.5 | * |
| | 6.8 | B | F931D685MBAAJ6 | 1.4 | 6 | 2.5 | * |
| | 10 | A | F931D106MAAAJ6 | 2 | 8 | 3.5 | * |
| | 10 | B | F931D106MBAAJ6 | 2 | 6 | 2.1 | * |
| | 15 | C | F931D156MCCAJ6 | 3 | 6 | 1.2 | * |
| | 22 | B | F931D226MBAAJ6 | 4.4 | 8 | 1.9 | * |
| | 22 | C | F931D226MCCAJ6 | 4.4 | 8 | 1.1 | * |
| | 33 | C | F931D336MCCAJ6 | 6.6 | 8 | 1.1 | * |
| 35V | 33 | N | F931D336MNCAJ6 | 6.6 | 6 | 0.7 | * |
| | 47 | C | F931D476MCCAJ6 | 9.4 | 10 | 1.1 | * |
| | 47 | N | F931D476MNCAJ6 | 9.4 | 8 | 0.7 | * |
| | 1 | A | F931E105MAAAJ6 | 0.5 | 4 | 7.5 | * |
| | 1.5 | A | F931E155MAAAJ6 | 0.5 | 4 | 6.7 | * |
| | 2.2 | A | F931E225MAAAJ6 | 0.6 | 6 | 6.3 | * |
| | 3.3 | A | F931E335MAAAJ6 | 0.8 | 6 | 6 | * |
| | 4.7 | A | F931E475MAAAJ6 | 1.2 | 8 | 4 | * |
| | 4.7 | B | F931E475MBAAJ6 | 1.2 | 6 | 2.8 | * |
| | 10 | B | F931E106MBAAJ6 | 2.5 | 12 | 1.9 | * |
| 10 | C | F931E106MCCAJ6 | 2.5 | 6 | 1.5 | * | |
| 15 | C | F931E156MCCAJ6 | 3.8 | 8 | 1.2 | * | |
| 22 | C | F931E226MCCAJ6 | 5.5 | 8 | 1.1 | * | |
| 22 | N | F931E226MNCAJ6 | 5.5 | 6 | 0.7 | * | |
| 33 | N | F931E336MNCAJ6 | 8.3 | 8 | 0.7 | * | |
| 47 | N | F931E476MNCAJ6 | 11.8 | 8 | 0.7 | * | |
| 1 | A | F931V105MAAAJ6 | 0.5 | 4 | 7.5 | * | |
| 1.5 | A | F931V155MAAAJ6 | 0.5 | 6 | 7.5 | * | |
| 2.2 | A | F931V225MAAAJ6 | 0.8 | 6 | 7 | * | |
| 2.2 | B | F931V225MBAAJ6 | 0.8 | 4 | 3.8 | * | |
| 3.3 | B | F931V335MBAAJ6 | 1.2 | 4 | 3.5 | * | |
| 4.7 | B | F931V475MBAAJ6 | 1.6 | 8 | 3.1 | * | |
| 4.7 | C | F931V475MCCAJ6 | 1.6 | 6 | 1.8 | * | |
| 6.8 | C | F931V685MCCAJ6 | 2.4 | 6 | 1.8 | * | |
| 10 | C | F931V106MCCAJ6 | 3.5 | 6 | 1.6 | * | |
| 15 | N | F931V156MNCAJ6 | 5.3 | 6 | 0.7 | * | |
| 22 | N | F931V226MNCAJ6 | 7.7 | 8 | 0.7 | * | |

* In case of capacitance tolerance ± 10% type, “K” will be put at 9th digit of type numbering system

Standard Microchip

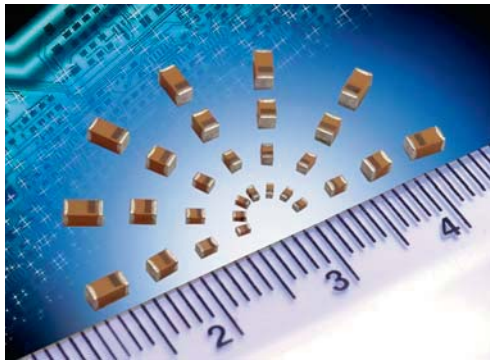

- The world's smallest surface mount tantalum capacitor
- CV range: 0.10-150µF / 2-25V
- 5 case sizes available
- Low profile options available
- Industrial and hi-rel medical applications



LEAD-FREE
LEAD-FREE COMPATIBLE
COMPONENT



CASE DIMENSIONS: millimeters (inches)

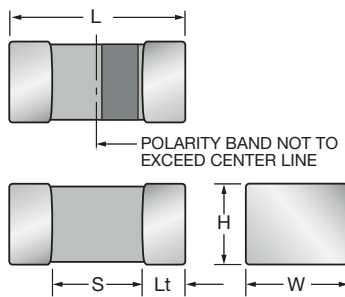

| Code | EIA Code | EIA Metric | L+0.20 (0.008) -0.00 (0.000) | W+0.15 (0.006) -0.00 (0.000) | H+0.15 (0.006) -0.00 (0.000) | Termination Spacing(S) | Minimum Termination Length (Lt) |
|------|----------|------------|---------------------------------|---|---|------------------------|---------------------------------|
| A | 1206 | 3216-18 | 3.20 ± 0.20 (0.126 ± 0.008) | 1.60 ± 0.20 (0.06 ± 0.008) | 1.60 ± 0.20 (0.063 ± 0.008) | 1.80 (0.071) min | 0.15 (0.006) |
| B | 1210 | 3528-15 | 3.50 ± 0.20 (0.138 ± 0.008) | 2.80 +0.20 -0.10 (0.110 +0.008 -0.004) | 1.50 (0.059) max | 2.00 (0.079) min | 0.15 (0.006) |
| K | 0402 | 1005-07 | 1.00 (0.039) | 0.50 +0.20 -0.00 (0.020 +0.008 -0.000) | 0.50 +0.20 -0.00 (0.020 +0.008 -0.000) | 0.40 (0.016) min | 0.10 (0.004) |
| L | 0603 | 1608-10 | 1.60 (0.063) | 0.85 (0.033) | 0.85 (0.033) | 0.55 (0.022) min | 0.15 (0.006) |
| R | 0805 | 2012-15 | 2.00 (0.079) | 1.35 (0.053) | 1.35 (0.053) | 0.70 (0.027) min | 0.15 (0.006) |

HOW TO ORDER

| | | | | | | |
|-----------------------|------------------------------|--|-------------------------------|--|---|---|
| TAC | L | 226 | M | 004 | R | TA |
| Type TACmicrochip® | Case Size See table above | Capacitance Code pF code: 1st two digits represent significant figures, 3rd digit represents multiplier (number of zeros to follow) | Tolerance K=±10% M=±20% | Rated DC Voltage 002=2Vdc 003=3Vdc 004=4Vdc 006=6.3Vdc 010=10Vdc 016=16Vdc 020=20Vdc 025=25Vdc 035=35Vdc 050=50Vdc | Packaging R, P = 7" Standard Tin Termination Plastic Tape X, Q = 4 1/4" Standard Tin Termination Plastic Tape A = 7" Gold Termination Plastic Tape F = 4 1/4" Gold Termination Plastic Tape | Alternative characters may be used for special requirements |

TECHNICAL SPECIFICATIONS

| | | | | | | | | | | | |
|------------------------------------|--|-----|-----|-----|-----|----|----|----|----|----|----|
| Technical Data: | All technical data relate to an ambient temperature of +25°C | | | | | | | | | | |
| Capacitance Range: | 0.10 µF to 150 µF | | | | | | | | | | |
| Capacitance Tolerance: | ±10%; ±20% | | | | | | | | | | |
| Leakage Current DCL: | 0.01CV or 0.5µA whichever is the greater | | | | | | | | | | |
| Rated Voltage (V _R) | ≤ +85°C: | 2 | 3 | 4 | 6.3 | 10 | 16 | 20 | 25 | 35 | 50 |
| Category Voltage (V _C) | ≤ +125°C: | 1.3 | 2 | 2.7 | 4 | 7 | 10 | 13 | 17 | 23 | 33 |
| Surge Voltage (V _S) | ≤ +85°C: | 2.7 | 3.9 | 5.2 | 8 | 13 | 20 | 26 | 32 | 46 | 65 |
| Surge Voltage (V _S) | ≤ +125°C: | 1.7 | 2.6 | 3.2 | 5 | 8 | 12 | 16 | 20 | 28 | 40 |
| Temperature Range: | -55°C to +125°C | | | | | | | | | | |
| Reliability: | 1% per 1000 hours at 85°C, V _R with 0.1Ω/V series impedance, 60% confidence level | | | | | | | | | | |
| Termination Finish: | Nickel and Tin Plating (standard), Nickel and Gold Plating option available upon request | | | | | | | | | | |

STANDARD COMMERCIAL RANGE (EIA SIZES) (LETTER DENOTES CASE SIZE)

| Capacitance | | Voltage Rating DC (V _R) at 85°C | | | | | | | | | |
|-------------|------|---|------------------------------------|------------------------------------|---------------------|--|---------------------|------------------|-----|-----|-----|
| µF | Code | 2.0V | 3.0V | 4.0V | 6.3V | 10V | 16V | 20V | 25V | 35V | 50V |
| 0.10 | 104 | | | | | | K ^(M) | K* | | L* | |
| 0.15 | 154 | | | | | | K ^(M) | K ^(M) | | | |
| 0.22 | 224 | | | | | | K ^(M) | K ^(M) | | L* | |
| 0.33 | 334 | | | | | | K ^(M) | | | | |
| 0.47 | 474 | | | | | | K ^(M) /L | L | | | |
| 0.68 | 684 | | | | | | K ^(M) /L | L | | | |
| 1.0 | 105 | | | | K/L | K/L | L | | R | | A* |
| 1.5 | 155 | | | L | L | L | | | | | |
| 2.2 | 225 | | K ^(M) /L | L | K ^(M) /L | L | L | | | | |
| 3.3 | 335 | K ^(M) /L | K ^(M) /L | L | L | L/R | R* | R ^(M) | | | |
| 4.7 | 475 | K ^(M) /L | K ^(M) /L | L | L | L/R | | R ^(M) | A* | | |
| 6.8 | 685 | K ^(M) /L | L | L | L/R | L/R | | | | | |
| 10 | 106 | K ^(M) /L | L | L/R | L ^(M) /R | L/R | R | | | | |
| 15 | 156 | | R | L ^(M) /R | L ^(M) /R | R | | | | | |
| 22 | 226 | R | L ^(M) /R | L ^(M) /R | R | R | | | | | |
| 33 | 336 | R | R | R | R | A ^(M) /B ^(M) /R ^(M) | | | | | |
| 47 | 476 | R | R | R | R | B | | | | | |
| 68 | 686 | R ^(M) | R ^(M) | A ^(M) | A ^{(M)*} | | | | | | |
| 100 | 107 | | A ^(M) /R ^(M) | A ^(M) /R ^(M) | A ^(M) | | | | | | |
| 150 | 157 | A ^(M) | | | | | | | | | |
| 220 | 227 | | | | | | | | | | |

ESR limits quoted in brackets (Ohms)

Released codes ^(M tolerance only)

Engineering samples - please contact manufacturer

*Codes under development - subject to change.

Standard Height Profile: A, B, K, L, R Case

Low Profile: H, J, T, U, V Case

Note: Voltage ratings are minimum values. AVX reserves the right to supply higher ratings in the same case size, to the same reliability standards.

RATINGS & PART NUMBER REFERENCE

| AVX Part No. | EIA Code | EIA Metric | Case Size | Cap (µF) | Rated Voltage (V) | DCL (µA) Max. | DF % Max. | ESR Max. (Ω) @100kHz | MSL |
|---|----------|------------|-----------|----------|-------------------|---------------|-----------|----------------------|-----|
| 2 Volt @ 85°C (1.3 Volt @ 125°C) | | | | | | | | | |
| TACK335M002#TA | 0402 | 1005-07 | K | 3.3 | 2 | 0.5 | 8 | 15 | 1 |
| TACL335*002#TA | 0603 | 1608-10 | L | 3.3 | 2 | 0.5 | 6 | 7.5 | 1 |
| TACK475M002#TA | 0402 | 1005-07 | K | 4.7 | 2 | 0.5 | 12 | 15 | 1 |
| TACL475*002#TA | 0603 | 1608-10 | L | 4.7 | 2 | 0.5 | 6 | 7.5 | 1 |
| TACK685M002#TA | 0402 | 1005-07 | K | 6.8 | 2 | 0.5 | 20 | 15 | 1 |
| TACL685*002#TA | 0603 | 1608-10 | L | 6.8 | 2 | 0.5 | 6 | 7.5 | 1 |
| TACK106M002#TA | 0402 | 1005-07 | K | 10 | 2 | 0.5 | 15 | 15 | 1 |
| TACL106*002#TA | 0603 | 1608-10 | L | 10 | 2 | 0.5 | 10 | 7.5 | 1 |
| TACR226*002#TA | 0805 | 2012-15 | R | 22 | 2 | 0.5 | 8 | 5 | 1 |
| TACR336*002#TA | 0805 | 2012-15 | R | 33 | 2 | 0.7 | 10 | 5 | 1 |
| TACR476*002#TA | 0805 | 2012-15 | R | 47 | 2 | 0.9 | 10 | 5 | 1 |
| TACR686M002#TA | 0805 | 2012-15 | R | 68 | 2 | 1.4 | 14 | 5 | 1 |
| TACA157M002#TA | 1206 | 3216-18 | A | 150 | 2 | 3 | 20 | 1 | 1 |
| 3 Volt @ 85°C (2 Volt @ 125°C) | | | | | | | | | |
| TACK225M003#TA | 0402 | 1005-07 | K | 2.2 | 3 | 0.5 | 6 | 15 | 1 |
| TACL225*003#TA | 0603 | 1608-10 | L | 2.2 | 3 | 0.5 | 6 | 7.5 | 1 |
| TACK335M003#TA | 0402 | 1005-07 | K | 3.3 | 3 | 0.5 | 8 | 15 | 1 |
| TACL335*003#TA | 0603 | 1608-10 | L | 3.3 | 3 | 0.5 | 6 | 7.5 | 1 |
| TACK475M003#TA | 0402 | 1005-07 | K | 4.7 | 3 | 0.5 | 12 | 15 | 1 |
| TACL475*003#TA | 0603 | 1608-10 | L | 4.7 | 3 | 0.5 | 6 | 7.5 | 1 |
| TACL685*003#TA | 0603 | 1608-10 | L | 6.8 | 3 | 0.5 | 6 | 7.5 | 1 |
| TACL106*003#TA | 0603 | 1608-10 | L | 10 | 3 | 0.5 | 10 | 7.5 | 1 |
| TACR156*003#TA | 0805 | 2012-15 | R | 15 | 3 | 0.5 | 8 | 5 | 1 |
| TACL226M003#TA | 0603 | 1608-10 | L | 22 | 3 | 0.7 | 20 | 7.5 | 1 |
| TACR226*003#TA | 0805 | 2012-15 | R | 22 | 3 | 0.7 | 8 | 5 | 1 |
| TACR336*003#TA | 0805 | 2012-15 | R | 33 | 3 | 1 | 10 | 5 | 1 |
| TACR476*003#TA | 0805 | 2012-15 | R | 47 | 3 | 1.5 | 10 | 5 | 1 |
| TACR686M003#TA | 0805 | 2012-15 | R | 68 | 3 | 2 | 14 | 5 | 1 |
| TACA107M003#TA | 1206 | 3216-18 | A | 100 | 3 | 3 | 15 | 1 | 1 |
| TACR107M003#TA | 0805 | 2012-15 | R | 100 | 3 | 3 | 30 | 5 | 1 |
| 4 Volt @ 85°C (2.7 Volt @ 125°C) | | | | | | | | | |
| TACL155*004#TA | 0603 | 1608-10 | L | 1.5 | 4 | 0.5 | 6 | 7.5 | 1 |
| TACL225*004#TA | 0603 | 1608-10 | L | 2.2 | 4 | 0.5 | 6 | 7.5 | 1 |
| TACL335*004#TA | 0603 | 1608-10 | L | 3.3 | 4 | 0.5 | 6 | 7.5 | 1 |
| TACL475*004#TA | 0603 | 1608-10 | L | 4.7 | 4 | 0.5 | 6 | 7.5 | 1 |
| TACL685*004#TA | 0603 | 1608-10 | L | 6.8 | 4 | 0.5 | 8 | 7.5 | 1 |
| TACL106*004#TA | 0603 | 1608-10 | L | 10 | 4 | 0.5 | 10 | 7.5 | 1 |
| TACR106*004#TA | 0805 | 2012-15 | R | 10 | 4 | 0.5 | 8 | 5 | 1 |
| TACL156M004#TA | 0603 | 1608-10 | L | 15 | 4 | 0.6 | 20 | 7.5 | 1 |
| TACR156*004#TA | 0805 | 2012-15 | R | 15 | 4 | 0.6 | 8 | 5 | 1 |
| TACL226M004#TA | 0603 | 1608-10 | L | 22 | 4 | 0.9 | 20 | 7.5 | 1 |
| TACR226*004#TA | 0805 | 2012-15 | R | 22 | 4 | 0.9 | 8 | 5 | 1 |
| TACR336*004#TA | 0805 | 2012-15 | R | 33 | 4 | 1.3 | 10 | 5 | 1 |
| TACR476*004#TA | 0805 | 2012-15 | R | 47 | 4 | 1.9 | 14 | 5 | 1 |
| TACA686M004#TA | 1206 | 3216-18 | A | 68 | 4 | 2.7 | 15 | 1 | 1 |
| TACA107M004#TA | 1206 | 3216-18 | A | 100 | 4 | 4 | 20 | 1 | 1 |
| TACR107M004#TA | 0805 | 2012-15 | R | 100 | 4 | 4 | 30 | 5 | 1 |
| 6.3 Volt @ 85°C (4 Volt @ 125°C) | | | | | | | | | |
| TACK105*006#TA | 0402 | 1005-07 | K | 1 | 6.3 | 0.5 | 6 | 15 | 1 |
| TACL105*006#TA | 0603 | 1608-10 | L | 1 | 6.3 | 0.5 | 6 | 7.5 | 1 |
| TACL155*006#TA | 0603 | 1608-10 | L | 1.5 | 6.3 | 0.5 | 6 | 7.5 | 1 |
| TACK225M006#TA | 0402 | 1005-07 | K | 2.2 | 6.3 | 0.5 | 8 | 15 | 1 |
| TACL225*006#TA | 0603 | 1608-10 | L | 2.2 | 6.3 | 0.5 | 6 | 7.5 | 1 |
| TACL335*006#TA | 0603 | 1608-10 | L | 3.3 | 6.3 | 0.5 | 6 | 7.5 | 1 |
| TACL475*006#TA | 0603 | 1608-10 | L | 4.7 | 6.3 | 0.5 | 8 | 7.5 | 1 |
| TACL685*006#TA | 0603 | 1608-10 | L | 6.8 | 6.3 | 0.5 | 10 | 7.5 | 1 |
| TACR685*006#TA | 0805 | 2012-15 | R | 6.8 | 6.3 | 0.5 | 8 | 5 | 1 |

| AVX Part No. | EIA Code | EIA Metric | Case Size | Cap (µF) | Rated Voltage (V) | DCL (µA) Max. | DF % Max. | ESR Max. (Ω) @100kHz | MSL |
|---|----------|------------|-----------|----------|-------------------|---------------|-----------|----------------------|-----|
| TACL106M006#TA | 0603 | 1608-10 | L | 10 | 6.3 | 0.6 | 10 | 6 | 1 |
| TACR106*006#TA | 0805 | 2012-15 | R | 10 | 6.3 | 0.6 | 8 | 5 | 1 |
| TACL156M006#TA | 0603 | 1608-10 | L | 15 | 6.3 | 0.9 | 20 | 7.5 | 1 |
| TACR156*006#TA | 0805 | 2012-15 | R | 15 | 6.3 | 0.9 | 8 | 5 | 1 |
| TACR226*006#TA | 0805 | 2012-15 | R | 22 | 6.3 | 1.4 | 10 | 5 | 1 |
| TACR336*006#TA | 0805 | 2012-15 | R | 33 | 6.3 | 2.1 | 12 | 5 | 1 |
| TACA476*006#TA | 1206 | 3216-18 | A | 47 | 6.3 | 3 | 15 | 1 | 1 |
| TACR476M006#TA | 0805 | 2012-15 | R | 47 | 6.3 | 3 | 20 | 5 | 1 |
| TACA686M006#TA | 1206 | 3216-18 | A | 68 | 6.3 | 4.3 | 15 | 1 | 1 |
| TACA107M006#TA | 1206 | 3216-18 | A | 100 | 6.3 | 6.3 | 20 | 1 | 1 |
| 10 Volt @ 85°C (7 Volt @ 125°C) | | | | | | | | | |
| TACK154M010#TA | 0402 | 1005-07 | K | 0.15 | 10 | 0.5 | 6 | 40 | 1 |
| TACK224M010#TA | 0402 | 1005-07 | K | 0.22 | 10 | 0.5 | 6 | 30 | 1 |
| TACK334M010#TA | 0402 | 1005-07 | K | 0.33 | 10 | 0.5 | 6 | 20 | 1 |
| TACK474M010#TA | 0402 | 1005-07 | K | 0.47 | 10 | 0.5 | 6 | 15 | 1 |
| TACL474*010#TA | 0603 | 1608-10 | L | 0.47 | 10 | 0.5 | 6 | 7.5 | 1 |
| TACK684M010#TA | 0402 | 1005-07 | K | 0.68 | 10 | 0.5 | 8 | 15 | 1 |
| TACL684*010#TA | 0603 | 1608-10 | L | 0.68 | 10 | 0.5 | 6 | 7.5 | 1 |
| TACK105*010#TA | 0402 | 1005-07 | K | 1 | 10 | 0.5 | 6 | 15 | 1 |
| TACL105*010#TA | 0603 | 1608-10 | L | 1 | 10 | 0.5 | 6 | 7.5 | 1 |
| TACL155*010#TA | 0603 | 1608-10 | L | 1.5 | 10 | 0.5 | 6 | 7.5 | 1 |
| TACL225*010#TA | 0603 | 1608-10 | L | 2.2 | 10 | 0.5 | 6 | 7.5 | 1 |
| TACL335*010#TA | 0603 | 1608-10 | L | 3.3 | 10 | 0.5 | 8 | 7.5 | 1 |
| TACR335*010#TA | 0805 | 2012-15 | R | 3.3 | 10 | 0.5 | 8 | 5 | 1 |
| TACL475*010#TA | 0603 | 1608-10 | L | 4.7 | 10 | 0.5 | 10 | 6 | 1 |
| TACR475*010#TA | 0805 | 2012-15 | R | 4.7 | 10 | 0.5 | 8 | 6 | 1 |
| TACL685*010#TA | 0603 | 1608-10 | L | 6.8 | 10 | 0.7 | 20 | 7.5 | 1 |
| TACR685*010#TA | 0805 | 2012-15 | R | 6.8 | 10 | 0.7 | 8 | 5 | 1 |
| TACL106*010#TA | 0603 | 1608-10 | L | 10 | 10 | 1 | 20 | 7.5 | 1 |
| TACR106*010#TA | 0805 | 2012-15 | R | 10 | 10 | 1 | 8 | 5 | 1 |
| TACR156*010#TA | 0805 | 2012-15 | R | 15 | 10 | 1.5 | 10 | 5 | 1 |
| TACR226*010#TA | 0805 | 2012-15 | R | 22 | 10 | 2.2 | 14 | 5 | 1 |
| TACA336M010#TA | 1206 | 3216-18 | A | 33 | 10 | 3.3 | 12 | 1 | 1 |
| TACB336*010#TA | 1210 | 3528-15 | B | 33 | 10 | 3.3 | 15 | 1 | 1 |
| TACR336M010#TA | 0805 | 2012-15 | R | 33 | 10 | 3.3 | 20 | 5 | 1 |
| TACB476*010#TA | 1210 | 3528-15 | B | 47 | 10 | 4.7 | 15 | 1 | 1 |
| 16 Volt @ 85°C (10 Volt @ 125°C) | | | | | | | | | |
| TACK104M016#TA | 0402 | 1005-07 | K | 0.1 | 16 | 0.5 | 6 | 40 | 1 |
| TACK154M016#TA | 0402 | 1005-07 | K | 0.15 | 16 | 0.5 | 6 | 30 | 1 |
| TACK224M016#TA | 0402 | 1005-07 | K | 0.22 | 16 | 0.5 | 6 | 20 | 1 |
| TACK334M016#TA | 0402 | 1005-07 | K | 0.33 | 16 | 0.5 | 6 | 20 | 1 |
| TACL474*016#TA | 0603 | 1608-10 | L | 0.47 | 16 | 0.5 | 6 | 7.5 | 1 |
| TACL684*016#TA | 0603 | 1608-10 | L | 0.68 | 16 | 0.5 | 6 | 7.5 | 1 |
| TACL105*016#TA | 0603 | 1608-10 | L | 1 | 16 | 0.5 | 6 | 7.5 | 1 |
| TACL225*016#TA | 0603 | 1608-10 | L | 2.2 | 16 | 0.5 | 10 | 7.5 | 1 |
| TACR335*016#TA | 0805 | 2012-15 | R | 3.3 | 16 | 0.5 | 8 | 5 | 1 |
| TACR106*016#TA | 0805 | 2012-15 | R | 10 | 16 | 1.6 | 10 | 5 | 1 |
| 20 Volt @ 85°C (13 Volt @ 125°C) | | | | | | | | | |
| TACK104*020#TA | 0402 | 1005-07 | K | 0.10 | 20 | 0.5 | 6 | 40 | 1 |
| TACK224M020#TA | 0402 | 1005-07 | K | 0.22 | 20 | 0.5 | 6 | 20 | 1 |
| TACR335M020#TA | 0805 | 2012-15 | R | 3.3 | 20 | 0.7 | 8 | 5 | 1 |
| TACR475M020#TA | 0805 | 2012-15 | R | 47 | 20 | 0.9 | 8 | 5 | 1 |
| 25 Volt @ 85°C (17 Volt @ 125°C) | | | | | | | | | |
| TACR105*025#TA | 0805 | 2012-15 | R | 1 | 25 | 0.5 | 8 | 5 | 1 |
| TACA475*025#TA | 1206 | 3216-18 | A | 47 | 25 | 1.2 | 8 | 1 | 1 |
| 50 Volt @ 85°C (33 Volt @ 125°C) | | | | | | | | | |
| TACA105*050#TA | 1206 | 3216-18 | A | 1.0 | 50 | 0.5 | 6 | 1 | 1 |

Moisture Sensitivity Level (MSL) is defined according to J-STD-020.

All technical data relates to an ambient temperature of +25°C. Capacitance and DF are measured at 120Hz, 0.5V RMS with a maximum DC bias of 2.2 volts. DCL is measured at rated voltage after 5 minutes.

For typical weight and composition see page 144.

NOTE: AVX reserves the right to supply a higher voltage rating or tighter tolerance part in the same case size, to the same reliability standards.

F95 Series



Standard Conformal Coated Chip

FRAMELESS™



For SMD



Smaller



For High Frequency



- Compliant to the RoHS directive (2002/95/EC).

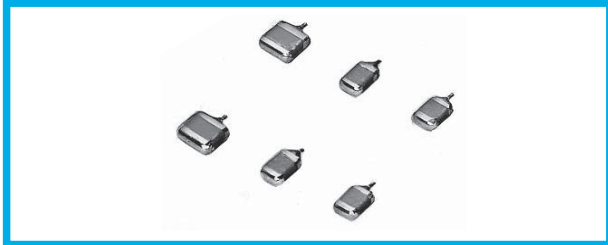

Applications

- Smartphone
- Wireless module
- Tablet PC
- e-book

Type numbering system (Example: 4V 330 μF)

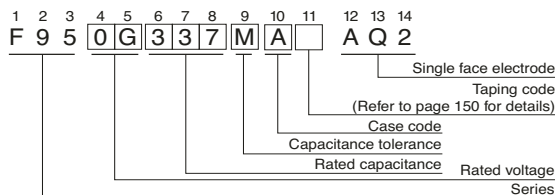

Drawing

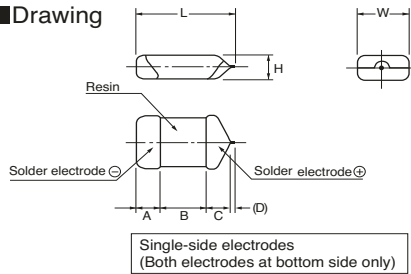

Dimensions

| Case code | L | W | H | A | B | C | (D) |
|-----------|-----------|------------|-----------|-----------|-----------|-----------|-------|
| R | 2.2 ± 0.3 | 1.25 ± 0.3 | 0.65MAX. | 0.6 ± 0.3 | 0.8 ± 0.3 | 0.5MIN | (0.2) |
| P | 2.2 ± 0.3 | 1.25 ± 0.3 | 1.0 ± 0.2 | 0.6 ± 0.3 | 0.8 ± 0.3 | 0.8 ± 0.3 | (0.2) |
| Q | 3.2 ± 0.2 | 1.6 ± 0.2 | 0.8 ± 0.2 | 0.8 ± 0.2 | 1.2 ± 0.2 | 0.8 ± 0.2 | (0.2) |
| S | 3.2 ± 0.3 | 1.6 ± 0.3 | 1.0 ± 0.2 | 0.8 ± 0.3 | 1.2 ± 0.3 | 0.8 ± 0.3 | (0.2) |
| A | 3.2 ± 0.3 | 1.7 ± 0.3 | 1.4 ± 0.2 | 0.8 ± 0.3 | 1.2 ± 0.3 | 0.8 ± 0.3 | (0.2) |
| T | 3.5 ± 0.2 | 2.7 ± 0.2 | 1.0 ± 0.2 | 0.8 ± 0.2 | 1.2 ± 0.2 | 1.1 ± 0.2 | (0.2) |
| B | 3.5 ± 0.2 | 2.8 ± 0.2 | 1.8 ± 0.2 | 0.8 ± 0.3 | 1.2 ± 0.3 | 1.1 ± 0.3 | (0.2) |

D dimension only for reference

Standard Ratings

| Cap. (μF) | Code | V | | | | | | | |
|-----------|------|-------------------------|-----------------------|-------------------------|-------------------|-----------|----|----|--|
| | | 4 | 6.3 | 10 | 16 | 20 | 25 | 35 | |
| 1 | 105 | 0G | 0J | 1A | 1C | | | | |
| 1.5 | 155 | | | | | | | | |
| 2.2 | 225 | | | | | | | | |
| 3.3 | 335 | | | | | | | | |
| 4.7 | 475 | | | | | | | | |
| 6.8 | 685 | | | | | | | | |
| 10 | 106 | | | R · P | P · Q · S · A | S · A · B | | | |
| 15 | 156 | | | P | S · A | | | | |
| 22 | 226 | | R | P · Q · S · A | Q · S · A · T · B | B | | | |
| 33 | 336 | | (R) · P | P · Q · S · A | (A) · T · B | | | | |
| 47 | 476 | (R) | P | P · (Q) · S · A · T · B | B | | | | |
| 68 | 686 | | P | B | | | | | |
| 100 | 107 | P · S · A | P · Q · S · A · T · B | (S) · A · T · B | | | | | |
| 150 | 157 | P · B | B | | | | | | |
| 220 | 227 | (P) · Q · S · A · T · B | (S) · (A) · (T) · B | | | | | | |
| 330 | 337 | (P) · (S) · A · T · B | B | | | | | | |
| 470 | 477 | (P) · (A) · (T) · B | (B) | | | | | | |
| 680 | 687 | (T) | | | | | | | |

() The series in parentheses are being developed. Please contact to your local AVX sales office when these series are being designed in your application.



Specifications

| Item | Performance Characteristics |
|-----------------------------------|---|
| Category | -55 to +125°C (Rated temperature : +85°C) |
| Temperature Range | |
| Capacitance Tolerance | ±20%, ±10% (at 120Hz) (However R · P Case ±20%) |
| Dissipation Factor (at 120Hz) | Refer to next page |
| ESR(100kHz) | Refer to next page |
| Leakage Current | Refer to next page Provided that • After 1 minute's application of rated voltage, leakage current at 85°C, 10 times or less than 20°C specified value. • After 1 minute's application of rated voltage, leakage current at 125°C, 12.5 times or less than 20°C specified value. |
| Capacitance Change by Temperature | +15% Max. (at +125°C) +10% Max. (at +85°C) -10% Max. (at -55°C) |
| Damp Heat (Steady State) | At 40°C, 90 to 95% R.H., For 500 hours (No voltage applied) Capacitance Change Refer to next page (*1) Dissipation Factor Initial specified value or less Leakage Current Initial specified value or less |
| Temperature Cycles | At -55°C / +125°C, 30 minutes each, For 5 cycles, Capacitance Change Refer to next page (*1) Dissipation Factor Initial specified value or less Leakage Current Initial specified value or less |
| Resistance to Soldering Heat | 10 seconds reflow at 260°C, 10 seconds immersion at 260°C Capacitance Change Refer to next page (*1) Dissipation Factor Initial specified value or less Leakage Current Initial specified value or less |
| Surge | After application of surge voltage in series with a 33Ω resistor at the rate of 30 seconds ON, 30 seconds OFF, for 1000 successive test cycles at 85°C, capacitors shall meet the characteristic requirements table below. Capacitance Change Refer to next page (*1) Dissipation Factor Initial specified value or less Leakage Current Initial specified value or less |
| Endurance | After 2000 hours' application of rated voltage at 85°C, capacitors shall meet the characteristic requirements table below. Capacitance Change Refer to next page (*1) Dissipation Factor Initial specified value or less Leakage Current Initial specified value or less |
| Shear Test | After applying the pressure load of 5N for 10 ± 1 seconds horizontally to the center of capacitor side body which has no electrode and has been soldered beforehand on a substrate, there shall be found neither exfoliation nor its sign at the terminal electrode. 5N (0.51kg · f) For 10 ± 1 seconds |
| Terminal Strength | Keeping a capacitor surface-mounted on a substrate upside down and supporting the substrate at both of the opposite bottom points 45mm apart from the center of capacitor, the pressure strength is applied with a specified jig at the center of substrate so that the substrate may bend by 1mm as illustrated. Then, there shall be found no remarkable abnormality on the capacitor terminals. R230 20 45 45 1mm |

F95 Series



Standard Conformal Coated Chip

Standard Ratings

| Rated Volt | Rated Capacitance (μF) | Case code | Part Number | *2 Leakage Current (μA) | Dissipation Factor (% @ 120Hz) | ESR (Ω @ 100kHz) | *1 ΔC/C (%) | |
|------------|------------------------|-----------|----------------|-------------------------|--------------------------------|------------------|-------------|-----|
| 4V | 100 | P | F950G107MPAAQ2 | 4.0 | 30 | 1.2 | ±15 | |
| | 100 | S | F950G107MSAAQ2 | 4.0 | 14 | 0.8 | * | |
| | 100 | A | F950G107MAAAQ2 | 4.0 | 12 | 0.5 | * | |
| | 150 | P | F950G157MPAAQ2 | 12.0 | 31 | 1.1 | ±20 | |
| | 150 | B | F950G157MBAAQ2 | 6.0 | 14 | 0.4 | * | |
| | 220 | Q | F950G227MQAAQ2 | 8.8 | 30 | 1.5 | ±20 | |
| | 220 | S | F950G227MSAAQ2 | 8.8 | 30 | 0.8 | ±15 | |
| | 220 | A | F950G227MAAAQ2 | 8.8 | 25 | 0.8 | ±15 | |
| | 220 | T | F950G227MTAAQ2 | 8.8 | 25 | 0.6 | * | |
| | 220 | B | F950G227MBAAQ2 | 8.8 | 16 | 0.4 | * | |
| | 330 | A | F950G337MAAAQ2 | 13.2 | 40 | 0.8 | ±20 | |
| | 330 | T | F950G337MTAAQ2 | 13.2 | 40 | 0.8 | ±20 | |
| | 330 | B | F950G337MBAAQ2 | 13.2 | 30 | 0.6 | ±15 | |
| | 470 | B | F950G477MBAAQ2 | 18.8 | 40 | 0.4 | ±20 | |
| | 6.3V | 22 | R | F950J226MRAAQ2 | 1.4 | 20 | 2.0 | ±20 |
| 33 | | P | F950J336MPAAQ2 | 2.1 | 14 | 1.1 | * | |
| 47 | | P | F950J476MPAAQ2 | 3.0 | 20 | 1.1 | ±15 | |
| 68 | | P | F950J686MPAAQ2 | 4.3 | 25 | 1.2 | ±15 | |
| 100 | | P | F950J107MPAAQ2 | 12.6 | 35 | 1.2 | ±20 | |
| 100 | | Q | F950J107MQAAQ2 | 6.3 | 30 | 1.1 | ±20 | |
| 100 | | S | F950J107MSAAQ2 | 6.3 | 20 | 0.9 | ±15 | |
| 100 | | A | F950J107MAAAQ2 | 6.3 | 14 | 0.5 | * | |
| 100 | | T | F950J107MTAAQ2 | 6.3 | 14 | 0.6 | * | |
| 100 | | B | F950J107MBAAQ2 | 6.3 | 14 | 0.4 | * | |
| 150 | | B | F950J157MBAAQ2 | 9.5 | 18 | 0.4 | * | |
| 220 | | B | F950J227MBAAQ2 | 13.9 | 30 | 0.4 | * | |
| 330 | | B | F950J337MBAAQ2 | 20.8 | 35 | 0.6 | ±20 | |
| 10V | | 10 | R | F951A106MRAAQ2 | 1.0 | 18 | 3.0 | ±20 |
| | | 10 | P | F951A106MPAAQ2 | 1.0 | 8 | 3.0 | * |
| | 15 | P | F951A156MPAAQ2 | 1.5 | 10 | 3.0 | * | |
| | 22 | P | F951A226MPAAQ2 | 2.2 | 14 | 3.0 | * | |
| | 22 | Q | F951A226MQAAQ2 | 2.2 | 10 | 2.0 | * | |
| | 22 | S | F951A226MSAAQ2 | 2.2 | 10 | 1.1 | * | |
| | 22 | A | F951A226MAAAQ2 | 2.2 | 6 | 0.9 | * | |
| | 33 | P | F951A336MPAAQ2 | 3.3 | 20 | 3.0 | ±15 | |
| | 33 | Q | F951A336MQAAQ2 | 3.3 | 18 | 3.0 | ±15 | |
| | 33 | S | F951A336MSAAQ2 | 3.3 | 10 | 1.1 | * | |
| | 33 | A | F951A336MAAAQ2 | 3.3 | 10 | 0.8 | * | |
| | 47 | P | F951A476MPAAQ2 | 4.7 | 30 | 3.0 | ±20 | |
| | 47 | S | F951A476MSAAQ2 | 4.7 | 14 | 1.1 | ±15 | |
| | 47 | A | F951A476MAAAQ2 | 4.7 | 10 | 0.8 | * | |
| | 47 | T | F951A476MTAAQ2 | 4.7 | 12 | 0.8 | * | |
| | 47 | B | F951A476MBAAQ2 | 4.7 | 8 | 0.4 | * | |
| | 68 | B | F951A686MBAAQ2 | 6.8 | 12 | 0.4 | * | |
| | 100 | A | F951A107MAAAQ2 | 10.0 | 35 | 1.0 | ±15 | |
| | 100 | T | F951A107MTAAQ2 | 10.0 | 20 | 0.6 | ±15 | |
| | 100 | B | F951A107MBAAQ2 | 10.0 | 14 | 0.4 | * | |

| Rated Volt | Rated Capacitance (μF) | Case code | Part Number | *2 Leakage Current (μA) | Dissipation Factor (% @ 120Hz) | ESR (Ω @ 100kHz) | *1 ΔC/C (%) |
|------------|------------------------|----------------|----------------|-------------------------|--------------------------------|------------------|-------------|
| 16V | 4.7 | R | F951C475MRAAQ2 | 0.8 | 12 | 6.0 | ±20 |
| | 4.7 | P | F951C475MPAAQ2 | 0.8 | 10 | 4.0 | * |
| | 10 | P | F951C106MPAAQ2 | 1.6 | 10 | 4.0 | * |
| | 10 | Q | F951C106MQAAQ2 | 1.6 | 8 | 3.0 | * |
| | 10 | S | F951C106MSAAQ2 | 1.6 | 8 | 2.0 | * |
| | 10 | A | F951C106MAAAQ2 | 1.6 | 6 | 1.4 | * |
| | 15 | S | F951C156MSAAQ2 | 2.4 | 8 | 2.0 | * |
| | 15 | A | F951C156MAAAQ2 | 2.4 | 8 | 1.4 | * |
| | 22 | Q | F951C226MQAAQ2 | 3.5 | 12 | 3.0 | * |
| | 22 | S | F951C226MSAAQ2 | 3.5 | 10 | 2.0 | ±15 |
| | 22 | A | F951C226MAAAQ2 | 3.5 | 8 | 1.4 | * |
| | 22 | T | F951C226MTAAQ2 | 3.5 | 8 | 1.4 | * |
| | 22 | B | F951C226MBAAQ2 | 3.5 | 6 | 0.5 | * |
| | 33 | T | F951C336MTAAQ2 | 5.3 | 11 | 1.5 | ±10 |
| | 33 | B | F951C336MBAAQ2 | 5.3 | 8 | 0.5 | * |
| 47 | B | F951C476MBAAQ2 | 7.5 | 10 | 0.6 | * | |
| 20V | 2.2 | P | F951D225MPAAQ2 | 0.5 | 6 | 6.0 | * |
| | 4.7 | S | F951D475MSAAQ2 | 0.9 | 8 | 4.0 | * |
| | 4.7 | A | F951D475MAAAQ2 | 0.9 | 6 | 1.5 | * |
| | 10 | S | F951D106MSAAQ2 | 2.0 | 10 | 4.0 | ±10 |
| | 10 | A | F951D106MAAAQ2 | 2.0 | 8 | 1.5 | * |
| | 10 | B | F951D106MBAAQ2 | 2.0 | 6 | 0.8 | * |
| | 22 | B | F951D226MBAAQ2 | 4.4 | 8 | 0.8 | * |
| 25V | 1 | R | F951E105MRAAQ2 | 0.5 | 10 | 10.0 | ±10 |
| | 2.2 | R | F951E225MRAAQ2 | 0.6 | 15 | 15.0 | ±20 |
| | 2.2 | P | F951E225MPAAQ2 | 0.6 | 8 | 6.0 | ±15 |
| | 4.7 | P | F951E475MPAAQ2 | 1.2 | 10 | 8.0 | ±15 |
| | 4.7 | Q | F951E475MQAAQ2 | 1.2 | 10 | 4.0 | ±15 |
| | 4.7 | S | F951E475MSAAQ2 | 1.2 | 8 | 4.0 | * |
| | 4.7 | A | F951E475MAAAQ2 | 1.2 | 8 | 2.0 | * |
| | 10 | A | F951E106MAAAQ2 | 2.5 | 12 | 2.0 | ±15 |
| 10 | B | F951E106MBAAQ2 | 2.5 | 6 | 0.9 | * | |
| 35V | 1 | P | F951V105MPAAQ2 | 0.5 | 8 | 10.0 | ±10 |
| | 1 | S | F951V105MSAAQ2 | 0.5 | 6 | 8.0 | * |
| | 2.2 | A | F951V225MAAAQ2 | 0.8 | 6 | 4.4 | * |
| | 4.7 | B | F951V475MBAAQ2 | 1.7 | 6 | 1.6 | * |

* In case of capacitance tolerance ±10% type, [K] will be put at 9th digit of type numbering system.

1 : ΔC/C Marked ""

| Item | P·Q·S·A·T·B Case (%) |
|---------------------------|----------------------|
| Damp Heat | ±10 |
| Temperature cycles | ±5 |
| Resistance soldering heat | ±5 |
| Surge | ±5 |
| Endurance | ±10 |

*2 : Leakage Current After 1 minute's application of rated voltage, leakage current at 20°C.

TAJ Series



Low Profile



- General purpose SMT chip tantalum series
- CV range: 0.10-1000µF / 2.5-50V
- 10 case sizes in low profile option available



CASE DIMENSIONS: millimeters (inches)

| Code | EIA Code | EIA Metric | L±0.20 (0.008) | W+0.20 (0.008) -0.10 (0.004) | H Max. | W ₁ ±0.20 (0.008) | A+0.30 (0.012) -0.20 (0.008) | S Min. |
|------|----------|------------|----------------|------------------------------|--------------|------------------------------|------------------------------|--------------|
| F | 2312 | 6032-20 | 6.00 (0.236) | 3.20 (0.126) | 2.00 (0.079) | 2.20 (0.087) | 1.30 (0.051) | 2.90 (0.114) |
| H | 1210 | 3528-15 | 3.50 (0.138) | 2.80 (0.110) | 1.50 (0.059) | 2.20 (0.087) | 0.80 (0.031) | 1.40 (0.055) |
| K | 1206 | 3216-10 | 3.20 (0.126) | 1.60 (0.063) | 1.00 (0.039) | 1.20 (0.047) | 0.80 (0.031) | 1.10 (0.043) |
| P | 0805 | 2012-15 | 2.05 (0.081) | 1.35 (0.053) | 1.50 (0.059) | 1.00±0.10 (0.039±0.004) | 0.50 (0.020) | 0.85 (0.033) |
| R | 0805 | 2012-12 | 2.05 (0.081) | 1.30 (0.051) | 1.20 (0.047) | 1.00±0.10 (0.039±0.004) | 0.50 (0.020) | 0.85 (0.033) |
| S | 1206 | 3216-12 | 3.20 (0.126) | 1.60 (0.063) | 1.20 (0.047) | 1.20 (0.047) | 0.80 (0.031) | 1.10 (0.043) |
| T | 1210 | 3528-12 | 3.50 (0.138) | 2.80 (0.110) | 1.20 (0.047) | 2.20 (0.087) | 0.80 (0.031) | 1.40 (0.055) |
| W | 2312 | 6032-15 | 6.00 (0.236) | 3.20 (0.126) | 1.50 (0.059) | 2.20 (0.087) | 1.30 (0.051) | 2.90 (0.114) |
| X | 2917 | 7343-15 | 7.30 (0.287) | 4.30 (0.169) | 1.50 (0.059) | 2.40 (0.094) | 1.30 (0.051) | 4.40 (0.173) |
| Y | 2917 | 7343-20 | 7.30 (0.287) | 4.30 (0.169) | 2.00 (0.079) | 2.40 (0.094) | 1.30 (0.051) | 4.40 (0.173) |

W₁ dimension applies to the termination width for A dimensional area only.

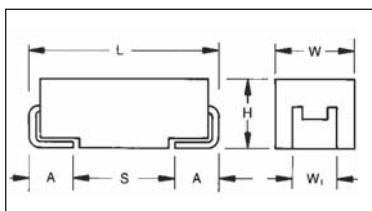

For part marking see page 151

HOW TO ORDER

| | | | | | | | |
|-------------|-------------------------------------|---|--------------------------------------|---|--|---|---|
| TAJ | C | 107 | M | 010 | R | NJ | - |
| Type | Case Size See table above | Capacitance Code pF code: 1st two digits represent significant figures 3rd digit represents multiplier (number of zeros to follow) | Tolerance K=±10% M=±20% | Rated DC Voltage 002=2.5Vdc 004=4Vdc 006=6.3Vdc 010=10Vdc 016=16Vdc 020=20Vdc 025=25Vdc 035=35Vdc 050=50Vdc | Packaging R = Pure Tin 7" Reel S = Pure Tin 13" Reel A = Gold Plating 7" Reel B = Gold Plating 13" Reel | Specification Suffix NJ = Standard Suffix | Additional characters may be added for special requirements V = Dry pack Option (selected codes only) |

TECHNICAL SPECIFICATIONS

| | | | | | | | | | | |
|------------------------------------|--|-----|-----|-----|----|----|----|----|----|----|
| Technical Data: | All technical data relate to an ambient temperature of +25°C | | | | | | | | | |
| Capacitance Range: | 0.10 µF to 1000 µF | | | | | | | | | |
| Capacitance Tolerance: | ±10%; ±20% | | | | | | | | | |
| Rated Voltage (V _R) | ≤ +85°C: | 2.5 | 4 | 6.3 | 10 | 16 | 20 | 25 | 35 | 50 |
| Category Voltage (V _C) | ≤ +125°C: | 1.7 | 2.7 | 4 | 7 | 10 | 13 | 17 | 23 | 33 |
| Surge Voltage (V _S) | ≤ +85°C: | 3.3 | 5.2 | 8 | 13 | 20 | 26 | 32 | 46 | 65 |
| Surge Voltage (V _S) | ≤ +125°C: | 2.2 | 3.4 | 5 | 8 | 13 | 16 | 20 | 28 | 40 |
| Temperature Range: | -55°C to +125°C | | | | | | | | | |
| Reliability: | 1% per 1000 hours at 85°C, V _R with 0.1Ω/V series impedance, 60% confidence level | | | | | | | | | |
| Termination Finished: | Sn Plating (standard), Gold and SnPb Plating upon request | | | | | | | | | |
| | For AEC-Q200 availability, please contact AVX | | | | | | | | | |



CAPACITANCE AND VOLTAGE RANGE, VR (VOLTAGE CODE) RANGE (LETTER DENOTES CASE SIZE)

| Capacitance | | Rated voltage DC (V _R) to 85°C | | | | | | | | |
|-------------|------|--|---------------------------|---------------------------|---------------------------|---------------------|---------|---------|---------|-------------------------|
| µF | Code | 2.5V (e) | 4V (G) | 6.3V (J) | 10V (A) | 16V (C) | 20V (D) | 25V (E) | 35V (V) | 50V (T) |
| 0.10 | 104 | | | | | | R/S | | R/S | S |
| 0.15 | 154 | | | | | | R/S | R | R/S | S |
| 0.22 | 224 | | | | | | R/S | R | R/S | P/R/S |
| 0.33 | 334 | | | | | | R/S | R | R/S | P/R ^(M) /S/T |
| 0.47 | 474 | | | | | | R/S | R/S | R/S/T | S/T |
| 0.68 | 684 | | | | | R/S | R/S/T | R/S | P/S/T | |
| 1.0 | 105 | | | | R/S | R/S/T | R/S/T | P/R/S | P/S/T | W |
| 1.5 | 155 | | | R/S | R/S | R/S | P/R/S/T | P/S/T | T | W |
| 2.2 | 225 | | R/S | R/S | R/S | R/S/T | P/R/S/T | T | T | |
| 3.3 | 335 | | R/S | R/S | R/S/T | R/S/T | T | T/W | W | Y |
| 4.7 | 475 | R | R/S | R/S/T | R/S/T | K/P/S/T | T | T/W | W | Y |
| 6.8 | 685 | R | R/S/T | R/S/T | P/R/S/T | S/T | T | W | Y | Y |
| 10 | 106 | R/S | R/S/T | P/R/S/T | K/P/R ^(M) /S/T | T/W | W | W | X/Y | |
| 15 | 156 | R | R/S/T | K/P/R/S/T | S/T/W | T ^(M) /W | W | Y | Y | |
| 22 | 226 | P/R | K/P/R/S/T | K/P ^(M) /S/T/W | T/W | W | W/Y | Y | Y | |
| 33 | 336 | K/P/S | K/P ^(M) /S/T/W | T/W | W | W/Y | X/Y | Y | | |
| 47 | 476 | P ^(M) /S | T/W | T/W | H/W/Y | W/X/Y | X/Y | Y | | |
| 68 | 686 | T | T/W | W | W/Y | F/X/Y | Y | | | |
| 100 | 107 | T/W | T ^(M) /W | W/Y | W/X/Y | F ^(M) /Y | | | | |
| 150 | 157 | T ^(M) /W | W/Y | W/X/Y | F/X ^(M) /Y | Y ^(M) | | | | |
| 220 | 227 | W/Y | W/X/Y | F/X/Y | Y | | | | | |
| 330 | 337 | W ^(M) /Y | F/X/Y | Y | | | | | | |
| 470 | 477 | F/Y | Y | Y | | | | | | |
| 680 | 687 | Y | Y ^(M) | | | | | | | |
| 1000 | 108 | Y ^(M) | | | | | | | | |

Released codes ^(M tolerance only)

Engineering samples - please contact manufacturer

*Codes under development - subject to change

Note: Voltage ratings are minimum values. AVX reserves the right to supply higher ratings in the same case size, to the same reliability standards.

TAJ Series

Low Profile



RATINGS & PART NUMBER REFERENCE

| AVX Part No. | Case Size | Cap (µF) | Rated Voltage (V) | DCL (µA) Max. | DF % Max. | ESR Max. (Ω) @100kHz | MSL |
|---|-----------|----------|-------------------|---------------|-----------|----------------------|-----------------|
| 2.5 Volt @ 85°C (1.7 Volt @ 125°C) | | | | | | | |
| TAJR475*002#NJ | R | 4.7 | 2.5 | 0.5 | 6 | 20 | 1 |
| TAJR685*002#NJ | R | 6.8 | 2.5 | 0.5 | 6 | 20 | 1 |
| TAJR106*002#NJ | R | 10 | 2.5 | 0.5 | 8 | 4.5 | 1 |
| TAJS106*002#NJ | S | 10 | 2.5 | 0.5 | 6 | 8 | 1 |
| TAJR156*002#NJ | R | 15 | 2.5 | 0.5 | 8 | 4.1 | 1 |
| TAJP226*002#NJ | P | 22 | 2.5 | 0.5 | 8 | 3.5 | 1 |
| TAJR226*002#NJ | R | 22 | 2.5 | 0.5 | 8 | 3.8 | 1 |
| TAJK336*002#NJ | K | 33 | 2.5 | 0.8 | 8 | 1.7 | 1 |
| TAJP336*002#NJ | P | 33 | 2.5 | 0.7 | 8 | 3.5 | 1 |
| TAJS336*002#NJ | S | 33 | 2.5 | 0.7 | 8 | 1.5 | 1 |
| TAJP476M002#NJ | P | 47 | 2.5 | 1.2 | 12 | 3.2 | 1 |
| TAJS476*002#NJ | S | 47 | 2.5 | 1.2 | 8 | 1.6 | 1 |
| TAJT686*002#NJ | T | 68 | 2.5 | 1.4 | 8 | 1.5 | 1 |
| TAJT107*002#NJ | T | 100 | 2.5 | 2.5 | 15 | 1.3 | 1 |
| TAJW107*002#NJ | W | 100 | 2.5 | 2.5 | 8 | 0.4 | 1 |
| TAJT157M002#NJ | T | 150 | 2.5 | 3.8 | 18 | 1.2 | 1 |
| TAJW157*002#NJ | W | 150 | 2.5 | 3.8 | 8 | 0.3 | 1 |
| TAJW227*002#NJ | W | 220 | 2.5 | 5.5 | 8 | 0.3 | 1 |
| TAJY227*002#NJ | Y | 220 | 2.5 | 5.5 | 8 | 0.3 | 1 ¹⁾ |
| TAJW337M002#NJ | W | 330 | 2.5 | 8.2 | 12 | 0.3 | 1 |
| TAJY337*002#NJ | Y | 330 | 2.5 | 8.2 | 8 | 0.3 | 1 ¹⁾ |
| TAJF477*002#NJ | F | 470 | 2.5 | 11.8 | 12 | 0.3 | 1 |
| TAJY477*002#NJ | Y | 470 | 2.5 | 11 | 12 | 0.2 | 1 ¹⁾ |
| TAJY687*002#NJ | Y | 680 | 2.5 | 17 | 12 | 0.2 | 1 ¹⁾ |
| TAJY108M002#NJ | Y | 1000 | 2.5 | 25 | 30 | 0.2 | 1 ¹⁾ |
| 4 Volt @ 85°C (2.7 Volt @ 125°C) | | | | | | | |
| TAJR225*004#NJ | R | 2.2 | 4 | 0.5 | 6 | 25 | 1 |
| TAJS225*004#NJ | S | 2.2 | 4 | 0.5 | 6 | 25 | 1 |
| TAJR335*004#NJ | R | 3.3 | 4 | 0.5 | 6 | 20 | 1 |
| TAJS335*004#NJ | S | 3.3 | 4 | 0.5 | 6 | 18 | 1 |
| TAJR475*004#NJ | R | 4.7 | 4 | 0.5 | 6 | 12 | 1 |
| TAJS475*004#NJ | S | 4.7 | 4 | 0.5 | 6 | 10 | 1 |
| TAJR685*004#NJ | R | 6.8 | 4 | 0.5 | 6 | 5.2 | 1 |
| TAJS685*004#NJ | S | 6.8 | 4 | 0.5 | 6 | 8 | 1 |
| TAJT685*004#NJ | T | 6.8 | 4 | 0.5 | 6 | 6 | 1 |
| TAJR106*004#NJ | R | 10 | 4 | 0.5 | 6 | 7 | 1 |
| TAJS106*004#NJ | S | 10 | 4 | 0.5 | 6 | 6 | 1 |
| TAJT106*004#NJ | T | 10 | 4 | 0.5 | 6 | 5 | 1 |
| TAJR156*004#NJ | R | 15 | 4 | 0.6 | 8 | 4 | 1 |
| TAJS156*004#NJ | S | 15 | 4 | 0.6 | 8 | 4 | 1 |
| TAJT156*004#NJ | T | 15 | 4 | 0.6 | 6 | 2 | 1 |
| TAJK226*004#NJ | K | 22 | 4 | 0.9 | 8 | 1.8 | 1 |
| TAJP226*004#NJ | P | 22 | 4 | 0.9 | 8 | 4 | 1 |
| TAJR226*004#NJ | R | 22 | 4 | 0.9 | 8 | 3.8 | 1 |
| TAJS226*004#NJ | S | 22 | 4 | 0.9 | 8 | 3.5 | 1 |
| TAJT226*004#NJ | T | 22 | 4 | 0.9 | 6 | 1.9 | 1 |
| TAJK336*004#NJ | K | 33 | 4 | 1.3 | 10 | 1.7 | 1 |
| TAJP336M004#NJ | P | 33 | 4 | 1.3 | 8 | 2.8 | 1 |
| TAJS336*004#NJ | S | 33 | 4 | 1.3 | 8 | 1.7 | 1 |
| TAJT336*004#NJ | T | 33 | 4 | 1.3 | 6 | 1.7 | 1 |
| TAJW336*004#NJ | W | 33 | 4 | 1.3 | 6 | 0.6 | 1 |
| TAJT476*004#NJ | T | 47 | 4 | 1.9 | 10 | 1.6 | 1 |
| TAJW476*004#NJ | W | 47 | 4 | 1.9 | 6 | 0.5 | 1 |
| TAJT686*004#NJ | T | 68 | 4 | 2.7 | 15 | 1.5 | 1 |
| TAJW686*004#NJ | W | 68 | 4 | 2.7 | 6 | 0.4 | 1 |
| TAJT107M004#NJ | T | 100 | 4 | 4 | 14 | 1.4 | 1 |
| TAJW107*004#NJ | W | 100 | 4 | 4 | 6 | 0.4 | 1 |
| TAJW157*004#NJ | W | 150 | 4 | 6 | 6 | 0.5 | 1 |
| TAJY157*004#NJ | Y | 150 | 4 | 6 | 6 | 0.4 | 1 ¹⁾ |
| TAJW227*004#NJ | W | 220 | 4 | 8.8 | 8 | 0.3 | 1 |
| TAJX227*004#NJ | X | 220 | 4 | 8.8 | 8 | 0.9 | 1 ¹⁾ |
| TAJY227*004#NJ | Y | 220 | 4 | 8.8 | 8 | 0.3 | 1 ¹⁾ |
| TAJF337*004#NJ | F | 330 | 4 | 13.2 | 10 | 0.3 | 1 |
| TAJX337*004#NJ | X | 330 | 4 | 13.2 | 8 | 0.3 | 1 ¹⁾ |

| AVX Part No. | Case Size | Cap (µF) | Rated Voltage (V) | DCL (µA) Max. | DF % Max. | ESR Max. (Ω) @100kHz | MSL |
|---|-----------|----------|-------------------|---------------|-----------|----------------------|-----------------|
| TAJY337*004#NJ | Y | 330 | 4 | 13.2 | 12 | 0.4 | 1 ¹⁾ |
| TAJY477*004#NJ | Y | 470 | 4 | 18.8 | 14 | 0.4 | 1 ¹⁾ |
| TAJY687M004#NJ | Y | 680 | 4 | 27.2 | 25 | 0.2 | 1 ¹⁾ |
| 6.3 Volt @ 85°C (4 Volt @ 125°C) | | | | | | | |
| TAJR155*006#NJ | R | 1.5 | 6.3 | 0.5 | 6 | 25 | 1 |
| TAJS155*006#NJ | S | 1.5 | 6.3 | 0.5 | 6 | 25 | 1 |
| TAJR225*006#NJ | R | 2.2 | 6.3 | 0.5 | 6 | 20 | 1 |
| TAJS225*006#NJ | S | 2.2 | 6.3 | 0.5 | 6 | 18 | 1 |
| TAJR335*006#NJ | R | 3.3 | 6.3 | 0.5 | 6 | 12 | 1 |
| TAJS335*006#NJ | S | 3.3 | 6.3 | 0.5 | 6 | 9 | 1 |
| TAJR475*006#NJ | R | 4.7 | 6.3 | 0.5 | 6 | 7 | 1 |
| TAJS475*006#NJ | S | 4.7 | 6.3 | 0.5 | 6 | 7.5 | 1 |
| TAJT475*006#NJ | T | 4.7 | 6.3 | 0.5 | 6 | 6 | 1 |
| TAJR685*006#NJ | R | 6.8 | 6.3 | 0.5 | 8 | 7 | 1 |
| TAJS685*006#NJ | S | 6.8 | 6.3 | 0.5 | 6 | 2.6 | 1 |
| TAJT685*006#NJ | T | 6.8 | 6.3 | 0.5 | 6 | 5 | 1 |
| TAJP106*006#NJ | P | 10 | 6.3 | 0.6 | 8 | 6 | 1 |
| TAJR106*006#NJ | R | 10 | 6.3 | 0.6 | 8 | 6 | 1 |
| TAJS106*006#NJ | S | 10 | 6.3 | 0.6 | 8 | 4 | 1 |
| TAJT106*006#NJ | T | 10 | 6.3 | 0.6 | 6 | 4 | 1 |
| TAJK156*006#NJ | K | 15 | 6.3 | 0.9 | 6 | 2 | 1 |
| TAJP156*006#NJ | P | 15 | 6.3 | 0.9 | 8 | 3.5 | 1 |
| TAJR156*006#NJ | R | 15 | 6.3 | 0.9 | 8 | 4.1 | 1 |
| TAJS156*006#NJ | S | 15 | 6.3 | 0.9 | 8 | 3.5 | 1 |
| TAJT156*006#NJ | T | 15 | 6.3 | 0.9 | 6 | 3.5 | 1 |
| TAJK226*006#NJ | K | 22 | 6.3 | 1.3 | 10 | 1.8 | 1 |
| TAJP226M006#NJ | P | 22 | 6.3 | 1.3 | 8 | 3.3 | 1 |
| TAJS226*006#NJ | S | 22 | 6.3 | 1.3 | 10 | 1.8 | 1 |
| TAJT226*006#NJ | T | 22 | 6.3 | 1.4 | 8 | 2.5 | 1 |
| TAJW226*006#NJ | W | 22 | 6.3 | 1.3 | 6 | 0.6 | 1 |
| TAJT336*006#NJ | T | 33 | 6.3 | 2.1 | 10 | 2.5 | 1 |
| TAJW336*006#NJ | W | 33 | 6.3 | 2 | 6 | 0.5 | 1 |
| TAJT476*006#NJ | T | 47 | 6.3 | 2.8 | 10 | 1.6 | 1 |
| TAJW476*006#NJ | W | 47 | 6.3 | 2.8 | 6 | 0.5 | 1 |
| TAJW686*006#NJ | W | 68 | 6.3 | 4.3 | 6 | 1.5 | 1 |
| TAJW107*006#NJ | W | 100 | 6.3 | 6.3 | 6 | 0.9 | 1 |
| TAJY107*006#NJ | Y | 100 | 6.3 | 6.3 | 6 | 0.7 | 1 ¹⁾ |
| TAJW157*006#NJ | W | 150 | 6.3 | 9 | 8 | 0.3 | 1 |
| TAJT157*006#NJ | X | 150 | 6.3 | 9 | 6 | 0.4 | 1 ¹⁾ |
| TAJY157*006#NJ | Y | 150 | 6.3 | 9.5 | 6 | 0.4 | 1 ¹⁾ |
| TAJF227*006#NJ | F | 220 | 6.3 | 13.2 | 10 | 0.3 | 1 |
| TAJX227*006#NJ | X | 220 | 6.3 | 13.2 | 8 | 0.3 | 1 ¹⁾ |
| TAJY227*006#NJ | Y | 220 | 6.3 | 13.9 | 8 | 0.7 | 1 ¹⁾ |
| TAJY337*006#NJ | Y | 330 | 6.3 | 20.8 | 12 | 0.4 | 1 ¹⁾ |
| TAJY477*006#NJ | Y | 470 | 6.3 | 28.2 | 20 | 0.2 | 1 ¹⁾ |
| 10 Volt @ 85°C (7 Volt @ 125°C) | | | | | | | |
| TAJR105*010#NJ | R | 1 | 10 | 0.5 | 4 | 25 | 1 |
| TAJS105*010#NJ | S | 1 | 10 | 0.5 | 4 | 25 | 1 |
| TAJR155*010#NJ | R | 1.5 | 10 | 0.5 | 6 | 20 | 1 |
| TAJS155*010#NJ | S | 1.5 | 10 | 0.5 | 6 | 20 | 1 |
| TAJR225*010#NJ | R | 2.2 | 10 | 0.5 | 6 | 15 | 1 |
| TAJS225*010#NJ | S | 2.2 | 10 | 0.5 | 6 | 12 | 1 |
| TAJR335*010#NJ | R | 3.3 | 10 | 0.5 | 6 | 8 | 1 |
| TAJS335*010#NJ | S | 3.3 | 10 | 0.5 | 6 | 8 | 1 |
| TAJT335*010#NJ | T | 3.3 | 10 | 0.5 | 6 | 6 | 1 |
| TAJR475*010#NJ | R | 4.7 | 10 | 0.5 | 6 | 9 | 1 |
| TAJS475*010#NJ | S | 4.7 | 10 | 0.5 | 6 | 5 | 1 |
| TAJT475*010#NJ | T | 4.7 | 10 | 0.5 | 6 | 5 | 1 |
| TAJP685*010#NJ | P | 6.8 | 10 | 0.6 | 6 | 5 | 1 |
| TAJR685*010#NJ | R | 6.8 | 10 | 0.7 | 6 | 5.2 | 1 |
| TAJS685*010#NJ | S | 6.8 | 10 | 0.7 | 6 | 4 | 1 |
| TAJT685*010#NJ | T | 6.8 | 10 | 0.7 | 6 | 4 | 1 |
| TAJK106*010#NJ | K | 10 | 10 | 1 | 6 | 2.2 | 1 |
| TAJP106*010#NJ | P | 10 | 10 | 1 | 8 | 6 | 1 |
| TAJR106M010#NJ | R | 10 | 10 | 1 | 20 | 6 | 1 |

1¹⁾ Dry pack option (see How to order) recommended for reduction of stress during soldering. Dry pack parts should be treated as MSL 3.

Moisture Sensitivity Level (MSL) is defined according to J-STD-020.

All technical data relates to an ambient temperature of +25°C. Capacitance and DF are measured at 120Hz, 0.5V RMS with a maximum DC bias of 2.2 volts. DCL is measured at rated voltage after 5 minutes.

For typical weight and composition see page 144.

NOTE: AVX reserves the right to supply a higher voltage rating or tighter tolerance part in the same case size, to the same reliability standards.



Low Profile

RATINGS & PART NUMBER REFERENCE

| AVX Part No. | Case Size | Cap (µF) | Rated Voltage (V) | DCL (µA) Max. | DF % Max. | ESR Max. (Ω) @100kHz | MSL |
|---|-----------|----------|-------------------|---------------|-----------|----------------------|-----------------|
| TAJS106*010#NJ | S | 10 | 10 | 1 | 8 | 3 | 1 |
| TAJT106*010#NJ | T | 10 | 10 | 1 | 6 | 3 | 1 |
| TAJS156*010#NJ | S | 15 | 10 | 1.5 | 6 | 2 | 1 |
| TAJT156*010#NJ | T | 15 | 10 | 1.5 | 8 | 2.8 | 1 |
| TAJW156*010#NJ | W | 15 | 10 | 1.5 | 6 | 0.7 | 1 |
| TAJT226*010#NJ | T | 22 | 10 | 2.2 | 8 | 2.2 | 1 |
| TAJW226*010#NJ | W | 22 | 10 | 2.2 | 6 | 0.6 | 1 |
| TAJW336*010#NJ | W | 33 | 10 | 3.3 | 6 | 1.6 | 1 |
| TAJH476*006#NJ | H | 47 | 10 | 4.7 | 8 | 1.0 | 1 |
| TAJW476*010#NJ | W | 47 | 10 | 4.7 | 6 | 1.4 | 1 |
| TAJY476*010#NJ | Y | 47 | 10 | 4.7 | 6 | 0.5 | 1 ¹⁾ |
| TAJW686*010#NJ | W | 68 | 10 | 6.8 | 6 | 1.2 | 1 |
| TAJY686*010#NJ | Y | 68 | 10 | 6.8 | 6 | 0.9 | 1 ¹⁾ |
| TAJW107*010#NJ | W | 100 | 10 | 10 | 6 | 0.4 | 1 |
| TAJX107*010#NJ | X | 100 | 10 | 10 | 8 | 0.9 | 1 ¹⁾ |
| TAJY107*010#NJ | Y | 100 | 10 | 10 | 6 | 0.9 | 1 ¹⁾ |
| TAJF157*010#NJ | F | 150 | 10 | 15 | 10 | 0.3 | 1 |
| TAJX157M010#NJ | X | 150 | 10 | 15 | 6 | 0.3 | 1 ¹⁾ |
| TAJY157*010#NJ | Y | 150 | 10 | 15 | 6 | 1.2 | 1 ¹⁾ |
| TAJY227*010#NJ | Y | 220 | 10 | 22 | 10 | 0.5 | 1 ¹⁾ |
| 16 Volt @ 85°C (10 Volt @ 125°C) | | | | | | | |
| TAJR684*016#NJ | R | 0.68 | 16 | 0.5 | 4 | 25 | 1 |
| TAJS684*016#NJ | S | 0.68 | 16 | 0.5 | 4 | 25 | 1 |
| TAJR105*016#NJ | R | 1 | 16 | 0.5 | 4 | 20 | 1 |
| TAJS105*016#NJ | S | 1 | 16 | 0.5 | 4 | 15 | 1 |
| TAJT105*016#NJ | T | 1 | 16 | 0.5 | 4 | 5 | 1 |
| TAJR155*016#NJ | R | 1.5 | 16 | 0.5 | 6 | 10 | 1 |
| TAJS155*016#NJ | S | 1.5 | 16 | 0.5 | 6 | 12 | 1 |
| TAJR225*016#NJ | R | 2.2 | 16 | 0.5 | 6 | 6.5 | 1 |
| TAJS225*016#NJ | S | 2.2 | 16 | 0.5 | 6 | 6 | 1 |
| TAJT225*016#NJ | T | 2.2 | 16 | 0.5 | 6 | 6.5 | 1 |
| TAJR335*016#NJ | R | 3.3 | 16 | 0.5 | 8 | 5 | 1 |
| TAJS335*016#NJ | S | 3.3 | 16 | 0.5 | 6 | 5 | 1 |
| TAJT335*016#NJ | T | 3.3 | 16 | 0.5 | 6 | 5 | 1 |
| TAJK475*016#NJ | K | 4.7 | 16 | 0.8 | 6 | 3.1 | 1 |
| TAJP475*016#NJ | P | 4.7 | 16 | 0.8 | 8 | 5 | 1 |
| TAJ475*016#NJ | S | 4.7 | 16 | 0.8 | 8 | 4 | 1 |
| TAJT475*016#NJ | T | 4.7 | 16 | 0.8 | 6 | 3.1 | 1 |
| TAJS685*016#NJ | S | 6.8 | 16 | 1.1 | 8 | 2.4 | 1 |
| TAJT685*016#NJ | T | 6.8 | 16 | 1.1 | 6 | 3.5 | 1 |
| TAJT106*016#NJ | T | 10 | 16 | 1.6 | 8 | 2.2 | 1 |
| TAJW106*016#NJ | W | 10 | 16 | 1.6 | 6 | 2 | 1 |
| TAJT156M016#NJ | T | 15 | 16 | 2.4 | 6 | 2 | 1 |
| TAJW156*016#NJ | W | 15 | 16 | 2.4 | 6 | 0.7 | 1 |
| TAJW226*016#NJ | W | 22 | 16 | 3.5 | 6 | 1.6 | 1 |
| TAJW336*016#NJ | W | 33 | 16 | 5.3 | 6 | 1.5 | 1 |
| TAJY336*016#NJ | Y | 33 | 16 | 5.3 | 6 | 0.9 | 1 ¹⁾ |
| TAJW476*016#NJ | W | 47 | 16 | 7.5 | 6 | 0.4 | 1 |
| TAJX476*016#NJ | X | 47 | 16 | 7.5 | 6 | 0.75 | 1 ¹⁾ |
| TAJY476*016#NJ | Y | 47 | 16 | 7.5 | 6 | 0.7 | 1 ¹⁾ |
| TAJF686*016#NJ | F | 68 | 16 | 10.9 | 10 | 0.4 | 1 |
| TAJX686*016#NJ | X | 68 | 16 | 10.9 | 8 | 0.6 | 1 ¹⁾ |
| TAJY686*016#NJ | Y | 68 | 16 | 10.9 | 6 | 0.9 | 1 ¹⁾ |
| TAJF107M016#NJ | F | 100 | 16 | 16 | 10 | 0.4 | 1 |
| TAJY107*016#NJ | Y | 100 | 16 | 16 | 8 | 0.9 | 1 ¹⁾ |
| TAJY157M016#NJ | Y | 150 | 16 | 24 | 15 | 0.3 | 1 ¹⁾ |
| 20 Volt @ 85°C (13 Volt @ 125°C) | | | | | | | |
| TAJR104*020#NJ | R | 0.1 | 20 | 0.5 | 4 | 25 | 1 |
| TAJS104*020#NJ | S | 0.1 | 20 | 0.5 | 4 | 25 | 1 |
| TAJR154*020#NJ | R | 0.15 | 20 | 0.5 | 4 | 25 | 1 |
| TAJS154*020#NJ | S | 0.15 | 20 | 0.5 | 4 | 25 | 1 |
| TAJR224*020#NJ | R | 0.22 | 20 | 0.5 | 4 | 25 | 1 |
| TAJS224*020#NJ | S | 0.22 | 20 | 0.5 | 4 | 25 | 1 |
| TAJR334*020#NJ | R | 0.33 | 20 | 0.5 | 4 | 25 | 1 |
| TAJS334*020#NJ | S | 0.33 | 20 | 0.5 | 4 | 25 | 1 |

| AVX Part No. | Case Size | Cap (µF) | Rated Voltage (V) | DCL (µA) Max. | DF % Max. | ESR Max. (Ω) @100kHz | MSL |
|---|-----------|----------|-------------------|---------------|-----------|----------------------|-----------------|
| TAJR474*020#NJ | R | 0.47 | 20 | 0.5 | 4 | 25 | 1 |
| TAJS474*020#NJ | S | 0.47 | 20 | 0.5 | 4 | 25 | 1 |
| TAJR684*020#NJ | R | 0.68 | 20 | 0.5 | 4 | 20 | 1 |
| TAJS684*020#NJ | S | 0.68 | 20 | 0.5 | 4 | 25 | 1 |
| TAJT684*020#NJ | T | 0.68 | 20 | 0.5 | 4 | 15 | 1 |
| TAJR105*020#NJ | R | 1 | 20 | 0.5 | 4 | 20 | 1 |
| TAJS105*020#NJ | S | 1 | 20 | 0.5 | 4 | 12 | 1 |
| TAJT105*020#NJ | T | 1 | 20 | 0.5 | 4 | 9 | 1 |
| TAJP155*020#NJ | P | 1.5 | 20 | 0.5 | 6 | 9.6 | 1 |
| TAJR155*020#NJ | R | 1.5 | 20 | 0.5 | 6 | 9.6 | 1 |
| TAJS155*020#NJ | S | 1.5 | 20 | 0.5 | 6 | 5.4 | 1 |
| TAJT155*020#NJ | T | 1.5 | 20 | 0.5 | 6 | 6.5 | 1 |
| TAJP225*020#NJ | P | 2.2 | 20 | 0.5 | 6 | 8.3 | 1 |
| TAJR225*020#NJ | R | 2.2 | 20 | 0.5 | 6 | 6 | 1 |
| TAJS225*020#NJ | S | 2.2 | 20 | 0.5 | 6 | 4.5 | 1 |
| TAJT225*020#NJ | T | 2.2 | 20 | 0.5 | 6 | 6 | 1 |
| TAJT335*020#NJ | T | 3.3 | 20 | 0.7 | 6 | 3 | 1 |
| TAJT475*020#NJ | T | 4.7 | 20 | 0.9 | 6 | 3.1 | 1 |
| TAJT685*020#NJ | T | 6.8 | 20 | 1.4 | 6 | 2.6 | 1 |
| TAJW106*020#NJ | W | 10 | 20 | 2 | 6 | 1.9 | 1 |
| TAJW156*020#NJ | W | 15 | 20 | 3 | 6 | 1.7 | 1 |
| TAJW226*020#NJ | W | 22 | 20 | 4.4 | 6 | 1.6 | 1 |
| TAJY226*020#NJ | Y | 22 | 20 | 4.4 | 6 | 0.9 | 1 ¹⁾ |
| TAJX336*020#NJ | X | 33 | 20 | 6.6 | 6 | 0.5 | 1 ¹⁾ |
| TAJY336*020#NJ | Y | 33 | 20 | 6.6 | 6 | 0.6 | 1 ¹⁾ |
| TAJX476*020#NJ | X | 47 | 20 | 9.4 | 6 | 0.4 | 1 ¹⁾ |
| TAJY476*020#NJ | Y | 47 | 20 | 9.4 | 6 | 0.9 | 1 ¹⁾ |
| TAJY686*020#NJ | Y | 68 | 20 | 13.6 | 6 | 0.9 | 1 ¹⁾ |
| 25 Volt @ 85°C (17 Volt @ 125°C) | | | | | | | |
| TAJR154*025#NJ | R | 0.15 | 25 | 0.5 | 4 | 24 | 1 |
| TAJR224*025#NJ | R | 0.22 | 25 | 0.5 | 4 | 21 | 1 |
| TAJR334*025#NJ | R | 0.33 | 25 | 0.5 | 4 | 17 | 1 |
| TAJR474*025#NJ | R | 0.47 | 25 | 0.5 | 4 | 15 | 1 |
| TAJS474*025#NJ | S | 0.47 | 25 | 0.5 | 4 | 9 | 1 |
| TAJR684*025#NJ | R | 0.68 | 25 | 0.5 | 4 | 13 | 1 |
| TAJS684*025#NJ | S | 0.68 | 25 | 0.5 | 4 | 8 | 1 |
| TAJP105*025#NJ | P | 1 | 25 | 0.5 | 4 | 11 | 1 |
| TAJR105*025#NJ | R | 1 | 25 | 0.5 | 4 | 8 | 1 |
| TAJS105*025#NJ | S | 1 | 25 | 0.5 | 4 | 8 | 1 |
| TAJP155*025#NJ | P | 1.5 | 25 | 0.5 | 6 | 9.6 | 1 |
| TAJS155*025#NJ | S | 1.5 | 25 | 0.5 | 6 | 5.4 | 1 |
| TAJT155*025#NJ | T | 1.5 | 25 | 0.5 | 6 | 5 | 1 |
| TAJT225*025#NJ | T | 2.2 | 25 | 0.6 | 6 | 4.5 | 1 |
| TAJT335*025#NJ | T | 3.3 | 25 | 0.8 | 6 | 3.5 | 1 |
| TAJW335*025#NJ | W | 3.3 | 25 | 0.8 | 6 | 1.6 | 1 |
| TAJT475*025#NJ | T | 4.7 | 25 | 1.2 | 6 | 3.1 | 1 |
| TAJW475*025#NJ | W | 4.7 | 25 | 1.2 | 6 | 1.2 | 1 |
| TAJW685*025#NJ | W | 6.8 | 25 | 1.7 | 6 | 2 | 1 |
| TAJW106*025#NJ | W | 10 | 25 | 2.5 | 6 | 1.8 | 1 |
| TAJY156*025#NJ | Y | 15 | 25 | 3.8 | 6 | 1 | 1 ¹⁾ |
| TAJY226*025#NJ | Y | 22 | 25 | 5.5 | 6 | 0.8 | 1 ¹⁾ |
| TAJY336*025#NJ | Y | 33 | 25 | 8.3 | 6 | 0.5 | 1 ¹⁾ |
| TAJY476*025#NJ | Y | 47 | 25 | 11.8 | 6 | 0.9 | 1 ¹⁾ |
| 35 Volt @ 85°C (23 Volt @ 125°C) | | | | | | | |
| TAJR104*035#NJ | R | 0.1 | 35 | 0.5 | 4 | 29 | 1 |
| TAJS104*035#NJ | S | 0.1 | 35 | 0.5 | 4 | 24 | 1 |
| TAJR154*035#NJ | R | 0.15 | 35 | 0.5 | 4 | 24 | 1 |
| TAJS154*035#NJ | S | 0.15 | 35 | 0.5 | 4 | 21 | 1 |
| TAJR224*035#NJ | R | 0.22 | 35 | 0.5 | 4 | 21 | 1 |
| TAJS224*035#NJ | S | 0.22 | 35 | 0.5 | 4 | 18 | 1 |
| TAJR334*035#NJ | R | 0.33 | 35 | 0.5 | 4 | 17 | 1 |
| TAJS334*035#NJ | S | 0.33 | 35 | 0.5 | 4 | 15 | 1 |
| TAJR474*035#NJ | R | 0.47 | 35 | 0.5 | 4 | 15 | 1 |
| TAJS474*035#NJ | S | 0.47 | 35 | 0.5 | 4 | 12 | 1 |
| TAJT474*035#NJ | T | 0.47 | 35 | 0.5 | 4 | 10 | 1 |

¹⁾ Dry pack option (see How to order) recommended for reduction of stress during soldering. Dry pack parts should be treated as MSL 3.

Moisture Sensitivity Level (MSL) is defined according to J-STD-020.

All technical data relates to an ambient temperature of +25°C. Capacitance and DF are measured at 120Hz, 0.5V RMS with a maximum DC bias of 2.2 volts. DCL is measured at rated voltage after 5 minutes.

For typical weight and composition see page 144.

NOTE: AVX reserves the right to supply a higher voltage rating or tighter tolerance part in the same case size, to the same reliability standards.

RATINGS & PART NUMBER REFERENCE

| AVX Part No. | Case Size | Cap (µF) | Rated Voltage (V) | DCL (µA) Max. | DF % Max. | ESR Max. (Ω) @100kHz | MSL |
|---|-----------|----------|-------------------|---------------|-----------|----------------------|-----------------|
| TAJP684*035#NJ | P | 0.68 | 35 | 0.5 | 4 | 13 | 1 |
| TAJS684*035#NJ | S | 0.68 | 35 | 0.5 | 4 | 8 | 1 |
| TAJT684*035#NJ | T | 0.68 | 35 | 0.5 | 4 | 8 | 1 |
| TAJP105*035#NJ | P | 1 | 35 | 0.5 | 4 | 11 | 1 |
| TAJS105*035#NJ | S | 1 | 35 | 0.5 | 4 | 7.5 | 1 |
| TAJT105*035#NJ | T | 1 | 35 | 5 | 4 | 6.5 | 1 |
| TAJT155*035#NJ | T | 1.5 | 35 | 0.5 | 6 | 5.2 | 1 |
| TAJT225*035#NJ | T | 2.2 | 35 | 0.8 | 6 | 4.2 | 1 |
| TAJW335*035#NJ | W | 3.3 | 35 | 1.2 | 6 | 1.6 | 1 |
| TAJW475*035#NJ | W | 4.7 | 35 | 1.6 | 6 | 2.2 | 1 |
| TAJY685*035#NJ | Y | 6.8 | 35 | 2.3 | 6 | 0.9 | 1 ¹⁾ |
| TAJX106*035#NJ | X | 10 | 35 | 3.5 | 6 | 0.7 | 1 ¹⁾ |
| TAJY106*035#NJ | Y | 10 | 35 | 3.5 | 6 | 1 | 1 ¹⁾ |
| TAJY156*035#NJ | Y | 15 | 35 | 5.3 | 6 | 0.6 | 1 ¹⁾ |
| TAJY226*035#NJ | Y | 22 | 35 | 7.7 | 6 | 0.5 | 1 ¹⁾ |
| 50 Volt @ 85°C (33 Volt @ 125°C) | | | | | | | |
| TAJS104*050#NJ | S | 0.1 | 50 | 0.5 | 4 | 19 | 1 |
| TAJS154*050#NJ | S | 0.15 | 50 | 0.5 | 4 | 16 | 1 |
| TAJP224*050#NJ | P | 0.22 | 50 | 0.5 | 4 | 17 | 1 |
| TAJR224*050#NJ | R | 0.22 | 50 | 0.5 | 4 | 17 | 1 |
| TAJS224*050#NJ | S | 0.22 | 50 | 0.5 | 4 | 13 | 1 |
| TAJP334*050#NJ | P | 0.33 | 50 | 0.5 | 4 | 17 | 1 |
| TAJR334M050#NJ | R | 0.33 | 50 | 0.5 | 4 | 17 | 1 |
| TAJS334*050#NJ | S | 0.33 | 50 | 0.5 | 4 | 11 | 1 |
| TAJT334*050#NJ | T | 0.33 | 50 | 0.5 | 4 | 11 | 1 |
| TAJS474*050#NJ | S | 0.47 | 50 | 0.5 | 4 | 9.5 | 1 |
| TAJT474*050#NJ | T | 0.47 | 50 | 0.5 | 4 | 9.5 | 1 |
| TAJW105*050#NJ | W | 1 | 50 | 0.5 | 6 | 4.4 | 1 |
| TAJW155*050#NJ | W | 1.5 | 50 | 0.8 | 6 | 3.1 | 1 |
| TAJY335*050#NJ | Y | 3.3 | 50 | 1.7 | 4 | 1.5 | 1 ¹⁾ |
| TAJY475*050#NJ | Y | 4.7 | 50 | 2.4 | 6 | 1.2 | 1 ¹⁾ |
| TAJY685*050#NJ | Y | 6.8 | 50 | 3.4 | 6 | 0.9 | 1 ¹⁾ |

¹⁾ Dry pack option (see How to order) recommended for reduction of stress during soldering. Dry pack parts should be treated as MSL 3.

Moisture Sensitivity Level (MSL) is defined according to J-STD-020.

All technical data relates to an ambient temperature of +25°C. Capacitance and DF are measured at 120Hz, 0.5V RMS with a maximum DC bias of 2.2 volts. DCL is measured at rated voltage after 5 minutes.

For typical weight and composition see page 144.

NOTE: AVX reserves the right to supply a higher voltage rating or tighter tolerance part in the same case size, to the same reliability standards.

F92 Series



Resin-Molded Chip, Low Profile J-Lead



● Compliant to the RoHS directive (2002/95/EC).

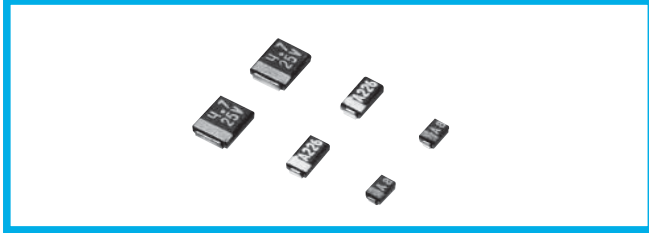

■ Marking

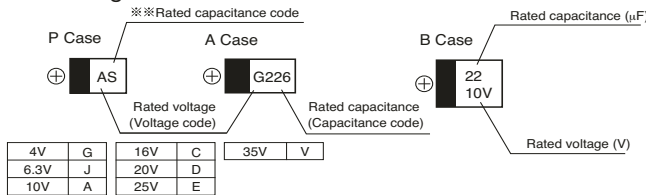

※ ※ Capacitance code of "P" case products are as shown below.

■ Specifications

| Item | Performance Characteristics | |
|-----------------------------------|---|---|
| | P Case | A · B Case |
| Category | -55 to +125°C (Rated temperature : +85°C) | |
| Temperature Range | -55 to +125°C (Rated temperature : +85°C) | |
| Capacitance Tolerance | ±20% (at 120Hz) | |
| Dissipation Factor (120Hz) | Refer to Next Page | |
| ESR (100kHz) | Refer to Next Page | |
| Leakage Current | <ul style="list-style-type: none"> After 1 minute's application of rated voltage, leakage current at 20°C is not more than 0.01CV or 0.5μA, whichever is greater. After 1 minute's application of rated voltage, leakage current at 85°C is not more than 0.1CV or 5μA, whichever is greater. After 1 minute's application of derated voltage, leakage current at 125°C is not more than 0.125CV or 6.3μA, whichever is greater. | |
| Capacitance Change by Temperature | +20% Max. (at +125°C) +15% Max. (at +85°C) -15% Max. (at -55°C) | +15% Max. (at +125°C) +10% Max. (at +85°C) -10% Max. (at -55°C) |
| Damp Heat (Steady State) | At 40°C 90 to 95% R.H. 500 hours (No voltage applied) Capacitance Change... Refer to next page (*1) Dissipation Factor...150% or less than the initial specified value Leakage Current... Initial specified value or less | Refer to next page (*1) Initial specified value or less Initial specified value or less |
| Temperature Cycles | -55°C / +125°C 30 minutes each 5 cycles Capacitance Change... Refer to next page (*1) Dissipation Factor...150% or less than the initial specified value Leakage Current... Initial specified value or less | Refer to next page (*1) Initial specified value or less Initial specified value or less |

■ Standard Ratings

| Cap. (μF) | Code | V | | 4 | | 6.3 | | 10 | | 16 | | 20 | | 25 | | 35 | | ※ ※ Capacitance code |
|-----------|------|----|----|----|----|-----|----|----|--|----|--|----|--|----|--|----|--|----------------------|
| | | OG | OJ | 1A | 1C | 1D | 1E | 1V | | | | | | | | | | |
| 0.22 | 224 | | | | | | | | | | | | | | | | | J |
| 0.33 | 334 | | | | | | | | | | | | | | | | | N |
| 0.47 | 474 | | | | | | | | | | | | | | | | | S |
| 0.68 | 684 | | | | | | | | | | | | | | | | | W |
| 1 | 105 | | | | | | | | | | | | | | | | | A |
| 1.5 | 155 | | | | | | | | | | | | | | | | | E |
| 2.2 | 225 | | | | | | | | | | | | | | | | | J |
| 3.3 | 335 | | | | | | | | | | | | | | | | | N |
| 4.7 | 475 | | | | | | | | | | | | | | | | | S |
| 6.8 | 685 | | | | | | | | | | | | | | | | | w |
| 10 | 106 | | | | | | | | | | | | | | | | | a |
| 15 | 156 | | | | | | | | | | | | | | | | | e |
| 22 | 226 | | | | | | | | | | | | | | | | | J |
| 33 | 336 | | | | | | | | | | | | | | | | | n |
| 47 | 476 | | | | | | | | | | | | | | | | | s |
| 68 | 686 | | | | | | | | | | | | | | | | | |
| 100 | 107 | | | | | | | | | | | | | | | | | |
| 150 | 157 | | | | | | | | | | | | | | | | | |
| 220 | 227 | | | | | | | | | | | | | | | | | |

■ Type numbering system (Example: 6.3V 10μF)

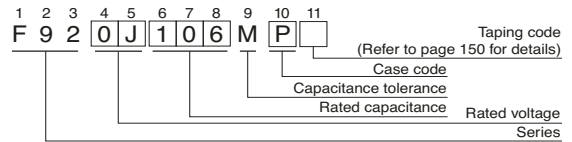

■ Drawing

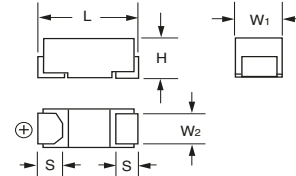

■ Dimensions

| Case code | L | W ₁ | W ₂ | H | S |
|-----------|-----------|----------------|----------------|-----------|-----------|
| P | 2.0 ± 0.2 | 1.25 ± 0.1 | 0.9 ± 0.1 | 1.1 ± 0.1 | 0.5 ± 0.2 |
| A | 3.2 ± 0.2 | 1.6 ± 0.2 | 1.2 ± 0.1 | 1.1 ± 0.1 | 0.8 ± 0.2 |
| B | 3.4 ± 0.2 | 2.8 ± 0.2 | 2.3 ± 0.1 | 1.1 ± 0.1 | 0.8 ± 0.2 |

| | | |
|------------------------------|--|--|
| Resistance to Soldering Heat | 10 seconds reflow at 260°C, 5 seconds immersion at 260°C Capacitance Change... Refer to next page (*1) Dissipation Factor...150% of less than the initial specified value Leakage Current... Initial specified value or less | Refer to next page (*1) Initial specified value or less Initial specified value or less |
| Surge | After application of surge voltage in series with a 33Ω (For "P" case : 1kΩ) resistor at the rate of 30 seconds ON, 30 seconds OFF, for 1000 successive test cycles at 85°C, capacitors shall meet the characteristic requirements table below. Capacitance Change... Refer to next page (*1) Dissipation Factor...150% or less than the initial specified value Leakage Current... Initial specified value or less | Refer to next page (*1) Initial specified value or less Initial specified value or less |
| Endurance | After 2000hours' application of rated voltage in series with a 3Ω resistor at 85°C, or derated voltage in series with a 3Ω resistor at 125°C, capacitors shall meet the characteristic requirements table below. Capacitance Change... Refer to next page (*1) Dissipation Factor...150% or less than the initial specified value Leakage Current... Initial specified value or less | After 2000hours' application of rated voltage in series with a 3Ω resistor at 85°C, or derated voltage in series with a 3Ω resistor at 125°C, capacitors shall meet the characteristic requirements table below. Capacitance Change... Refer to next page (*1) Dissipation Factor... Initial specified value or less Leakage Current... Initial specified value or less |
| Shear Test | After applying the pressure load of 5N for 10±1 seconds horizontally to the center of capacitor side body which has no electrode and has been soldered beforehand on a substrate, there shall be found neither exfoliation nor its sign at the terminal electrode. | 5N (0.51kg · f) For 10 ± 1 seconds |
| Terminal Strength | Keeping a capacitor surface-mounted on a substrate upside down and supporting the substrate at both of the opposite bottom points 45mm apart from the center of capacitor, the pressure strength is applied with a specified jig at the center of substrate so that the substrate may bend by 1mm as illustrated. Then, there shall be found no remarkable abnormality on the capacitor terminals. | R230 45 45 1mm |

() The series in parentheses are being developed. Please contact to your local AVX sales office when these series are being designed in your application.



F92 Series



Resin-Molded Chip, Low Profile J-Lead

■ Standard Ratings

| Rated Volt | Rated Capacitance (μF) | Case code | Part Number | Leakage Current (μA) | Dissipation Factor (%@120Hz) | ESR (s@100kHz) | *1 ΔC/C (%) |
|------------|------------------------|-------------|-------------|----------------------|------------------------------|----------------|-------------|
| 4V | 3.3 | P | F920G335MPA | 0.5 | 8 | 12.0 | * |
| | 4.7 | P | F920G475MPA | 0.5 | 8 | 6.0 | * |
| | 6.8 | P | F920G685MPA | 0.5 | 10 | 6.0 | * |
| | 10 | P | F920G106MPA | 0.5 | 10 | 6.0 | * |
| | 10 | A | F920G106MAA | 0.5 | 8 | 4.0 | * |
| | 15 | P | F920G156MPA | 0.6 | 10 | 5.0 | * |
| | 22 | P | F920G226MPA | 0.9 | 20 | 5.0 | * |
| | 22 | A | F920G226MAA | 0.9 | 12 | 2.8 | * |
| | 33 | P | F920G336MPA | 1.3 | 20 | 4.0 | * |
| | 33 | A | F920G336MAA | 1.3 | 12 | 2.8 | * |
| | 47 | A | F920G476MPA | 1.9 | 18 | 2.8 | * |
| | 47 | B | F920G476MBA | 1.9 | 12 | 1.7 | * |
| | 68 | A | F920G686MAA | 2.7 | 25 | 2.8 | ±15 |
| | 68 | B | F920G686MBA | 2.7 | 18 | 1.5 | * |
| | 100 | A | F920G107MAA | 4.0 | 30 | 2.8 | ±15 |
| | 100 | B | F920G107MBA | 4.0 | 18 | 1.3 | * |
| 150 | B | F920G157MBA | 6.0 | 25 | 1.3 | ±15 | |
| 6.3V | 2.2 | P | F920J225MPA | 0.5 | 8 | 12.0 | * |
| | 3.3 | P | F920J335MPA | 0.5 | 8 | 12.0 | * |
| | 4.7 | P | F920J475MPA | 0.5 | 8 | 6.0 | * |
| | 6.8 | P | F920J685MPA | 0.5 | 10 | 6.0 | * |
| | 10 | P | F920J106MPA | 0.6 | 10 | 6.0 | * |
| | 10 | A | F920J106MAA | 0.6 | 8 | 4.0 | * |
| | 15 | P | F920J156MPA | 0.9 | 10 | 6.0 | * |
| | 15 | A | F920J156MAA | 0.9 | 8 | 4.0 | * |
| | 22 | P | F920J226MPA | 1.4 | 20 | 5.0 | * |
| | 22 | A | F920J226MAA | 1.4 | 12 | 2.8 | * |
| | 33 | A | F920J336MAA | 2.1 | 12 | 2.8 | * |
| | 33 | B | F920J336MBA | 2.1 | 12 | 1.7 | * |
| | 47 | A | F920J476MAA | 3.0 | 18 | 2.8 | ±15 |
| | 47 | B | F920J476MBA | 3.0 | 12 | 1.7 | * |
| | 100 | B | F920J107MBA | 6.3 | 20 | 1.3 | ±15 |
| | 10V | 1 | P | F921A105MPA | 0.5 | 8 | 12.0 |
| 1.5 | | P | F921A155MPA | 0.5 | 8 | 12.0 | * |
| 2.2 | | P | F921A225MPA | 0.5 | 8 | 12.0 | * |
| 3.3 | | P | F921A335MPA | 0.5 | 8 | 12.0 | * |
| 3.3 | | A | F921A335MAA | 0.5 | 6 | 7.0 | * |
| 4.7 | | P | F921A475MPA | 0.5 | 8 | 6.0 | * |
| 4.7 | | A | F921A475MAA | 0.5 | 6 | 4.0 | * |
| 6.8 | | P | F921A685MPA | 0.7 | 8 | 6.0 | * |
| 6.8 | | A | F921A685MAA | 0.7 | 6 | 4.0 | * |
| 10 | | P | F921A106MPA | 1.0 | 14 | 6.0 | * |
| 10 | | A | F921A106MAA | 1.0 | 8 | 4.0 | * |
| 15 | | A | F921A156MAA | 1.5 | 8 | 4.0 | * |
| 22 | | A | F921A226MAA | 2.2 | 14 | 4.0 | ±15 |
| 22 | | B | F921A226MBA | 2.2 | 8 | 1.9 | * |
| 33 | | B | F921A336MBA | 3.3 | 12 | 1.9 | * |
| 47 | | B | F921A476MBA | 4.7 | 18 | 1.9 | ±15 |
| 16V | 0.47 | P | F921C474MPA | 0.5 | 8 | 20.0 | * |
| | 0.68 | P | F921C684MPA | 0.5 | 8 | 12.0 | * |
| | 1 | P | F921C105MPA | 0.5 | 8 | 12.0 | * |
| | 1.5 | P | F921C155MPA | 0.5 | 8 | 12.0 | * |
| | 2.2 | P | F921C225MPA | 0.5 | 8 | 12.0 | * |
| | 2.2 | A | F921C225MAA | 0.5 | 6 | 7.0 | * |
| | 3.3 | A | F921C335MAA | 0.5 | 6 | 7.0 | * |
| | 4.7 | A | F921C475MAA | 0.8 | 6 | 7.0 | * |
| | 4.7 | B | F921C475MBA | 0.8 | 6 | 3.0 | * |
| | 6.8 | B | F921C685MBA | 1.1 | 6 | 3.0 | * |
| | 10 | A | F921C106MAA | 1.6 | 8 | 7.0 | ±15 |
| | 10 | B | F921C106MBA | 1.6 | 6 | 2.0 | * |
| 22 | B | F921C226MBA | 3.5 | 12 | 2.0 | ±15 | |

| Rated Volt | Rated Capacitance (μF) | Case code | Part Number | Leakage Current (μA) | Dissipation Factor (%@120Hz) | ESR (s@100kHz) | *1 ΔC/C (%) |
|------------|------------------------|-----------|-------------|----------------------|------------------------------|----------------|-------------|
| 20V | 0.47 | P | F921D474MPA | 0.5 | 8 | 20.0 | * |
| | 0.47 | A | F921D474MAA | 0.5 | 4 | 10.0 | * |
| | 0.68 | A | F921D684MAA | 0.5 | 4 | 10.0 | * |
| | 1 | P | F921D105MPA | 0.5 | 8 | 20.0 | * |
| | 1 | A | F921D105MAA | 0.5 | 4 | 10.0 | * |
| | 1.5 | A | F921D155MAA | 0.5 | 6 | 7.4 | * |
| | 2.2 | A | F921D225MAA | 0.5 | 6 | 7.0 | * |
| | 4.7 | A | F921D475MAA | 0.9 | 10 | 7.0 | ±10 |
| | 4.7 | B | F921D475MBA | 0.9 | 6 | 3.0 | * |
| | 10 | B | F921D106MBA | 2.0 | 8 | 3.0 | ±10 |
| 25V | 1 | P | F921E105MPA | 0.5 | 8 | 20.0 | * |
| | 1 | A | F921E105MAA | 0.5 | 6 | 10.0 | * |
| | 2.2 | A | F921E225MAA | 0.6 | 8 | 10.0 | ±15 |
| | 2.2 | B | F921E225MBA | 0.6 | 6 | 4.0 | * |
| | 4.7 | A | F921E475MAA | 1.2 | 10 | 7.0 | ±10 |
| | 4.7 | B | F921E475MBA | 1.2 | 6 | 3.0 | * |
| 35V | 0.22 | A | F921V224MAA | 0.5 | 4 | 10.0 | * |
| | 0.33 | A | F921V334MAA | 0.5 | 4 | 10.0 | * |
| | 0.47 | A | F921V474MAA | 0.5 | 4 | 10.0 | * |
| | 1 | A | F921V105MAA | 0.5 | 6 | 10.0 | * |
| | 2.2 | B | F921V225MBA | 0.8 | 6 | 4.0 | ±10 |
| | 3.3 | B | F921V335MBA | 1.2 | 10 | 4.0 | ±10 |

1 : ΔC/C Marked ""

| Item | P Case (%) | A , B Case(%) |
|---------------------------|------------|---------------|
| Damp Heat | ±20 | ±10 |
| Temperature cycles | ±10 | ± 5 |
| Resistance soldering heat | ±10 | ± 5 |
| Surge | ±10 | ± 5 |
| Endurance | ±10 | ±10 |

We can consider the type of compliance to AEC-Q200. Please contact to your local AVX sales office when these series are being designed in your application.

Low Profile

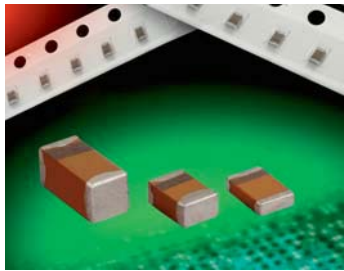

- The world's smallest surface mount tantalum capacitor
- CV range: 1.0-220µF / 2-16V
- 5 case sizes available in low profile option
- Industrial and hi-rel medical applications



CASE DIMENSIONS: millimeters (inches)

| Code | EIA Code | EIA Metric | L+0.20 (0.008) -0.00 (0.000) | W+0.15 (0.006) -0.00 (0.000) | H max | Termination Spacing(S) | Minimum Termination Length (Lt) |
|------|----------|------------|---------------------------------|--|--------------|------------------------|---------------------------------|
| H | 0805 | 2012-10 | 2.00 (0.079) | 1.35 (0.053) | 1.00 (0.039) | 0.70 (0.028) min | 0.15 (0.006) |
| J | 0603 | 1608-08 | 1.60 (0.063) | 0.85 (0.033) | 0.75 (0.030) | 0.55 (0.022) min | 0.15 (0.006) |
| T | 1210 | 3528-12 | 3.50 ± 0.20 (0.138 ± 0.008) | 2.80 ^{+0.20} _{-0.10} (0.110 ^{+0.008} _{-0.004}) | 1.20 (0.047) | 2.00 (0.079) min | 0.15 (0.006) |
| U | 0805 | 2012-06 | 2.00 (0.079) | 1.35 (0.053) | 0.60 (0.024) | 0.70 (0.028) min | 0.15 (0.006) |
| V | 1206 | 3216-08 | 3.20 ± 0.20 (0.126 ± 0.008) | 1.60 ± 0.20 (0.063 ± 0.008) | 0.75 (0.030) | 1.80 (0.071) min | 0.15 (0.006) |

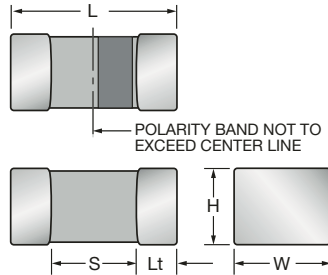

HOW TO ORDER

| | | | | | | |
|-----------------------|------------------------------|--|-------------------------------|--|---|---|
| TAC | U | 475 | M | 004 | R | TA |
| Type TACmicrochip® | Case Size See table above | Capacitance Code pF code: 1st two digits represent significant figures, 3rd digit represents multiplier (number of zeros to follow) | Tolerance K=±10% M=±20% | Rated DC Voltage 002=2Vdc 003=3Vdc 004=4Vdc 006=6.3Vdc 010=10Vdc 016=16Vdc 035=35Vdc 050=50Vdc | Packaging R = 7" Standard Tin Termination Plastic Tape X = 4 1/4" Standard Tin Termination Plastic Tape A = 7" Gold Termination Plastic Tape F = 4 1/4" Gold Termination Plastic Tape | Alternative characters may be used for special requirements |

TECHNICAL SPECIFICATIONS

| | | | | | | | | | | |
|------------------------------------|--|-----|-----|-----|-----|----|----|----|----|--|
| Technical Data: | All technical data relate to an ambient temperature of +25°C | | | | | | | | | |
| Capacitance Range: | 0.1 µF to 220 µF | | | | | | | | | |
| Capacitance Tolerance: | ±10%; ±20% | | | | | | | | | |
| Leakage Current DCL: | 0.01CV or 0.5µA whichever is the greater | | | | | | | | | |
| Rated Voltage (V _R) | ≤ +85°C: | 2 | 3 | 4 | 6.3 | 10 | 16 | 35 | 50 | |
| Category Voltage (V _C) | ≤ +125°C: | 1.3 | 2 | 2.7 | 4 | 7 | 10 | 23 | 33 | |
| Surge Voltage (V _S) | ≤ +85°C: | 2.7 | 3.9 | 5.2 | 8 | 13 | 20 | 46 | 65 | |
| Surge Voltage (V _S) | ≤ +125°C: | 1.7 | 2.6 | 3.2 | 5 | 8 | 12 | 28 | 40 | |
| Temperature Range: | -55°C to +125°C | | | | | | | | | |
| Reliability: | 1% per 1000 hours at 85°C, V _R with 0.1Ω/V series impedance, 60% confidence level | | | | | | | | | |
| Termination Finish: | Nickel and Tin Plating (standard), Nickel and Gold Plating option available upon request | | | | | | | | | |

Low Profile

LOW PROFILE & CUSTOM RANGE (LETTER DENOTES CASE SIZE)

| Capacitance | | Voltage Rating DC (V _R) at 85°C | | | | | | | |
|-------------|------|---|------------------|------------------|------------------|------------------|------------------|-----|-----|
| µF | Code | 2.0V | 3.0V | 4.0V | 6.3V | 10V | 16V | 35V | 50V |
| 0.10 | 104 | | | | | | | | H* |
| 0.15 | 154 | | | | | | | H* | |
| 0.22 | 224 | | | | | | | H* | |
| 0.33 | 334 | | | | | | | H* | |
| 0.47 | 474 | | | | | | | H* | |
| 0.68 | 684 | | | | | | | | |
| 1.0 | 105 | | | | | | U ^(M) | | |
| 1.5 | 155 | | | | | | U ^(M) | | |
| 2.2 | 225 | | | | | | U ^(M) | | |
| 3.3 | 335 | | | | U ^(M) | | | | |
| 4.7 | 475 | | | U ^(M) | U ^(M) | | | | |
| 6.8 | 685 | | | U ^(M) | U ^(M) | | | | |
| 10 | 106 | U ^(M) | | J ^(M) | | H/V | | | |
| 15 | 156 | | | | | H | | | |
| 22 | 226 | | | | | H | | | |
| 33 | 336 | | | H | | | | | |
| 47 | 476 | | H ^(M) | | | | | | |
| 68 | 686 | | | | | T | | | |
| 100 | 107 | | | | | T ^(M) | | | |
| 150 | 157 | | | | | | | | |
| 220 | 227 | | T ^(M) | | | | | | |

Not recommended for new designs, higher voltage or smaller case size substitution are offered.

Released codes ^(M tolerance only)

Engineering samples - please contact manufacturer

*Codes under development - subject to change.

Standard Height Profile: A, B, K, L, R Case

Low Profile: H, J, T, U, V Case

Note: Voltage ratings are minimum values. AVX reserves the right to supply higher ratings in the same case size, to the same reliability standards.

RATINGS & PART NUMBER REFERENCE

| AVX Part No. | EIA Code | EIA Metric | Case Size | Cap (µF) | Rated Voltage (V) | DCL (µA) Max. | DF % Max. | ESR Max. (Ω) @100kHz | MSL |
|---|----------|------------|-----------|----------|-------------------|---------------|-----------|----------------------|-----|
| 2 Volt @ 85°C (1.3 Volt @ 125°C) | | | | | | | | | |
| TACU106M002#TA | 0805 | 2012-06 | U | 10 | 2 | 0.5 | 8 | 5 | 1 |
| 3 Volt @ 40°C (2 Volt @ 125°C) | | | | | | | | | |
| TACH476M003#TA | 0805 | 2012-10 | H | 47 | 3 | 1.4 | 20 | 5 | 1 |
| TACT227M003#TA | 1210 | 3528-12 | T | 220 | 3 | 6.6 | 20 | 1 | 1 |
| 4 Volt @ 85°C (2.7 Volt @ 125°C) | | | | | | | | | |
| TACU475M004#TA | 0805 | 2012-06 | U | 4.7 | 4 | 0.5 | 8 | 5 | 1 |
| TACJ106M004#TA | 0603 | 1608-08 | J | 10 | 4 | 0.5 | 20 | 7.5 | 1 |
| TACH336*004#TA | 0805 | 2012-10 | H | 33 | 4 | 1.3 | 14 | 5 | 1 |
| 6.3 Volt @ 85°C (4 Volt @ 125°C) | | | | | | | | | |
| TACU335M006#TA | 0805 | 2012-06 | U | 3.3 | 6.3 | 0.5 | 8 | 5 | 1 |
| TACH156*006#TA | 0805 | 2012-10 | H | 15 | 6.3 | 0.9 | 8 | 5 | 1 |
| TACH226*006#TA | 0805 | 2012-10 | H | 22 | 6.3 | 1.4 | 10 | 5 | 1 |
| TACT686*006#TA | 1210 | 3528-12 | T | 68 | 6.3 | 4.3 | 15 | 1 | 1 |
| TACT107M006#TA | 1210 | 3528-12 | T | 100 | 6.3 | 6.3 | 12 | 1 | 1 |
| 10 Volt @ 85°C (7 Volt @ 125°C) | | | | | | | | | |
| TACU225M010#TA | 0805 | 2012-06 | U | 2.2 | 10 | 0.5 | 8 | 5 | 1 |
| TACH106*010#TA | 0805 | 2012-10 | H | 10 | 10 | 1.0 | 8 | 5 | 1 |
| TACV106*010#TA | 1206 | 3216-08 | V | 10 | 10 | 1.0 | 10 | 2 | 1 |
| TACV156M010#TA | 1206 | 3216-08 | V | 15 | 10 | 1.5 | 10 | 2 | 1 |
| TACT476*010#TA | 1210 | 3528-12 | T | 47 | 10 | 4.7 | 12 | 1 | 1 |
| 16 Volt @ 85°C (10 Volt @ 125°C) | | | | | | | | | |
| TACU105M016#TA | 0805 | 2012-06 | U | 1 | 16 | 0.5 | 8 | 5 | 1 |

Moisture Sensitivity Level (MSL) is defined according to J-STD-020.

All technical data relates to an ambient temperature of +25°C. Capacitance and DF are measured at 120Hz, 0.5V RMS with a maximum DC bias of 2.2 volts. DCL is measured at rated voltage after 5 minutes.

For typical weight and composition see page 144.

NOTE: AVX reserves the right to supply a higher voltage rating or tighter tolerance part in the same case size, to the same reliability standards.

TLJ Series



Tantalum Solid Electrolytic Chip Capacitors High CV Consumer Series

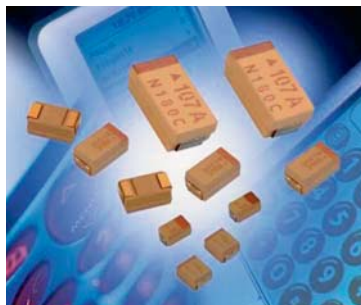

- High Volumetric Efficiency
- 3x reflow 260°C compatible
- 13 case sizes available including low profile codes
- Environmentally friendly
- Consumer applications (e.g. mobiles phones, PDA etc.)
- CV range: 10-680µF / 2.5-20V



LEAD-FREE
LEAD-FREE COMPATIBLE
COMPONENT

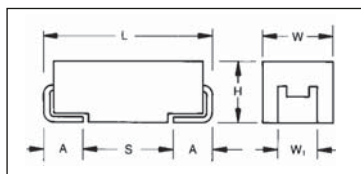

For part marking see page 151

CASE DIMENSIONS: millimeters (inches)

| Code | EIA Code | EIA Metric | L±0.20 (0.008) | W+0.20 (0.008) -0.10 (0.004) | H+0.20 (0.008) -0.10 (0.004) | W ₁ ±0.20 (0.008) | A+0.30 (0.012) -0.20 (0.008) | S Min. |
|------|----------|------------|----------------|---------------------------------|---------------------------------|------------------------------|---------------------------------|--------------|
| A | 1206 | 3216-18 | 3.20 (0.126) | 1.60 (0.063) | 1.60 (0.063) | 1.20 (0.047) | 0.80 (0.031) | 1.10 (0.043) |
| B | 1210 | 3528-21 | 3.50 (0.138) | 2.80 (0.110) | 1.90 (0.075) | 2.20 (0.087) | 0.80 (0.031) | 1.40 (0.055) |
| F | 2312 | 6032-20 | 6.00 (0.236) | 3.20 (0.126) | 2.00 (0.079) max. | 2.20 (0.087) | 1.30 (0.051) | 2.90 (0.114) |
| G | 1206 | 3216-15 | 3.20 (0.126) | 1.60 (0.063) | 1.50 (0.059) max | 1.20 (0.047) | 0.80 (0.031) | 1.10 (0.043) |
| H | 1210 | 3528-15 | 3.50 (0.138) | 2.80 (0.110) | 1.50 (0.059) max | 2.20 (0.087) | 0.80 (0.031) | 1.40 (0.055) |
| K | 1206 | 3216-10 | 3.20 (0.126) | 1.60 (0.063) | 1.00 (0.039) max | 1.20 (0.047) | 0.80 (0.031) | 1.10 (0.043) |
| N | 0805 | 2012-10 | 2.05 (0.081) | 1.30 (0.051) | 1.00 (0.039) max | 1.00 (0.039) | 0.50 (0.020) | 0.85 (0.033) |
| P | 0805 | 2012-15 | 2.05 (0.081) | 1.35 (0.053) | 1.50 (0.059) max | 1.00±0.10 (0.039±0.004) | 0.50 (0.020) | 0.85 (0.033) |
| R | 0805 | 2012-12 | 2.05 (0.081) | 1.30 (0.051) | 1.20 (0.047) max | 1.00±0.10 (0.039±0.004) | 0.50 (0.020) | 0.85 (0.033) |
| S | 1206 | 3216-12 | 3.20 (0.126) | 1.60 (0.063) | 1.20 (0.047) max | 1.20 (0.047) | 0.80 (0.031) | 1.10 (0.043) |
| T | 1210 | 3528-12 | 3.50 (0.138) | 2.80 (0.110) | 1.20 (0.047) max | 2.20 (0.087) | 0.80 (0.031) | 1.40 (0.033) |
| W | 2312 | 6032-15 | 6.00 (0.236) | 3.20 (0.126) | 1.50 (0.059) max | 2.20 (0.087) | 1.30 (0.051) | 2.90 (0.114) |
| Y | 2917 | 7343-20 | 7.30 (0.287) | 4.30 (0.169) | 2.00 (0.079) max | 2.40 (0.094) | 1.30 (0.051) | 4.40 (0.173) |

W1 dimension applies to the termination width for A dimensional area only.

HOW TO ORDER

TLJ

Type

W

Case Size
See table above

157

Capacitance Code
pF code: 1st two digits represent significant figures, 3rd digit represents multiplier (number of zeros to follow)

M

Tolerance
M = ±20%

010

Rated DC Voltage
002 = 2.5Vdc
004 = 4Vdc
006 = 6.3Vdc
010 = 10Vdc
016 = 16Vdc
020 = 20Vdc

R

Packaging
R = Pure Tin 7" Reel
S = Pure Tin 13" Reel

0200

ESR in mΩ

TECHNICAL SPECIFICATIONS

Technical Data:

All technical data relate to an ambient temperature of +25°C

Capacitance Range:

10 µF to 680 µF

Capacitance Tolerance:

±20%

Rated Voltage (V_R)

-55°C ≤ +40°C:

2.5 4 6.3 10 16 20

Category Voltage (V_C)

at 85°C:

1.25 2 3.15 5 8 10

Category Voltage (V_C)

at 125°C:

0.5 0.8 1.26 2 3.2 4

Temperature Range:

-55°C to +125°C with category voltage

Reliability:

0.2% per 1000 hours at 85°C, 0.5xV_R with 0.1Ω/V series impedance with 60% confidence level



TLJ Series



Tantalum Solid Electrolytic Chip Capacitors High CV Consumer Series

CAPACITANCE AND RATED VOLTAGE, VR (VOLTAGE CODE) RANGE (LETTER DENOTES CASE SIZE)

| Capacitance | | Rated Voltage DC to 40°C / 0.5DC to 85°C / 0.2DC to 125°C | | | | | | |
|-------------|------|---|---|--|---|---------|---------|---------|
| µF | Code | 2.5V (e) | 4V (G) | 6.3V (J) | 10V (A) | 16V (C) | 20V (D) | 35V (V) |
| 6.8 | 685 | | | | | | | |
| 10 | 106 | | | | N(2500) R(2000,3000) | S(2200) | T(1000) | |
| 15 | 156 | | | | R(2000) | | | |
| 22 | 226 | | | N(5400)/R(3500) | K(1800)/N(3800) R(3800) | T(1000) | | |
| 33 | 336 | | N(8000)/R(3000) | K(1700)/N(8000) P(3000)/R(3000) | K(1500)/N(9600) P(3500) R(3500)/S(1500) | T(1000) | | |
| 47 | 476 | | K(1500)/N(4000) P(3000)/R(3000) | K(1500)/N(8300) P(700,900,1800,2500) R(3200)/S(1500) | A(600)/G(1500) P(3200)/R(3200) S(1500)/T(600) | | | |
| 68 | 686 | | K(1200)/N(8000) P(3000) R(2900)/S(1500) | A(500)/G(800) S(1500)/T(600) | A(1500) | | | |
| 100 | 107 | | A(500)/G(800) N(5200)/P(2700) S(1400) | A(500,800)/G(800) P(5400)/T(800) | A(1400) H(900)/T(900) | | | |
| 150 | 157 | | A(800)/T(800) | A(900)/G(2500) H(900)/T(1200) | B(500) W(150,200) | | | |
| 220 | 227 | T(1100) | A(1100)/G(3000) H(900)/T(1100) | B(500)/T(2000) W(200) | F(300) | | | |
| 330 | 337 | | T(2700)/W(200) | F(300) | | | | |
| 470 | 477 | | | | | | | |
| 680 | 687 | | | Y(100,150) | | | | |
| 1000 | 108 | | | | | | | |
| 1500 | 158 | | | | | | | |

Available Ratings, (ESR ratings in mOhms in brackets)

Engineering samples - please contact manufacturer

*Codes under development - subject to change

Note: Voltage ratings are minimum values. AVX reserves the right to supply higher ratings in the same case size, to the same reliability standards.

TLJ Series



Tantalum Solid Electrolytic Chip Capacitors High CV Consumer Series

RATINGS & PART NUMBER REFERENCE

| AVX Part No. | Case Size | Capacitance (µF) | Rated Voltage (V) | Maximum Surge Current (A)* | DCL (µA) Max. | ESR Max. (mΩ) @100kHz | MSL | 100kHz Ripple Current (mA) | | | 100kHz Ripple Voltage (mV) | | |
|--|-----------|------------------|-------------------|----------------------------|---------------|-----------------------|-----|----------------------------|------|-------|----------------------------|------|-------|
| | | | | | | | | 25°C | 85°C | 125°C | 25°C | 85°C | 125°C |
| 2.5 Volt @ 40°C (1.25 Volt @ 85°C, 0.5 Volt @ 125°C) | | | | | | | | | | | | | |
| TLJT227M002#1200 | T | 220 | 2.5 | 0.8 | 5.5 | 1100 | 3 | 365 | 329 | 146 | 219 | 197 | 88 |
| 4 Volt @ 40°C (2 Volt @ 85°C, 0.8 Volt @ 125°C) | | | | | | | | | | | | | |
| TLJN336M004#8000 | N | 33 | 4 | 0.2 | 1.3 | 8000 | 3 | 79 | 71 | 32 | 632 | 569 | 253 |
| TLJR336M004#3000 | R | 33 | 4 | 0.6 | 1.3 | 3000 | 3 | 135 | 122 | 54 | 406 | 366 | 162 |
| TLJK476M004#1500 | K | 47 | 4 | 1.0 | 1.9 | 1500 | 3 | 208 | 187 | 83 | 312 | 281 | 125 |
| TLJN476M004#4000 | N | 47 | 4 | 0.6 | 1.9 | 4000 | 3 | 112 | 101 | 45 | 447 | 402 | 179 |
| TLJP476M004#3000 | P | 47 | 4 | 0.6 | 1.9 | 3000 | 3 | 141 | 127 | 57 | 424 | 382 | 170 |
| TLJR476M004#3000 | R | 47 | 4 | 0.6 | 1.9 | 3000 | 3 | 135 | 122 | 54 | 406 | 366 | 162 |
| TLJK686M004#1200 | K | 68 | 4 | 1.2 | 2.7 | 1200 | 3 | 233 | 209 | 93 | 279 | 251 | 112 |
| TLJN686M004#8000 | N | 68 | 4 | 0.2 | 5.4 | 8000 | 3 | 79 | 71 | 32 | 632 | 569 | 253 |
| TLJP686M004#3000 | P | 68 | 4 | 1.2 | 2.7 | 3000 | 3 | 141 | 127 | 57 | 424 | 382 | 170 |
| TLJR686M004#2900 | R | 68 | 4 | 0.6 | 2.7 | 2900 | 3 | 138 | 124 | 55 | 399 | 359 | 160 |
| TLJS686M004#1500 | S | 68 | 4 | 1.0 | 2.7 | 1500 | 3 | 208 | 187 | 83 | 312 | 281 | 125 |
| TLJA107M004#0500 | A | 100 | 4 | 2.1 | 4.0 | 500 | 3 | 387 | 349 | 155 | 194 | 174 | 77 |
| TLJG107M004#0800 | G | 100 | 4 | 1.6 | 4.0 | 800 | 3 | 296 | 266 | 118 | 237 | 213 | 95 |
| TLJN107M004#5200 | N | 100 | 4 | 0.4 | 8.0 | 5200 | 3 | 98 | 88 | 39 | 510 | 459 | 204 |
| TLJP107M004#2700 | P | 100 | 4 | 0.6 | 8.0 | 2700 | 3 | 149 | 134 | 60 | 402 | 362 | 161 |
| TLJS107M004#1400 | S | 100 | 4 | 1.1 | 4.0 | 1400 | 3 | 208 | 187 | 83 | 312 | 281 | 125 |
| TLJA157M004#0800 | A | 150 | 4 | 1.6 | 6.0 | 800 | 3 | 306 | 276 | 122 | 245 | 220 | 98 |
| TLJT157M004#0800 | T | 150 | 4 | 1.6 | 6.0 | 800 | 3 | 316 | 285 | 126 | 253 | 228 | 101 |
| TLJA227M004#1100 | A | 220 | 4 | 1.3 | 17.6 | 1100 | 3 | 261 | 235 | 104 | 287 | 259 | 115 |
| TLJG227M004#3000 | G | 220 | 4 | 0.6 | 17.6 | 3000 | 3 | 153 | 137 | 61 | 458 | 412 | 183 |
| TLJH227M004#0900 | H | 220 | 4 | 1.5 | 8.8 | 900 | 3 | 298 | 268 | 119 | 268 | 241 | 107 |
| TLJT227M004#1100 | T | 220 | 4 | 1.3 | 17.6 | 1100 | 3 | 316 | 285 | 126 | 253 | 228 | 101 |
| TLJT337M004#2700 | T | 330 | 4 | 0.6 | 26.4 | 2700 | 3 | 172 | 155 | 69 | 465 | 418 | 186 |
| TLJW337M004#0200 | W | 330 | 4 | 3.1 | 13.2 | 200 | 3 | 671 | 604 | 268 | 134 | 121 | 54 |
| 6.3 Volt @ 40°C (3.15 Volt @ 85°C, 1.26 Volt @ 125°C) | | | | | | | | | | | | | |
| TLJN226M006#5400 | N | 22 | 6.3 | 0.5 | 1.3 | 5400 | 3 | 96 | 87 | 38 | 520 | 468 | 208 |
| TLJR226M006#3500 | R | 22 | 6.3 | 0.8 | 1.3 | 3500 | 3 | 125 | 113 | 50 | 439 | 395 | 175 |
| TLJK336M006#1700 | K | 33 | 6.3 | 1.5 | 2.0 | 1700 | 3 | 196 | 176 | 78 | 332 | 299 | 133 |
| TLJN336M006#8000 | N | 33 | 6.3 | 0.4 | 2.0 | 8000 | 3 | 79 | 71 | 32 | 632 | 569 | 253 |
| TLJP336M006#3000 | P | 33 | 6.3 | 0.9 | 2.0 | 3000 | 3 | 141 | 127 | 57 | 424 | 382 | 170 |
| TLJR336M006#3000 | R | 33 | 6.3 | 0.9 | 2.0 | 3000 | 3 | 135 | 122 | 54 | 406 | 366 | 162 |
| TLJK476M006#1500 | K | 47 | 6.3 | 1.6 | 2.8 | 1500 | 3 | 208 | 187 | 83 | 312 | 281 | 125 |
| TLJN476M006#8300 | N | 47 | 6.3 | 0.4 | 5.6 | 8300 | 3 | 78 | 70 | 31 | 644 | 580 | 258 |
| TLJP476M006#0700 | P | 47 | 6.3 | 2.7 | 2.8 | 700 | 3 | 293 | 263 | 117 | 205 | 184 | 82 |
| TLJP476M006#0900 | P | 47 | 6.3 | 2.3 | 2.8 | 900 | 3 | 258 | 232 | 103 | 232 | 209 | 93 |
| TLJP476M006#1800 | P | 47 | 6.3 | 1.4 | 2.8 | 1800 | 3 | 183 | 164 | 73 | 329 | 296 | 131 |
| TLJP476M006#2500 | P | 47 | 6.3 | 1.1 | 2.8 | 2500 | 3 | 155 | 139 | 62 | 387 | 349 | 155 |
| TLJR476M006#3200 | R | 47 | 6.3 | 0.9 | 2.8 | 3200 | 3 | 131 | 118 | 52 | 420 | 378 | 168 |
| TLJS476M006#1500 | S | 47 | 6.3 | 1.6 | 2.8 | 1500 | 3 | 208 | 187 | 83 | 312 | 281 | 125 |
| TLJA686M006#0500 | A | 68 | 6.3 | 3.3 | 4.1 | 500 | 3 | 387 | 349 | 155 | 194 | 174 | 77 |
| TLJG686M006#0800 | G | 68 | 6.3 | 1.9 | 4.1 | 800 | 3 | 242 | 217 | 97 | 290 | 261 | 116 |
| TLJS686M006#1500 | S | 68 | 6.3 | 1.6 | 4.1 | 1500 | 3 | 208 | 187 | 83 | 312 | 281 | 125 |
| TLJT686M006#0600 | T | 68 | 6.3 | 3.0 | 4.1 | 600 | 3 | 365 | 329 | 146 | 219 | 197 | 88 |
| TLJA107M006#0500 | A | 100 | 6.3 | 3.3 | 6.0 | 500 | 3 | 387 | 349 | 155 | 194 | 174 | 77 |
| TLJA107M006#0800 | A | 100 | 6.3 | 2.5 | 6.0 | 800 | 3 | 306 | 276 | 122 | 245 | 220 | 98 |
| TLJG107M006#0800 | G | 100 | 6.3 | 2.5 | 6.0 | 800 | 3 | 296 | 266 | 118 | 237 | 213 | 95 |
| TLJP107M006#5400 | P | 100 | 6.3 | 0.5 | 12.0 | 5400 | 3 | 105 | 95 | 42 | 596 | 512 | 228 |
| TLJT107M006#0800 | T | 100 | 6.3 | 2.5 | 6.0 | 800 | 3 | 316 | 285 | 126 | 253 | 228 | 101 |
| TLJA157M006#0900 | A | 150 | 6.3 | 2.3 | 9.0 | 900 | 3 | 289 | 260 | 115 | 260 | 234 | 104 |
| TLJG157M006#2500 | G | 150 | 6.3 | 1.1 | 18.0 | 2500 | 3 | 167 | 151 | 67 | 418 | 376 | 167 |
| TLJH157M006#0900 | H | 150 | 6.3 | 2.3 | 9.0 | 900 | 3 | 298 | 268 | 119 | 268 | 241 | 107 |
| TLJT157M006#1200 | T | 150 | 6.3 | 1.9 | 9.0 | 1200 | 3 | 316 | 285 | 126 | 253 | 228 | 101 |
| TLJB227M006#0500 | B | 220 | 6.3 | 3.3 | 13.2 | 500 | 3 | 412 | 371 | 165 | 206 | 186 | 82 |
| TLJT227M006#2000 | T | 220 | 6.3 | 1.3 | 26.4 | 2000 | 3 | 200 | 180 | 80 | 400 | 360 | 160 |
| TLJW227M006#0200 | W | 220 | 6.3 | 4.8 | 13.2 | 200 | 3 | 671 | 604 | 268 | 134 | 121 | 54 |
| TLJF337M006#0300 | F | 330 | 6.3 | 4.2 | 19.8 | 300 | 3 | 577 | 520 | 231 | 173 | 156 | 69 |
| TLJY687M006#0100 | Y | 680 | 6.3 | 5.7 | 40.8 | 100 | 3 | 1118 | 1006 | 447 | 112 | 101 | 45 |
| TLJY687M006#0150 | Y | 680 | 6.3 | 5.7 | 40.8 | 150 | 3 | 913 | 822 | 365 | 137 | 123 | 55 |

Moisture Sensitivity Level (MSL) is defined according to J-STD-020.

All technical data relates to an ambient temperature of +25°C. Capacitance and DF are measured at 120Hz, 0.5V RMS with a maximum DC bias of 2.2 volts. DCL is measured at rated voltage after 5 minutes.

ESR allowed to move up to 1.25 times catalogue limit post mounting
DCL allowed to move up to 2.00 times catalogue limit post mounting

For typical weight and composition see page 144.

NOTE: AVX reserves the right to supply a higher voltage rating or tighter tolerance part in the same case size, to the same reliability standards.



TLJ Series



Tantalum Solid Electrolytic Chip Capacitors High CV Consumer Series

RATINGS & PART NUMBER REFERENCE

| AVX Part No. | Case Size | Capacitance (µF) | Rated Voltage (V) | Maximum Surge Current (A)* | DCL (µA) Max. | ESR Max. (mΩ) @100kHz | MSL | 100kHz Ripple Current (mA) | | | 100kHz Ripple Voltage (mV) | | |
|---|-----------|------------------|-------------------|----------------------------|---------------|-----------------------|-----|----------------------------|------|-------|----------------------------|------|-------|
| | | | | | | | | 25°C | 85°C | 125°C | 25°C | 85°C | 125°C |
| 10 Volt @ 40°C (5 Volt @ 85°C, 2 Volt @ 125°C) | | | | | | | | | | | | | |
| TLJN106M010#2500 | N | 10 | 10 | 1.7 | 1.0 | 2500 | 3 | 141 | 127 | 57 | 354 | 318 | 141 |
| TLJR106M010#2000 | R | 10 | 10 | 2.0 | 1.0 | 2000 | 3 | 166 | 149 | 66 | 332 | 298 | 133 |
| TLJR106M010#3000 | R | 10 | 10 | 1.4 | 1.0 | 3000 | 3 | 135 | 122 | 54 | 406 | 366 | 162 |
| TLJR156M010#2000 | R | 15 | 10 | 2.0 | 1.5 | 2000 | 3 | 166 | 149 | 66 | 332 | 298 | 133 |
| TLJK226M010#1800 | K | 22 | 10 | 2.2 | 2.2 | 1800 | 3 | 190 | 171 | 76 | 342 | 308 | 137 |
| TLJN226M010#3800 | N | 22 | 10 | 1.2 | 2.2 | 3800 | 3 | 115 | 103 | 46 | 436 | 392 | 174 |
| TLJR226M010#3800 | R | 22 | 10 | 1.2 | 2.2 | 3800 | 3 | 120 | 108 | 48 | 457 | 411 | 183 |
| TLJK336M010#1500 | K | 33 | 10 | 2.6 | 3.3 | 1500 | 3 | 208 | 187 | 83 | 312 | 281 | 125 |
| TLJN336M010#9600 | N | 33 | 10 | 0.5 | 6.6 | 9600 | 3 | 72 | 65 | 29 | 693 | 624 | 277 |
| TLJP336M010#3500 | P | 33 | 10 | 1.3 | 3.3 | 3500 | 3 | 141 | 127 | 57 | 424 | 382 | 170 |
| TLJR336M010#3500 | R | 33 | 10 | 1.3 | 3.3 | 3500 | 3 | 125 | 113 | 50 | 439 | 395 | 175 |
| TLJS336M010#1500 | S | 33 | 10 | 2.6 | 3.3 | 1500 | 3 | 208 | 187 | 83 | 312 | 281 | 125 |
| TLJA476M010#0600 | A | 47 | 10 | 4.8 | 4.7 | 600 | 3 | 354 | 318 | 141 | 212 | 191 | 85 |
| TLJG476M010#1500 | G | 47 | 10 | 2.6 | 4.7 | 1500 | 3 | 216 | 194 | 86 | 324 | 292 | 130 |
| TLJP476M010#3200 | P | 47 | 10 | 1.4 | 4.7 | 3200 | 3 | 137 | 123 | 55 | 438 | 394 | 175 |
| TLJR476M010#3200 | R | 47 | 10 | 1.4 | 9.4 | 3200 | 3 | 131 | 118 | 52 | 420 | 378 | 168 |
| TLJS476M010#1500 | S | 47 | 10 | 2.6 | 4.7 | 1500 | 3 | 208 | 187 | 83 | 312 | 281 | 125 |
| TLJT476M010#0600 | T | 47 | 10 | 4.8 | 4.7 | 600 | 3 | 365 | 329 | 146 | 219 | 197 | 88 |
| TLJA686M010#1500 | A | 68 | 10 | 2.6 | 6.8 | 1500 | 3 | 224 | 201 | 89 | 335 | 302 | 134 |
| TLJA107M010#1400 | A | 100 | 10 | 2.7 | 10.0 | 1400 | 3 | 231 | 208 | 93 | 324 | 292 | 130 |
| TLJH107M010#0900 | H | 100 | 10 | 3.7 | 10.0 | 900 | 3 | 298 | 268 | 119 | 268 | 241 | 107 |
| TLJT107M010#0900 | T | 100 | 10 | 3.7 | 10.0 | 900 | 3 | 298 | 268 | 119 | 268 | 241 | 107 |
| TLJB157M010#0500 | B | 150 | 10 | 5.3 | 15.0 | 500 | 3 | 412 | 371 | 165 | 206 | 186 | 82 |
| TLJW157M010#0150 | W | 150 | 10 | 8.3 | 15.0 | 150 | 3 | 775 | 697 | 310 | 116 | 105 | 46 |
| TLJW157M010#0200 | W | 150 | 10 | 7.7 | 15.0 | 200 | 3 | 671 | 604 | 268 | 134 | 121 | 54 |
| TLJF227M010#0300 | F | 220 | 10 | 6.7 | 22.0 | 300 | 3 | 577 | 520 | 231 | 173 | 156 | 69 |
| 16 Volt @ 40°C (8 Volt @ 85°C, 3.2 Volt @ 125°C) | | | | | | | | | | | | | |
| TLJS106M016#2200 | S | 10 | 16 | 3.0 | 1.6 | 2200 | 3 | 172 | 155 | 69 | 378 | 340 | 151 |
| TLJT226M016#1000 | T | 22 | 16 | 5.5 | 3.5 | 1000 | 3 | 283 | 255 | 113 | 283 | 255 | 113 |
| TLJT336M016#1000 | T | 33 | 16 | 5.5 | 5.3 | 1000 | 3 | 283 | 255 | 113 | 283 | 255 | 113 |
| 20 Volt @ 40°C (10 Volt @ 85°C, 4 Volt @ 125°C) | | | | | | | | | | | | | |
| TLJT106M020#1000 | T | 10 | 20 | 6.9 | 2.0 | 1000 | 3 | 283 | 255 | 113 | 283 | 255 | 113 |

Moisture Sensitivity Level (MSL) is defined according to J-STD-020.

All technical data relates to an ambient temperature of +25°C. Capacitance and DF are measured at 120Hz, 0.5V RMS with a maximum DC bias of 2.2 volts. DCL is measured at rated voltage after 5 minutes.

ESR allowed to move up to 1.25 times catalogue limit post mounting
DCL allowed to move up to 2.00 times catalogue limit post mounting

For typical weight and composition see page 144.

NOTE: AVX reserves the right to supply a higher voltage rating or tighter tolerance part in the same case size, to the same reliability standards.

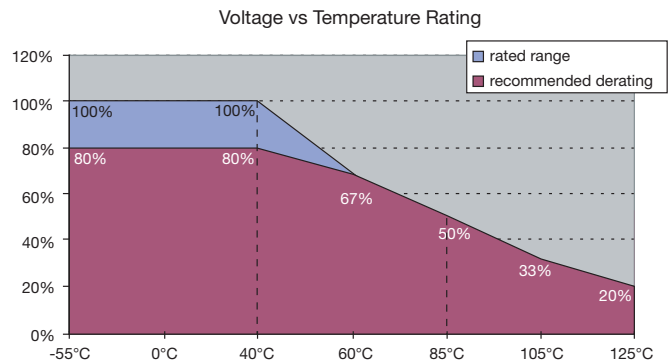

TLC Series



Tantalum Solid Electrolytic Chip Capacitors Consumer Series



- High capacitance vs. voltage ratio
- Super high volumetric efficiency
- CV range: 0.47-220 μ F / 2-35V
- 10 case sizes available
- Consumer applications (portable hand-held electronics, cellular phones, digital equipments etc.)



SnPb termination option is not RoHS compliant.

CASE DIMENSIONS: millimeters (inches)

| Code | EIA Code | EIA Metric | L+0.20 (0.008) -0.00 (0.000) | W+0.15 (0.006) -0.00 (0.000) | H+0.15 (0.006) -0.00 (0.000) | Termination Spacing(S) | Minimum Termination Length (Lt) |
|------|----------|------------|--|--|--|------------------------|---------------------------------|
| A | 1206 | 3216-18 | 3.20 \pm 0.20 (0.126 \pm 0.008) | 1.60 \pm 0.20 (0.063 \pm 0.008) | 1.60 \pm 0.20 (0.063 \pm 0.008) | 1.80 (0.071) min | 0.15 (0.006) |
| C | 1206 | 3216-10 | 3.20 \pm 0.20 (0.126 \pm 0.008) | 1.60 \pm 0.20 (0.063 \pm 0.008) | 1.00 (0.039) max | 1.80 (0.071) min | 0.15 (0.006) |
| H | 0805 | 2012-10 | 2.00 (0.079) | 1.35 (0.053) | 1.00 (0.039) max | 0.70 (0.028) min | 0.15 (0.006) |
| J | 0603 | 1608-08 | 1.60 (0.063) | 0.85 (0.033) | 0.75 (0.030) max | 0.55 (0.022) min | 0.15 (0.006) |
| K | 0402 | 1005-07 | 1.00 (0.039) | 0.50 $^{+0.20}_{-0.00}$ (0.020 $^{+0.008}_{-0.000}$) | 0.50 $^{+0.20}_{-0.00}$ (0.020 $^{+0.008}_{-0.000}$) | 0.40 (0.016) min | 0.10 (0.004) |
| L | 0603 | 1608-10 | 1.60 (0.063) | 0.85 (0.033) | 0.85 (0.033) | 0.55 (0.022) min | 0.15 (0.006) |
| M | 0803 | 2008-10 | 2.00 (0.079) | 0.85 (0.033) | 0.85 (0.033) | 0.70 (0.028) min | 0.15 (0.006) |
| N | 0402 | 1005-05 | 1.00 \pm 0.05 (0.039 \pm 0.002) | 0.50 $^{+0.00}_{-0.10}$ (0.020 $^{+0.000}_{-0.004}$) | 0.50 $^{+0.00}_{-0.10}$ (0.020 $^{+0.000}_{-0.004}$) | 0.40 (0.016) min | 0.10 (0.004) |
| Q | 0805 | 2012-12 | 2.00 (0.079) | 1.35 (0.053) | 1.20 (0.047) max | 0.70 (0.028) min | 0.15 (0.006) |
| R | 0805 | 2012-15 | 2.00 (0.079) | 1.35 (0.053) | 1.35 (0.053) | 0.70 (0.028) min | 0.15 (0.006) |
| S | 1206 | 3216-12 | 3.20 \pm 0.20 (0.126 \pm 0.008) | 1.60 \pm 0.20 (0.063 \pm 0.008) | 1.20 (0.047) max | 1.80 (0.071) min | 0.15 (0.006) |
| T | 1210 | 3528-12 | 3.50 \pm 0.20 (0.138 \pm 0.008) | 2.80 $^{+0.20}_{-0.10}$ (0.110 $^{+0.008}_{-0.004}$) | 1.20 (0.047) max | 2.00 (0.079) min | 0.15 (0.006) |
| U | 0805 | 2012-06 | 2.00 (0.079) | 1.35 (0.053) | 0.60 (0.024) max | 0.70 (0.028) min | 0.15 (0.006) |
| V | 1206 | 3216-08 | 3.20 \pm 0.20 (0.126 \pm 0.008) | 1.60 \pm 0.20 (0.063 \pm 0.008) | 0.75 (0.030) max | 1.80 (0.071) min | 0.15 (0.006) |
| Z | 0602 | 1605-07 | 1.60 (0.063) | 0.50 $^{+0.20}_{-0.00}$ (0.020 $^{+0.008}_{-0.000}$) | 0.50 $^{+0.20}_{-0.00}$ (0.020 $^{+0.008}_{-0.000}$) | 0.55 (0.022) min | 0.15 (0.006) |

Under development

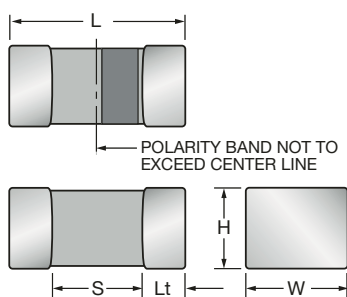

TLC Series



Tantalum Solid Electrolytic Chip Capacitors Consumer Series

HOW TO ORDER

| | | | | | | |
|-------------|-------------------------------------|---|----------------------------|---|--|--|
| TLC | L | 226 | M | 006 | R | TA |
| Type | Case Size See table above | Capacitance Code pF code: 1st two digits represent significant figures, 3rd digit represents multiplier (number of zeros to follow) | Tolerance M=±20% | Rated DC Voltage 002=2Vdc 003=3Vdc 004=4Vdc 006=6.3Vdc 008=8Vdc 010=10Vdc 016=16Vdc 020=20Vdc 025=25Vdc 035=35Vdc 050=50Vdc | Packaging R, P = 7" Standard Tin Termination Plastic Tape X, Q = 4 1/4" Standard Tin Termination Plastic Tape A = 7" Gold Termination Plastic Tape F = 4 1/4" Gold Termination Plastic Tape | Standard Suffix OR 4000 ESR in mΩ |

TECHNICAL SPECIFICATIONS

| | | | | | | | | | | | | |
|------------------------------------|--|-----|-----|-----|-----|-----|----|-----|----|------|------|----|
| Technical Data: | All technical data relate to an ambient temperature of +25°C | | | | | | | | | | | |
| Capacitance Range: | 0.33 μF to 470 μF | | | | | | | | | | | |
| Capacitance Tolerance: | ±20% | | | | | | | | | | | |
| Rated Voltage (V _R) | -55°C ≤ +40°C: | 2 | 3 | 4 | 6.3 | 8 | 10 | 16 | 20 | 25 | 35 | 50 |
| Category Voltage (V _C) | at 85°C: | 1 | 1.5 | 2 | 3.2 | 4 | 5 | 8 | 10 | 12.5 | 17.5 | 25 |
| Category Voltage (V _C) | at 125°C: | 0.4 | 0.6 | 0.8 | 1.3 | 1.6 | 2 | 3.2 | 4 | 5 | 7 | 10 |
| Temperature Range: | -55°C to +125°C with category voltage | | | | | | | | | | | |
| Reliability: | 0.2% per 1000 hours at 85°C, 0.5xV _R with 0.1Ω/V series impedance with 60% confidence level | | | | | | | | | | | |

CAPACITANCE AND RATED VOLTAGE, VR (VOLTAGE CODE) RANGE (LETTER DENOTES CASE SIZE)

| Capacitance | | Voltage Rating DC (V _R) to 40°C | | | | | | | | | | |
|-------------|------|---|------|------------|-----------------|----|------------------|------|------|-----|------|-----|
| μF | Code | 2.0V | 3.0V | 4.0V | 6.3V | 8V | 10V | 16V | 20V | 25V | 35V | 50V |
| 0.33 | 334 | | | | | | N* | J* | | L* | | |
| 0.47 | 474 | | | | | | | K | | | | |
| 0.68 | 684 | | | | | | | | | | | |
| 1.0 | 105 | | | | | | | J*/K | J* | L | L*/R | R* |
| 1.5 | 155 | | | | | | | | | | | |
| 2.2 | 225 | | | | | | J*/K | J* | H/L* | H/R | | |
| 3.3 | 335 | | | | | | | L | | | | |
| 4.7 | 475 | | | K/N* | K/U | | J/K* | | | | R* | |
| 6.8 | 685 | | K | K | | | U | | | | | |
| 10 | 106 | | K | J/K/Z | J/K/Z | | J*/K*/U/Z* | V | R | | A* | |
| 15 | 156 | K | K* | K/Z* | | | H/L | | | | | |
| 22 | 226 | J | J | J*/U | L/U | | L/M | | | T* | | |
| 33 | 336 | | | L/U | H/L/L(4000)/U/V | L | H/M* | | | | | |
| 47 | 476 | L | L | H/L | H/L*/V | | C*/H*/L*/Q*/R/V* | | | | | |
| 68 | 686 | | | R | R | | A*/R* | | | | | |
| 100 | 107 | | H* | C*/H*/Q*/R | H*/R/V* | | R*/T | | | | | |
| 150 | 157 | | | R* | R* | | A* | | | | | |
| 220 | 227 | R* | S* | A*/R*/T | A* | | T* | | | | | |
| 330 | 337 | | | A* | T* | | | | | | | |
| 470 | 477 | A* | | A*/T* | | | | | | | | |
| 680 | 687 | | | | | | | | | | | |

Released Codes

Engineering samples - please contact manufacturer

*Codes under development - subject to change.

Note: Voltage ratings are minimum values. AVX reserves the right to supply higher ratings in the same case size, to the same reliability standards.



TLC Series



Tantalum Solid Electrolytic Chip Capacitors Consumer Series

RATINGS & PART NUMBER REFERENCE

| AVX Part No. | EIA Code | EIA Metric | Case Size | Cap (µF) | Rated Voltage (V) | DCL (µA) Max. | ESR Max. (Ω) @100kHz | MSL |
|--|----------|------------|-----------|----------|-------------------|---------------|----------------------|-----|
| 2 Volt @ 40°C (1 Volt @ 85°C, 0.4 Volt @ 125°C) | | | | | | | | |
| TLC156M002#TA | 0402 | 1005-07 | K | 15 | 2 | 0.5 | 15 | 3 |
| TLCJ226M002#TA | 0603 | 1608-08 | J | 22 | 2 | 0.5 | 7.5 | 3 |
| TLCJ476M002#TA | 0603 | 1608-10 | L | 47 | 2 | 0.9 | 7.5 | 3 |
| TLCR227M002#TA | 0805 | 2012-15 | R | 220 | 2 | 4.4 | 5 | 3 |
| TLCA477M002#TA | 1206 | 3216-18 | A | 470 | 2 | 9.4 | 1 | 3 |
| 3 Volt @ 40°C (1.5 Volt @ 85°C, 0.6 Volt @ 125°C) | | | | | | | | |
| TLC685M003#TA | 0402 | 1005-07 | K | 6.8 | 3 | 0.5 | 15 | 3 |
| TLC106M003#TA | 0402 | 1005-07 | K | 10 | 3 | 0.5 | 15 | 3 |
| TLC156M003#TA | 0402 | 1005-07 | K | 15 | 3 | 0.5 | 15 | 3 |
| TLCJ226M003#TA | 0603 | 1608-08 | J | 22 | 3 | 0.7 | 7.5 | 3 |
| TLCJ476M003#TA | 0603 | 1608-10 | L | 47 | 3 | 1.4 | 7.5 | 3 |
| TLCH107M003#TA | 0805 | 2012-10 | H | 100 | 3 | 3.0 | 5 | 3 |
| TLC527M003#TA | 1206 | 3216-12 | S | 220 | 3 | 6.6 | 2 | 3 |
| 4 Volt @ 40°C (2 Volt @ 85°C, 0.8 Volt @ 125°C) | | | | | | | | |
| TLC475M004#TA | 0402 | 1005-07 | K | 4.7 | 4 | 0.5 | 15 | 3 |
| TLCN475M004#TA | 0402 | 1005-05 | N | 4.7 | 4 | 0.5 | 20 | 3 |
| TLC685M004#TA | 0402 | 1005-07 | K | 6.8 | 4 | 0.5 | 15 | 3 |
| TLCJ106M004#TA | 0603 | 1608-08 | J | 10 | 4 | 0.5 | 7.5 | 3 |
| TLCJ106M004#TA | 0402 | 1005-07 | K | 10 | 4 | 0.5 | 15 | 3 |
| TLCZ106M004#TA | 0602 | 1605-07 | Z | 10 | 4 | 0.5 | 15 | 3 |
| TLC156M004#TA | 0402 | 1005-07 | K | 15 | 4 | 3.0 | 15 | 3 |
| TLCJ226M004#TA | 0603 | 1608-08 | J | 22 | 4 | 0.9 | 7.5 | 3 |
| TLCU226M004#TA | 0805 | 2012-06 | U | 22 | 4 | 0.9 | 12 | 3 |
| TLC1336M004#TA | 0603 | 1608-10 | L | 33 | 4 | 1.3 | 7.5 | 3 |
| TLCU336M004#TA | 0805 | 2012-06 | U | 33 | 4 | 2.6 | 9 | 3 |
| TLC476M004#TA | 0805 | 2012-10 | H | 47 | 4 | 1.9 | 5 | 3 |
| TLC476M004#TA | 0603 | 1608-10 | L | 47 | 4 | 1.9 | 7.5 | 3 |
| TLCR686M004#TA | 0805 | 2012-15 | R | 68 | 4 | 2.7 | 5 | 3 |
| TLC107M004#TA | 1205 | 3216-10 | C | 100 | 4 | 4.0 | 2 | 3 |
| TLCH107M004#TA | 0805 | 2012-10 | H | 100 | 4 | 4.0 | 5 | 3 |
| TLCQ107M004#TA | 0805 | 2012-12 | Q | 100 | 4 | 4.0 | 5 | 3 |
| TLCR107M004#TA | 0805 | 2012-15 | R | 100 | 4 | 4.0 | 5 | 3 |
| TLCR157M004#TA | 0805 | 2012-15 | R | 150 | 4 | 6.0 | 5 | 3 |
| TLCR227M004#TA | 1206 | 3216-18 | A | 220 | 4 | 8.8 | 1 | 3 |
| TLCR227M004#TA | 0805 | 2012-15 | R | 220 | 4 | 8.8 | 5 | 3 |
| TLC227M004#TA | 1210 | 3528-12 | T | 220 | 4 | 8.8 | 1 | 3 |
| TLCA477M004#TA | 1206 | 3216-18 | A | 470 | 4 | 18.8 | 1 | 3 |
| 6.3 Volt @ 40°C (3.2 Volt @ 85°C, 1.3 Volt @ 125°C) | | | | | | | | |
| TLC475M006#TA | 0402 | 1005-07 | K | 4.7 | 6.3 | 0.5 | 15 | 3 |
| TLCU475M006#TA | 0805 | 2012-06 | U | 4.7 | 6.3 | 0.5 | 5 | 3 |
| TLCJ106M006#TA | 0603 | 1608-08 | J | 10 | 6.3 | 0.6 | 7.5 | 3 |
| TLC106M006#TA | 0402 | 1005-07 | K | 10 | 6.3 | 3.1 | 15 | 3 |
| TLCZ106M006#TA | 0602 | 1605-07 | Z | 10 | 6.3 | 0.6 | 15 | 3 |
| TLC1226M006#TA | 0603 | 1608-10 | L | 22 | 6.3 | 1.4 | 7.5 | 3 |
| TLCU226M006#TA | 0805 | 2012-06 | U | 22 | 6.3 | 2.8 | 12 | 3 |
| TLC336M006#TA | 0805 | 2012-10 | H | 33 | 6.3 | 2.0 | 5 | 3 |
| TLC1336M006#TA | 0603 | 1608-10 | L | 33 | 6.3 | 2.1 | 7.5 | 3 |
| TLC1336M006#4000 | 0603 | 1608-10 | L | 33 | 6.3 | 2.1 | 4 | 3 |
| TLCU336M006#TA | 0805 | 2012-06 | U | 33 | 6.3 | 10.4 | 7.5 | 3 |
| TLCV336M006#TA | 1206 | 3216-08 | V | 33 | 6.3 | 4.2 | 5 | 3 |
| TLC476M006#TA | 0805 | 2012-10 | H | 47 | 6.3 | 3.0 | 5 | 3 |
| TLCV476M006#TA | 1206 | 3216-08 | V | 47 | 6.3 | 6.0 | 15 | 3 |
| TLCR686M006#TA | 0805 | 2012-15 | R | 68 | 6.3 | 4.3 | 5 | 3 |
| TLCR107M006#TA | 0805 | 2012-15 | R | 100 | 6.3 | 6.0 | 5 | 3 |
| TLCR157M006#TA | 0805 | 2012-15 | R | 150 | 6.3 | 9.5 | 5 | 3 |

| AVX Part No. | EIA Code | EIA Metric | Case Size | Cap (µF) | Rated Voltage (V) | DCL (µA) Max. | ESR Max. (Ω) @100kHz | MSL |
|--|----------|------------|-----------|----------|-------------------|---------------|----------------------|-----|
| 8 Volt @ 40°C (4 Volt @ 85°C, 1.6 Volt @ 125°C) | | | | | | | | |
| TLC1336M008#TA | 0603 | 1608-08 | L | 33 | 8 | 26.4 | 10 | 3 |
| 10 Volt @ 40°C (5 Volt @ 85°C, 2 Volt @ 125°C) | | | | | | | | |
| TLCN474M010#TA | 0402 | 1005-05 | N | 0.47 | 10 | 0.5 | 20 | 3 |
| TLCJ225M010#TA | 0603 | 1608-08 | J | 2.2 | 10 | 0.5 | 7.5 | 3 |
| TLCCK225M010#TA | 0402 | 1005-07 | K | 2.2 | 10 | 0.5 | 15 | 3 |
| TLCJ475M010#TA | 0603 | 1608-08 | J | 4.7 | 10 | 0.5 | 10 | 3 |
| TLCCK475M010#TA | 0402 | 1005-07 | K | 4.7 | 10 | 0.5 | 15 | 3 |
| TLCU685M010#TA | 0805 | 2012-06 | U | 6.8 | 10 | 0.7 | 5 | 3 |
| TLCJ106M010#TA | 0603 | 1608-08 | J | 10 | 10 | 1.0 | 7.5 | 3 |
| TLCU106M010#TA | 0805 | 2012-06 | U | 10 | 10 | 1.0 | 5 | 3 |
| TLCZ106M010#TA | 0602 | 1605-07 | Z | 10 | 10 | 1.0 | 15 | 3 |
| TLCH156M010#TA | 0805 | 2012-10 | H | 15 | 10 | 1.5 | 5 | 3 |
| TLC156M010#TA | 0603 | 1608-08 | L | 15 | 10 | 1.5 | 7.5 | 3 |
| TLC1226M010#TA | 0603 | 1608-10 | L | 22 | 10 | 1.1 | 10 | 3 |
| TLCM226M010#TA | 0803 | 2008-10 | M | 22 | 10 | 2.2 | 7.5 | 3 |
| TLCJ475M010#TA | 0805 | 2012-10 | H | 33 | 10 | 3.3 | 5 | 3 |
| TLC476M010#TA | 1205 | 3216-10 | C | 47 | 10 | 4.7 | 2 | 3 |
| TLCQ476M010#TA | 0805 | 2012-12 | Q | 47 | 10 | 4.7 | 5 | 3 |
| TLCR476M010#TA | 0805 | 2012-15 | R | 47 | 10 | 4.7 | 5 | 3 |
| TLC686M010#TA | 1206 | 3216-18 | A | 68 | 10 | 6.8 | 1 | 3 |
| TLCR686M010#TA | 0805 | 2012-15 | R | 68 | 10 | 6.8 | 5 | 3 |
| TLCR107M010#TA | 0805 | 2012-15 | R | 100 | 10 | 10 | 5 | 3 |
| TLC107M010#TA | 1210 | 3528-12 | T | 100 | 10 | 10 | 1 | 3 |
| 16 Volt @ 40°C (8 Volt @ 85°C, 3.2 Volt @ 125°C) | | | | | | | | |
| TLCJ334M016#TA | 0603 | 1608-08 | J | 0.33 | 16 | 0.5 | 7.5 | 3 |
| TLC474M016#TA | 0402 | 1005-07 | K | 0.47 | 16 | 0.5 | 15 | 3 |
| TLCJ105M016#TA | 0603 | 1608-08 | J | 1.0 | 16 | 0.5 | 7.5 | 3 |
| TLC105M016#TA | 0402 | 1005-07 | K | 1 | 16 | 0.8 | 15 | 3 |
| TLCJ225M016#TA | 0603 | 1608-08 | J | 2.2 | 16 | 0.5 | 7.5 | 3 |
| TLC1335M016#TA | 0603 | 1608-10 | L | 3.3 | 16 | 0.5 | 7.5 | 3 |
| TLCV106M016#TA | 1206 | 3216-08 | V | 10 | 16 | 1.6 | 2 | 3 |
| 20 Volt @ 40°C (10 Volt @ 85°C, 4 Volt @ 125°C) | | | | | | | | |
| TLCJ105M020#TA | 0603 | 1608-08 | J | 1.0 | 20 | 0.5 | 7.5 | 3 |
| TLC225M020#TA | 0805 | 2012-10 | H | 2.2 | 20 | 0.5 | 5 | 3 |
| TLC1225M020#TA | 0603 | 1608-10 | L | 2.2 | 20 | 0.5 | 7.5 | 3 |
| TLCR106M020#TA | 0805 | 2012-15 | R | 10 | 20 | 2.0 | 5 | 3 |
| 25 Volt @ 40°C (12.5 Volt @ 85°C, 5 Volt @ 125°C) | | | | | | | | |
| TLC1334M025#TA | 0603 | 1608-10 | L | 0.33 | 25 | 0.5 | 7.5 | 3 |
| TLC105M025#TA | 0603 | 1608-10 | L | 1.0 | 25 | 0.5 | 7.5 | 3 |
| TLC225M025#TA | 0805 | 2012-10 | H | 2.2 | 25 | 0.6 | 5 | 3 |
| TLCR225M025#TA | 0805 | 2012-15 | R | 2.2 | 25 | 0.6 | 5 | 3 |
| TLC226M025#TA | 1210 | 3528-12 | T | 22 | 25 | 5.5 | 1 | 3 |
| 35 Volt @ 40°C (17.5 Volt @ 85°C, 7 Volt @ 125°C) | | | | | | | | |
| TLC105M035#TA | 0603 | 1608-10 | L | 1.0 | 35 | 0.5 | 7.5 | 3 |
| TLCR105M035#TA | 0805 | 2012-15 | R | 1.0 | 35 | 0.5 | 5 | 3 |
| TLCR475M035#TA | 0805 | 2012-15 | R | 4.7 | 35 | 1.6 | 5 | 3 |
| TLC106M035#TA | 1206 | 3216-18 | A | 10 | 35 | 3.5 | 1 | 3 |

Moisture Sensitivity Level (MSL) is defined according to J-STD-020.
All technical data relates to an ambient temperature of +25°C. Capacitance and DF are measured at 120Hz, 0.5V RMS with a maximum DC bias of 2.2 volts. DCL is measured at rated voltage after 5 minutes.
DCL allowed to move up to 2.00 times the limit post mounting.
ESR allowed to move up to 1.25 times the limit post mounting.
For typical weight and composition see page 144.

NOTE: AVX reserves the right to supply a higher voltage rating or tighter tolerance part in the same case size, to the same reliability standards.

Voltage vs Temperature Rating

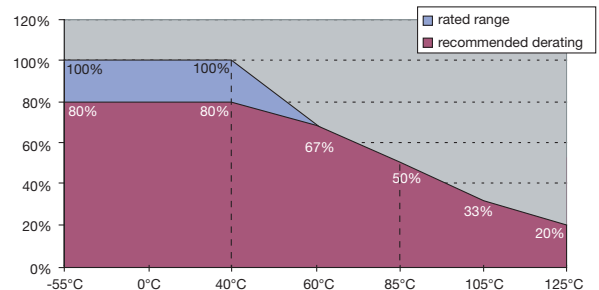

TLN Series



Tantalum Solid Electrolytic Chip Capacitors Undertab Series



- Undertab terminations layout:
 - High Volumetric Efficiency
 - High PCB assembly density
 - High capacitance in smaller dimensions
- 3x reflow 260°C compatible
- Consumer applications (e.g. PCMCIA/USB wireless express cards, mobiles, MP3 etc.)
- 7 case sizes available
- CV range: 47-1000µF / 4-10V



CASE DIMENSIONS: millimeters (inches)

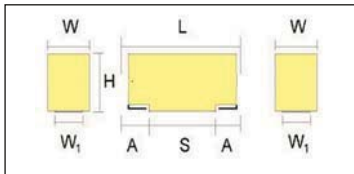

For part marking see page 151

| Code | EIA Code | EIA Metric | L±0.20 (0.008) | W+0.20 (0.008) -0.10 (0.004) | H max. | W1±0.20 (0.008) | A+0.30 (0.012) -0.20 (0.008) |
|------|----------|------------|----------------|---------------------------------|--------------|-----------------|---------------------------------|
| G | 1206 | 3216-15 | 3.20 (0.126) | 1.60 (0.063) | 1.50 (0.059) | 1.20 (0.047) | 0.80 (0.031) |
| K | 1206 | 3216-10 | 3.20 (0.126) | 1.60 (0.063) | 1.00 (0.039) | 1.20 (0.047) | 0.80 (0.031) |
| L | 1210 | 3528-10 | 3.50 (0.138) | 2.80 (0.110) | 1.00 (0.039) | 2.20 (0.087) | 0.80 (0.031) |
| M | 0805 | 2012-09 | 2.05 (0.081) | 1.30 (0.051) | 0.90 (0.035) | 1.00 (0.039) | 0.80 (0.031) |
| N | 0805 | 2012-10 | 2.05 (0.081) | 1.30 (0.051) | 1.00 (0.039) | 1.00 (0.039) | 0.50 (0.020) |
| S | 1206 | 3216-12 | 3.20 (0.126) | 1.60 (0.063) | 1.20 (0.047) | 1.20 (0.047) | 0.80 (0.031) |
| T | 1210 | 3528-12 | 3.50 (0.138) | 2.80 (0.110) | 1.20 (0.047) | 2.20 (0.087) | 0.80 (0.031) |
| Y | 2917 | 7343-20 | 7.30 (0.287) | 4.30 (0.169) | 2.00 (0.079) | 2.40 (0.094) | 1.30 (0.051) |

W1 dimension applies to the termination width for A dimensional area only.

Under development

HOW TO ORDER

TLN

Type

S

Case Size
See table above

227

Capacitance Code
pF code: 1st two digits represent significant figures, 3rd digit represents multiplier (number of zeros to follow)

M

Tolerance
M = ±20%

004

Rated DC Voltage
004 = 4Vdc
006 = 6.3Vdc
010 = 10Vdc

R

Packaging
R = Pure Tin 7" Reel
S = Pure Tin 13" Reel

3000

ESR in mΩ

TECHNICAL SPECIFICATIONS

| | | | | | |
|------------------------------------|--|-----|------|----|--|
| Technical Data: | All technical data relate to an ambient temperature of +25°C | | | | |
| Capacitance Range: | 47 µF to 1000 µF | | | | |
| Capacitance Tolerance: | ±20% | | | | |
| Rated Voltage (V _R) | -55°C ≤ +40°C: | 4 | 6.3 | 10 | |
| Category Voltage (V _C) | at 85°C: | 2 | 3.15 | 5 | |
| Category Voltage (V _C) | at 125°C: | 0.8 | 1.26 | 2 | |
| Temperature Range: | -55°C to +125°C with category voltage | | | | |
| Reliability: | 0.2% per 1000 hours at 85°C, 0.5xV _R with 0.1Ω/V series impedance with 60% confidence level | | | | |

TLN Series



Tantalum Solid Electrolytic Chip Capacitors Undertab Series

CAPACITANCE AND RATED VOLTAGE, VR (VOLTAGE CODE) RANGE (LETTER DENOTES CASE SIZE)

| Capacitance | | Rated Voltage DC to 40°C / 0.5DC to 85°C/ 0.2DC to 125°C | | |
|-------------|------|--|-----------------------------|------------------------------------|
| µF | Code | 4V (G) | 6.3V (J) | 10V (A) |
| 33 | 336 | | | |
| 47 | 476 | | | K(1500)/M(6000)/N(6000) |
| 68 | 686 | N(3000)* | K(5400) | K(5400)/S(6000) |
| 100 | 107 | N(5200) | K(2000,5400)/S(5400) | K(2500)/L(7200)* S(2500) |
| 150 | 157 | K(2500)/S(2500) | K(2500)/L(5400)* S(2500) | H(6000)/(1300)/ S(7200)*T(1500) |
| 220 | 227 | K(2500)/L(1300) S(3000)/T(1500) | L(1000) S(8300)*T(1500) | G(7200)*H(6000)* T(1300) |
| 330 | 337 | G(4000)*L(4000)* S(5200)* | G(5400)*H(3000)* | H(7200)*T(9600)* |
| 470 | 477 | G(5200)*H(3000)* T(4000)* | H(5400)*T(8300)* | H(9600)* |
| 680 | 687 | H(4000)*T(5200)* | H(8300)* | |
| 1000 | 108 | H(5200)* | Y(150) | |

Available Ratings, (ESR ratings in mOhms in brackets)

Engineering samples - please contact manufacturer

*Codes under development - subject to change

Note: Voltage ratings are minimum values. AVX reserves the right to supply higher ratings in the same case size, to the same reliability standards.

RATINGS & PART NUMBER REFERENCE

| AVX Part No. | Case Size | Capacitance (µF) | Rated Voltage (V) | Maximum Surge Current (A)* | DCL (µA) Max. | ESR Max. (mΩ) @100kHz | MSL | 100kHz Ripple Current (mA) | | | 100kHz Ripple Voltage (mV) | | |
|--|-----------|------------------|-------------------|----------------------------|---------------|-----------------------|-----|----------------------------|------|-------|----------------------------|------|-------|
| | | | | | | | | 25°C | 85°C | 125°C | 25°C | 85°C | 125°C |
| 4 Volt @ 40°C (2 Volt @ 85°C, 0.8 Volt @ 125°C) | | | | | | | | | | | | | |
| TLNN107M004#5200 | N | 100 | 4 | 0.4 | 20 | 5200 | 3 | 88 | 79 | 35 | 456 | 410 | 182 |
| TLNK157M004#2500 | K | 150 | 4 | 0.7 | 12 | 2500 | 3 | 148 | 133 | 59 | 371 | 334 | 148 |
| TLNS157M004#2500 | S | 150 | 4 | 0.7 | 12 | 2500 | 3 | 148 | 133 | 59 | 371 | 334 | 148 |
| TLNK227M004#2500 | K | 220 | 4 | 0.7 | 44 | 2500 | 3 | 148 | 133 | 59 | 371 | 334 | 148 |
| TLNL227M004#1300 | L | 220 | 4 | 1.1 | 17.6 | 1300 | 3 | 215 | 193 | 86 | 279 | 251 | 112 |
| TLNS227M004#3000 | S | 220 | 4 | 0.6 | 17.6 | 3000 | 3 | 135 | 122 | 54 | 406 | 366 | 162 |
| TLNT227M004#1500 | T | 220 | 4 | 1.0 | 17.6 | 1500 | 3 | 216 | 194 | 86 | 324 | 292 | 130 |
| 6.3 Volt @ 40°C (3.15 Volt @ 85°C, 1.26 Volt @ 125°C) | | | | | | | | | | | | | |
| TLNK686M006#5400 | K | 68 | 6.3 | 0.5 | 4.1 | 5400 | 3 | 101 | 91 | 40 | 545 | 490 | 218 |
| TLNK107M006#2000 | K | 100 | 6.3 | 1.3 | 12 | 2000 | 3 | 166 | 149 | 66 | 332 | 298 | 133 |
| TLNK107M006#5400 | K | 100 | 6.3 | 0.5 | 6 | 5400 | 3 | 101 | 91 | 40 | 545 | 490 | 218 |
| TLNS107M006#5400 | S | 100 | 6.3 | 0.5 | 6 | 5400 | 3 | 101 | 91 | 40 | 545 | 490 | 218 |
| TLNK157M006#2500 | K | 150 | 6.3 | 1.1 | 18 | 2500 | 3 | 148 | 133 | 59 | 371 | 334 | 148 |
| TLNS157M006#2500 | S | 150 | 6.3 | 1.1 | 18 | 2500 | 3 | 148 | 133 | 59 | 371 | 334 | 148 |
| TLNL227M006#1000 | L | 220 | 6.3 | 2.2 | 26.4 | 1000 | 3 | 245 | 220 | 98 | 245 | 220 | 98 |
| TLNT227M006#1500 | T | 220 | 6.3 | 1.6 | 26.4 | 1500 | 3 | 216 | 194 | 86 | 324 | 292 | 130 |
| TLNY108M006#0150 | Y | 1000 | 6.3 | 5.3 | 63 | 150 | 3 | 876 | 788 | 350 | 131 | 118 | 53 |
| 10 Volt @ 40°C (5 Volt @ 85°C, 2 Volt @ 125°C) | | | | | | | | | | | | | |
| TLNK476M010#1500 | K | 47 | 10 | 2.6 | 4.7 | 1500 | 3 | 191 | 172 | 77 | 287 | 259 | 115 |
| TLNM476M010#6000 | M | 47 | 10 | 0.8 | 9.4 | 6000 | 3 | 82 | 73 | 33 | 490 | 441 | 196 |
| TLNN476M010#6000 | N | 47 | 10 | 0.8 | 9.4 | 6000 | 3 | 82 | 73 | 33 | 490 | 441 | 196 |
| TLNK686M010#5400 | K | 68 | 10 | 0.9 | 6.8 | 5400 | 3 | 101 | 91 | 40 | 545 | 490 | 218 |
| TLNS686M010#6000 | S | 68 | 10 | 0.8 | 6.8 | 6000 | 3 | 96 | 86 | 38 | 574 | 517 | 230 |
| TLNK107M010#2500 | K | 100 | 10 | 1.7 | 20 | 2500 | 3 | 148 | 133 | 59 | 371 | 334 | 148 |
| TLNS107M010#2500 | S | 100 | 10 | 1.7 | 10 | 2500 | 3 | 148 | 133 | 59 | 371 | 334 | 148 |
| TLNH157M010#6000 | H | 150 | 10 | 0.8 | 30 | 6000 | 3 | 108 | 97 | 43 | 648 | 583 | 259 |
| TLNL157M010#1300 | L | 150 | 10 | 2.9 | 30 | 1300 | 3 | 215 | 193 | 86 | 279 | 251 | 112 |
| TLNT157M010#1500 | T | 150 | 10 | 2.6 | 30 | 1500 | 3 | 216 | 194 | 86 | 324 | 292 | 130 |
| TLNT227M010#1300 | T | 220 | 10 | 2.9 | 44 | 1300 | 3 | 232 | 209 | 93 | 302 | 271 | 121 |

Moisture Sensitivity Level (MSL) is defined according to J-STD-020.

All technical data relates to an ambient temperature of +25°C. Capacitance and DF are measured at 120Hz, 0.5V RMS with a maximum DC bias of 2.2 volts. DCL is measured at rated voltage after 5 minutes.

ESR allowed to move up to 1.25 times catalogue limit post mounting

DCL allowed to move up to 2.00 times catalogue limit post mounting

For typical weight and composition see page 144.

NOTE: AVX reserves the right to supply a higher voltage rating or tighter tolerance part in the same case size, to the same reliability standards.

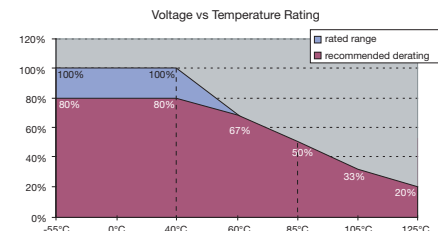

TLN PulseCap™ Series



Tantalum Solid Electrolytic Chip Capacitors Undertab Series



- Large case size for maximum capacitance
- 3x reflow 260°C compatible
- Low profile solution
- Consumer applications (e.g. PCMCIA/USB wireless express cards etc.)
- CV range: 1000-3300µF / 4-10V
- 2 case sizes available



LEAD-FREE
LEAD-FREE COMPATIBLE
COMPONENT



RoHS
COMPLIANT

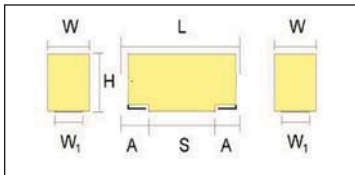

For part marking see page 151

CASE DIMENSIONS: millimeters (inches)

| Code | EIA Code | EIA Metric | L+0.50 (0.020) -0.00 (0.000) | W+0.20 (0.008) -0.10 (0.004) | H max. | W ₁ ±0.20 (0.008) | A+0.30 (0.012) -0.20 (0.008) |
|------|----------|------------|---------------------------------|---|--------------|---------------------------------|---------------------------------|
| 4 | 2924 | 7361-20 | 7.30 (0.287) | 6.10 (0.240) | 2.00 (0.079) | 4.75 (0.187) | 2.00 (0.079) |
| 6 | 6030 | 15075-20 | 14.50 (0.571) | 7.50 ^{+0.50} -0.00 (0.295 ^{+0.020} -0.000) | 2.00 (0.079) | 5.50 (0.217) | 2.40 (0.094) |

W1 dimension applies to the termination width for A dimensional area only.

HOW TO ORDER

TLN



Type

6



Case Size
See table
above

228



Capacitance Code
pF code: 1st two digits
represent significant figures,
3rd digit represents multiplier

M



Tolerance
M = ±20%

006



Rated DC Voltage
004 = 4Vdc
006 = 6.3Vdc
010 = 10Vdc

R



Packaging
R = Pure Tin 7" Reel

0055



ESR in mΩ

TECHNICAL SPECIFICATIONS

| | | | | | |
|------------------------------------|--|-----|------|----|--|
| Technical Data: | All technical data relate to an ambient temperature of +25°C | | | | |
| Capacitance Range: | 1000 µF to 3300 µF | | | | |
| Capacitance Tolerance: | ±20% | | | | |
| Leakage Current DCL: | 0.01CV | | | | |
| Rated Voltage (V _R) | -55°C ≤ +40°C: | 4 | 6.3 | 10 | |
| Category Voltage (V _C) | at 85°C: | 2 | 3.15 | 5 | |
| Category Voltage (V _C) | at 125°C: | 0.8 | 1.26 | 2 | |
| Temperature Range: | -55°C to +125°C with category voltage | | | | |
| Reliability: | 0.2% per 1000 hours at 85°C, 0.5xV _R with 0.1Ω/V series impedance with 60% confidence level | | | | |

TLN PulseCap™ Series



Tantalum Solid Electrolytic Chip Capacitors Undertab Series

CAPACITANCE AND RATED VOLTAGE, VR (VOLTAGE CODE) RANGE (FIGURE DENOTES CASE SIZE)

| Capacitance | | Voltage Rating DC (V _R) to 85°C | | |
|-------------|------|---|----------|--------------|
| µF | Code | 4V (G) | 6.3V (J) | 10V (A) |
| 680 | 687 | | | |
| 1000 | 108 | | | 4(100)/6(55) |
| 1500 | 158 | | 4(100) | 6(55) |
| 2200 | 228 | | 6(55) | |
| 3300 | 338 | 6(55) | 6* | |

Available Codes (ESR ratings in mOhms in brackets)

Engineering samples - please contact manufacturer

*Codes under development – subject to change

Note: Voltage ratings are minimum values. AVX reserves the right to supply higher ratings in the same case size, to the same reliability standards.

RATINGS & PART NUMBER REFERENCE

| AVX Part No. | Case Size | Cap (µF) | Rated Voltage (V) | DCL (µA) Max. | ESR Max. (mΩ) @100kHz | MSL | 100kHz Ripple Current (mA) | | | 100kHz Ripple Voltage (mV) | | | |
|--|-----------|----------|-------------------|---------------|-----------------------|-----|----------------------------|------|-------|----------------------------|------|-------|--|
| | | | | | | | 25°C | 85°C | 125°C | 25°C | 85°C | 125°C | |
| 4 Volt @ 40°C (2 Volt @ 85°C, 0.8 Volt @ 125°C) | | | | | | | | | | | | | |
| TLN6338M004#0055 | 6 | 3300 | 4 | 132 | 55 | 3 | 2045 | 1840 | 818 | 112 | 101 | 45 | |
| 6.3 Volt @ 40°C (3.15 Volt @ 85°C, 1.26 Volt @ 125°C) | | | | | | | | | | | | | |
| TLN4158M006#0100 | 4 | 1500 | 6.3 | 90 | 100 | 3 | 1285 | 1156 | 514 | 128 | 116 | 51 | |
| TLN6228M006#0055 | 6 | 2200 | 6.3 | 132 | 55 | 3 | 2045 | 1840 | 818 | 112 | 101 | 45 | |
| 10 Volt @ 40°C (5 Volt @ 85°C, 2 Volt @ 125°C) | | | | | | | | | | | | | |
| TLN4108M010#0100 | 4 | 1000 | 10 | 100 | 100 | 3 | 1285 | 1156 | 514 | 128 | 116 | 51 | |
| TLN6108M010#0055 | 6 | 1000 | 10 | 100 | 55 | 3 | 2045 | 1840 | 818 | 112 | 101 | 45 | |
| TLN6158M010#0055 | 6 | 1500 | 10 | 150 | 55 | 3 | 2045 | 1840 | 818 | 112 | 101 | 45 | |

Moisture Sensitivity Level (MSL) is defined according to J-STD-020.

All technical data relates to an ambient temperature of +25°C. Capacitance and DF are measured at 120Hz, 0.5V RMS with a maximum DC bias of 2.2 volts. DCL is measured at rated voltage after 5 minutes.

ESR allowed to move up to 1.25 times catalogue limit post mounting

DCL allowed to move up to 2.00 times catalogue limit post mounting

For typical weight and composition see page 144.

NOTE: AVX reserves the right to supply a higher voltage rating or tighter tolerance part in the same case size, to the same reliability standards.

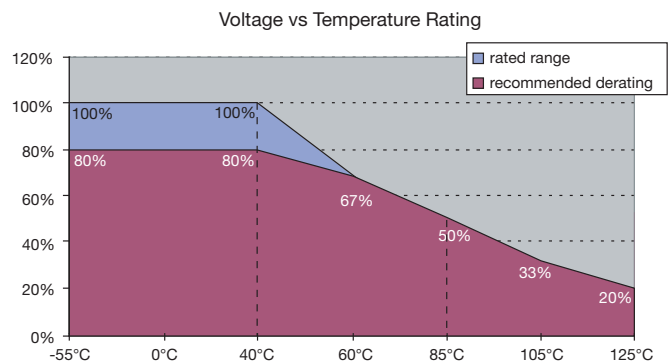

F98 Series



Resin-Molded Chip, High CV Frameless®

FRAMELESS™

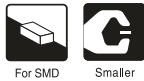

Upgrade

- Compliant to the RoHS directive (2002/95/EC).

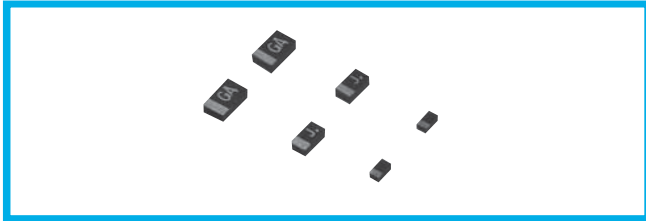

Applications

- Smartphone
- Wireless module
- Mobile phone
- Hearing aid

Type numbering system (Example : 6.3V 10µF)

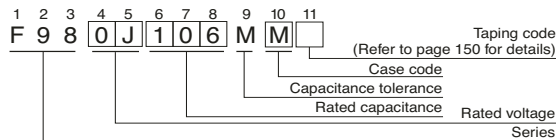

Drawing

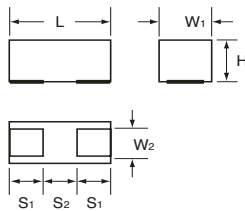

(mm)

| Case Code | L | W ₁ | W ₂ | H | S ₁ | S ₂ |
|-----------|-------------------------------------|--------------------------------------|----------------|-------------|----------------|----------------|
| U | 1.10 ± 0.05 | 0.60 ± 0.05 | 0.35 ± 0.05 | 0.55 ± 0.05 | 0.3 ± 0.05 | 0.5 ± 0.05 |
| M | 1.6 ^{+0.2} _{-0.1} | 0.85 ^{+0.2} _{-0.1} | 0.65 ± 0.1 | 0.8 ± 0.1 | 0.5 ± 0.1 | 0.6 ± 0.1 |
| S | 2.0 ^{+0.2} _{-0.1} | 1.25 ^{+0.2} _{-0.1} | 0.9 ± 0.1 | 0.8 ± 0.1 | 0.5 ± 0.1 | 1.0 ± 0.1 |

Marking

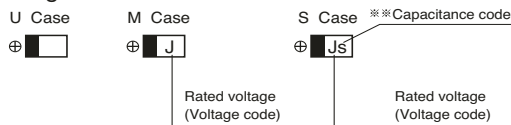

Standard Ratings

| Cap. (µF) | Code | V | | | | | | Capacitance code |
|-----------|------|-------|---------|---------|----|----|----|------------------|
| | | 4 | 6.3 | 10 | 16 | 20 | 25 | |
| 1 | 105 | | | | M | M | M | — |
| 2.2 | 225 | | | U · M | M | | | — |
| 4.7 | 475 | U | U · M | (U) · M | M | | | — |
| 10 | 106 | U | (U) · M | M | S | | | a |
| 22 | 226 | M | M | (M) · S | | | | J |
| 33 | 336 | M | M | (M) · S | | | | n |
| 47 | 476 | M | M · S | S | | | | s |
| 68 | 686 | M · S | | | | | | w |
| 100 | 107 | M · S | S | | | | | A |
| 220 | 227 | S | | | | | | J |

() The series in parentheses are being developed. Please contact to your local AVX sales office when these series are being designed in your application.

We can consider the type of compliance to AEC-Q200. Please contact to your local AVX sales office when these series are being designed in your application.

Specifications

| Item | Performance Characteristics |
|------------------------------|---|
| Category | —55 to +125°C (Rated temperature : +85°C) |
| Temperature Range | |
| Capacitance Tolerance | ±20% (at 120Hz) |
| Dissipation Factor | Refer to the table below |
| ESR | Refer to the table below |
| Leakage Current | Refer to the table below Provided that • After 5 minute's application of rated voltage, leakage current at 85°C, 10 times or less than 20°C specified value. • After 5 minute's application of rated voltage, leakage current at 125°C, 12.5 times or less than 20°C specified value. |
| Damp Heat (Steady State) | At 40°C, 90 to 95% R.H., For 500hours (No voltage applied) Capacitance Change . . . Refer to the table below (* 1) Dissipation Factor 150% or less of initial specified value Leakage Current 200% or less of initial specified value |
| Temperature Cycles | At -55°C / +125°C, For 30 minutes each, 5 cycles Capacitance Change . . . Refer to the table below (* 1) Dissipation Factor 150% or less than the initial specified value Leakage Current Initial specified value or less |
| Resistance to Soldering Heat | 10 seconds reflow at 260°C, 5 seconds immersion at 260°C Capacitance Change . . . Refer to the table below (* 1) Leakage Current Initial specified value or less Leakage Current Initial specified value or less |
| Surge | After application of surge in series with a 1kΩ resistor at the rate of 30 seconds ON, 30 seconds OFF, for 1000 successive test cycles at 85°C, capacitors shall meet the characteristic requirements listed below. Capacitance Change . . . Refer to the table below (* 1) Dissipation Factor 150% or less than the initial specified value Leakage Current 200% or less than the initial specified value |
| Endurance | After 1000 hours' application of rated voltage in series with a 3Ω resistor at 85°C, capacitors shall meet the characteristic requirements table below Capacitance Change . . . Refer to the table below (* 1) Dissipation Factor 150% or less than the initial specified value Leakage Current 200% or less than the initial specified value |
| Shear Test | After applying the pressure load of 5N for 10±1 seconds horizontally to the center of capacitor side body which has no electrode and has been soldered beforehand on a substrate, there shall be found neither exfoliation nor its sign at the terminal electrode. For 10 ± 1 seconds |
| Terminal Strength | Keeping a capacitor surface-mounted on a substrate upside down and supporting the substrate at both of the opposite bottom points 45mm apart from the center of capacitor, the pressure strength is applied with a specified jig at the center of the substrate so that substrate may bend by 1mm as illustrated. Then, there shall be found no remarkable abnormality on the capacitor terminals. |

| Rated Volt | Rated Capacitance (µF) | Case code | Part Number | *2 Leakage Current (µA) | Dissipation Factor (% @ 120kHz) | ESR (Ω @ 100kHz) | *1 Δ/C (%) |
|------------|------------------------|-------------|-------------|-------------------------|---------------------------------|------------------|------------|
| 4V | 4.7 | U | F980G475MUA | 0.5 | 20 | 20 | ±30 |
| | 10 | U | F980G106MUA | 0.8 | 25 | 20 | ±30 |
| | 22 | M | F980G226MMA | 0.9 | 15 | 7.5 | ±30 |
| | 33 | M | F980G336MMA | 1.3 | 30 | 4 | ±30 |
| | 47 | M | F980G476MMA | 1.9 | 40 | 8 | ±30 |
| | 68 | M | F980G686MMA | 27.2 | 50 | 10 | ±30 |
| | 68 | S | F980G686MSA | 2.7 | 30 | 4 | ±30 |
| | 100 | M | F980G107MMA | 80.0 | 60 | 10 | ±30 |
| | 100 | S | F980G107MSA | 4.0 | 35 | 4 | ±30 |
| | 220 | S | F980G227MSA | 132 | 80 | 5 | ±30 |
| 6.3V | 4.7 | U | F980J475MUA | 0.6 | 20 | 20 | ±30 |
| | 4.7 | M | F980J475MMA | 0.5 | 20 | 7.5 | ±30 |
| | 10 | M | F980J106MMA | 0.6 | 8 | 6 | ±30 |
| | 22 | M | F980J226MMA | 1.4 | 20 | 6 | ±30 |
| | 33 | M | F980J336MMA | 4.2 | 35 | 8 | ±30 |
| | 47 | M | F980J476MMA | 29.6 | 45 | 10 | ±30 |
| | 47 | S | F980J476MSA | 3.0 | 25 | 6 | ±30 |
| 100 | S | F980J107MSA | 63.0 | 50 | 8 | ±30 | |
| 10V | 2.2 | U | F981A225MUA | 0.5 | 15 | 15 | ±30 |
| | 2.2 | M | F981A225MMA | 0.5 | 6 | 7.5 | ±30 |
| | 4.7 | M | F981A475MMA | 0.5 | 6 | 6 | ±30 |
| | 10 | M | F981A106MMA | 1.0 | 20 | 7.5 | ±30 |
| | 22 | S | F981A226MSA | 2.2 | 20 | 4 | ±20 |
| | 33 | S | F981A336MSA | 3.3 | 30 | 6 | ±30 |
| | 47 | S | F981A476MSA | 9.4 | 35 | 5 | ±30 |
| 16V | 1 | M | F981C105MMA | 0.5 | 6 | 10 | ±30 |
| | 2.2 | M | F981C225MMA | 0.5 | 6 | 10 | ±30 |
| | 4.7 | M | F981C475MMA | 0.8 | 12 | 12 | ±30 |
| | 10 | S | F981C106MSA | 1.6 | 18 | 4 | ±20 |
| 20V | 1 | M | F981D105MMA | 0.5 | 6 | 10 | ±30 |
| 25V | 1 | M | F981E105MMA | 0.5 | 8 | 10 | ±30 |

*2 : Leakage Current
After 5 minute's application of rated voltage, leakage current at 20°C.



F72/F75 Series



Low Profile and HiCV Conformal Coated Chip

FRAMELESS™



Upgrade

● Compliant to the RoHS directive (2002/95/EC).



Applications

- Wireless modem
- Tablet PC
- e-book
- SSD
- Smart meter

F72

Type numbering system (Example: 10V 100μF)

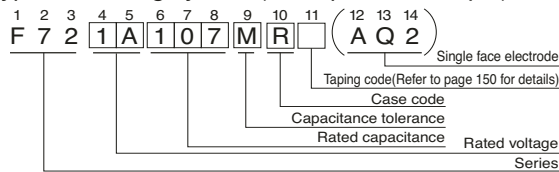

Drawing

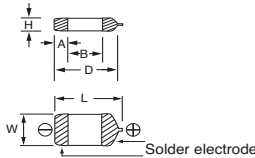

Dimensions

| Case code | L | W | H | A | B | (D) |
|-----------|-----------|-----------|-----------|-----------|-----------|-------|
| R | 7.2 ± 0.3 | 6.0 ± 0.3 | 1.2 ± 0.3 | 1.3 ± 0.4 | 3.8 ± 0.6 | (6.2) |
| M | 7.2 ± 0.3 | 6.0 ± 0.3 | 2.0MAX. | 1.3 ± 0.4 | 3.8 ± 0.6 | (6.2) |

D dimension only for reference

F75

Type numbering system (Example: 16V 150μF)

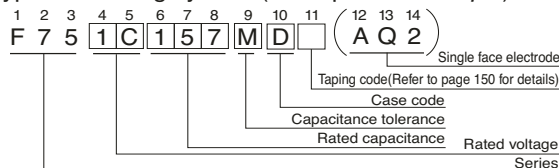

Drawing

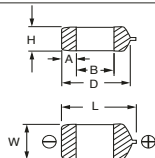

Standard Ratings

F72

| Cap. (μF) | Code | V | | | |
|-----------|------|---|-----|-----|----|
| | | 4 | 6.3 | 10 | 16 |
| 33 | 336 | | | | R |
| 47 | 476 | | | R | R |
| 68 | 686 | | R | R | R |
| 100 | 107 | R | R | R | |
| 150 | 157 | R | R | R | |
| 220 | 227 | R | R | R | |
| 330 | 337 | R | R | (R) | |
| 470 | 477 | | | M | |
| 680 | 687 | | | M | |
| 1000 | 108 | | M | M | |
| 1500 | 158 | | M | | |

() The series in parentheses are being developed. Please contact to your local AVX sales office when these series are being designed in your application.

Specifications

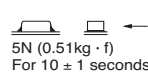
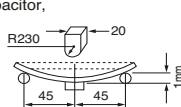
| Item | Performance Characteristics |
|-----------------------------------|--|
| Category | |
| Temperature Range | -55 to +125°C (Rated temperature : +85°C) |
| Capacitance Tolerance | ±20%, ±10% (at 120Hz) |
| Dissipation Factor (120Hz) | Refer to next page |
| ESR (100kHz) | Refer to next page |
| Leakage Current | <ul style="list-style-type: none"> • After 1 minute's application of rated voltage, leakage current at 20°C is not more than 0.01CV or 0.5μA, whichever is greater. • After 1 minute's application of rated voltage, leakage current at 85°C is not more than 0.1CV or 5μA, whichever is greater. • After 1 minute's application of derated voltage, leakage current at 125°C is not more than 0.125CV or 6.3μA, whichever is greater. |
| Capacitance Change by Temperature | +15% Max. (at +125°C) +10% Max. (at +85°C) -10% Max. (at -55°C) |
| Damp Heat (Steady State) | At 40°C, 90 to 95% R.H., For 500 hours (No voltage applied) Capacitance Change Refer to * 1 Dissipation Factor Initial specified value or less Leakage Current Initial specified value or less |
| Temperature Cycles | At -55°C / +125°C, 30 minutes each, For 5 cycles, Capacitance Change Refer to * 1 Dissipation Factor Initial specified value or less Leakage Current Initial specified value or less |
| Resistance to Soldering Heat | 10 seconds reflow at 260°C, 10 seconds immersion at 260°C Capacitance Change Refer to * 1 Dissipation Factor Initial specified value or less Leakage Current Initial specified value or less |
| Surge | After application of surge in series with a 33Ω resistor at the rate of 30 seconds ON, 30 seconds OFF, for 1000 successive test cycles at 85°C, capacitors shall meet the characteristic requirements table below. Capacitance Change Refer to * 1 Dissipation Factor Initial specified value or less Leakage Current Initial specified value or less |
| Endurance | After 2000 hours' application of rated voltage at 85°C, capacitors shall meet the characteristic requirements table below. Capacitance Change Refer to * 1 Dissipation Factor Initial specified value or less Leakage Current Initial specified value or less |
| Shear Test | After applying the pressure load of 5N for 10±1 seconds horizontally to the center of capacitor side body which has no electrode and has been soldered beforehand on a substrate, there shall be found neither exfoliation nor its sign at the terminal electrode.  |
| Terminal Strength | Keeping a capacitor surface-mounted on a substrate upside down and supporting the substrate at both of the opposite bottom points 45mm apart from the center of capacitor, the pressure strength is applied with a specified jig at the center of substrate so that the substrate may bend by 1mm as illustrated. Then, there shall be found no remarkable abnormality on the capacitor terminals.  |

Dimensions

| Case code | L | W | H | A | B | (D) |
|-----------|-----------|-----------|-----------|-----------|-----------|-------|
| U | 7.1 ± 0.3 | 3.2 ± 0.3 | 2.0MAX. | 1.3 ± 0.3 | 3.6 ± 0.6 | (6.0) |
| C | 7.1 ± 0.3 | 3.2 ± 0.3 | 2.5 ± 0.3 | 1.3 ± 0.3 | 3.6 ± 0.6 | (6.0) |
| D | 7.3 ± 0.3 | 4.3 ± 0.3 | 2.8 ± 0.3 | 1.3 ± 0.4 | 3.9 ± 0.6 | (6.4) |
| R | 7.2 ± 0.3 | 6.0 ± 0.3 | 3.5 ± 0.3 | 1.3 ± 0.4 | 3.8 ± 0.6 | (6.2) |

D dimension only for reference

F75

| Cap. (μF) | Code | V | | | |
|-----------|------|-------|-------------|-------|----|
| | | 4 | 6.3 | 10 | 16 |
| 68 | 686 | | | | C |
| 100 | 107 | | | | C |
| 150 | 157 | | | | D |
| 220 | 227 | | C | C · D | R |
| 330 | 337 | C | C · D | D | |
| 470 | 477 | C · D | U · D | U · R | |
| 680 | 687 | D | (U) · D · R | | |
| 1000 | 108 | D · R | (U) · R | | |
| 1500 | 158 | R | | | |
| 2200 | 228 | R | | | |



F72/F75 Series



Low Profile and HiCV Conformal Coated Chip

F72

■ Standard Ratings

| Rated Volt | Rated Capacitance (μF) | Case code | Part Number | Leakage Current (μA) | Dissipation Factor (%@120Hz) | ESR (Ω@100kHz) | *1 ΔC/C (%) |
|------------|------------------------|-------------|-------------|----------------------|------------------------------|----------------|-------------|
| 4V | 100 | R | F720G107MRC | 4.0 | 8 | 0.70 | * |
| | 150 | R | F720G157MRC | 6.0 | 10 | 0.70 | * |
| | 220 | R | F720G227MRC | 8.8 | 12 | 0.70 | * |
| | 330 | R | F720G337MRC | 13.2 | 12 | 0.70 | * |
| 6.3V | 68 | R | F720J686MRC | 4.3 | 6 | 0.75 | * |
| | 100 | R | F720J107MRC | 6.3 | 8 | 0.70 | * |
| | 150 | R | F720J157MRC | 9.5 | 10 | 0.70 | * |
| | 220 | R | F720J227MRC | 13.9 | 12 | 0.70 | * |
| | 330 | R | F720J337MRC | 20.8 | 12 | 0.70 | * |
| | 1000 | M | F720J108MMC | 63.0 | 30 | 0.14 | ±15 |
| 1500 | M | F720J158MMC | 95.0 | 45 | 0.14 | ±20 | |
| 10V | 47 | R | F721A476MRC | 4.7 | 6 | 0.80 | * |
| | 68 | R | F721A686MRC | 6.8 | 6 | 0.75 | * |
| | 100 | R | F721A107MRC | 10.0 | 8 | 0.70 | * |
| | 150 | R | F721A157MRC | 15.0 | 10 | 0.70 | * |
| | 220 | R | F721A227MRC | 22.0 | 12 | 0.70 | * |
| | 470 | M | F721A477MMC | 47.0 | 30 | 0.14 | ±15 |
| | 680 | M | F721A687MMC | 68.0 | 35 | 0.14 | ±20 |
| | 1000 | M | F721A108MMC | 200 | 45 | 0.14 | ±20 |
| 16V | 33 | R | F721C336MRC | 5.3 | 6 | 0.90 | * |
| | 47 | R | F721C476MRC | 7.5 | 6 | 0.80 | * |
| | 68 | R | F721C686MRC | 10.9 | 6 | 0.75 | * |

*1 : ΔC/C Marked "**"

| | F72 ALL Case (%) |
|---------------------------|------------------|
| Damp Heat | ±10 |
| Temperature cycles | ±5 |
| Resistance soldering heat | ±5 |
| Surge | ±5 |
| Endurance | ±10 |

F75

■ Standard Ratings

| Rated Volt | Rated Capacitance (μF) | Case code | Part Number | Leakage Current (μA) | Dissipation Factor (%@120Hz) | ESR (Ω@100kHz) | *1 ΔC/C (%) |
|------------|------------------------|-----------|-------------|----------------------|------------------------------|----------------|-------------|
| 4V | 330 | C | F750G337MCC | 13.2 | 10 | 0.15 | * |
| | 470 | C | F750G477MCC | 18.8 | 14 | 0.12 | * |
| | 470 | D | F750G477MDC | 18.8 | 14 | 0.12 | * |
| | 680 | D | F750G687MDC | 27.2 | 18 | 0.12 | * |
| | 1000 | D | F750G108MDC | 40.0 | 24 | 0.12 | * |
| | 1000 | R | F750G108MRC | 40.0 | 24 | 0.12 | * |
| | 1500 | R | F750G158MRC | 60.0 | 30 | 0.12 | * |
| | 2200 | R | F750G228MRC | 88.0 | 45 | 0.07 | * |
| 6.3V | 220 | C | F750J227MCC | 13.9 | 10 | 0.20 | * |
| | 330 | C | F750J337MCC | 20.8 | 10 | 0.15 | * |
| | 330 | D | F750J337MDC | 20.8 | 10 | 0.15 | * |
| | 470 | U | F750J477MUC | 29.6 | 15 | 0.10 | * |
| | 470 | D | F750J477MDC | 29.6 | 14 | 0.12 | * |
| | 680 | D | F750J687MDC | 42.8 | 18 | 0.12 | * |
| | 680 | R | F750J687MRC | 42.8 | 18 | 0.12 | * |
| | 1000 | R | F750J108MRC | 63.0 | 24 | 0.12 | * |
| 10V | 150 | C | F751A157MCC | 15.0 | 10 | 0.22 | * |
| | 220 | C | F751A227MCC | 22.0 | 10 | 0.20 | * |
| | 220 | D | F751A227MDC | 22.0 | 10 | 0.20 | * |
| | 330 | D | F751A337MDC | 33.0 | 10 | 0.15 | * |
| | 470 | U | F751A477MUC | 94.0 | 30 | 0.15 | ±20 |
| | 470 | R | F751A477MRC | 47.0 | 14 | 0.12 | * |
| 16V | 68 | C | F751C686MCC | 10.9 | 10 | 0.22 | * |
| | 100 | C | F751C107MCC | 16.0 | 10 | 0.22 | * |
| | 150 | D | F751C157MDC | 24.0 | 10 | 0.22 | * |
| | 220 | R | F751C227MRC | 35.2 | 10 | 0.20 | * |

*1 : ΔC/C Marked "**"

| | F75 ALL Case (%) |
|---------------------------|------------------|
| Damp Heat | ±10 |
| Temperature cycles | ±5 |
| Resistance soldering heat | ±5 |
| Surge | ±5 |
| Endurance | ±10 |



TPS Series



Low ESR



- Low ESR series of robust MnO₂ solid electrolyte capacitors
- CV range: 0.15-1500µF / 2.5-50V
- 14 case sizes available
- Power supply applications



LEAD-FREE
LEAD-FREE COMPATIBLE
COMPONENT



SnPb termination option is not
RoHS compliant.

CASE DIMENSIONS: millimeters (inches)

| Code | EIA Code | EIA Metric | L±0.20 (0.008) | W+0.20 (0.008) -0.10 (0.004) | H+0.20 (0.008) -0.10 (0.004) | W ₂ ±0.20 (0.008) | A+0.30 (0.012) -0.20 (0.008) | S Min. |
|------|----------|------------|----------------|------------------------------|------------------------------|------------------------------|------------------------------|--------------|
| A | 1206 | 3216-18 | 3.20 (0.126) | 1.60 (0.063) | 1.60 (0.063) | 1.20 (0.047) | 0.80 (0.031) | 1.10 (0.043) |
| B | 1210 | 3528-21 | 3.50 (0.138) | 2.80 (0.110) | 1.90 (0.075) | 2.20 (0.087) | 0.80 (0.031) | 1.40 (0.055) |
| C | 2312 | 6032-28 | 6.00 (0.236) | 3.20 (0.126) | 2.60 (0.102) | 2.20 (0.087) | 1.30 (0.051) | 2.90 (0.114) |
| D | 2917 | 7343-31 | 7.30 (0.287) | 4.30 (0.169) | 2.90 (0.114) | 2.40 (0.094) | 1.30 (0.051) | 4.40 (0.173) |
| E | 2917 | 7343-43 | 7.30 (0.287) | 4.30 (0.169) | 4.10 (0.162) | 2.40 (0.094) | 1.30 (0.051) | 4.40 (0.173) |
| F | 2312 | 6032-20 | 6.00 (0.236) | 3.20 (0.126) | 2.00 (0.079) max. | 2.20 (0.087) | 1.30 (0.051) | 2.90 (0.114) |
| P | 0805 | 2012-15 | 2.05 (0.081) | 1.35 (0.053) | 1.50 (0.059) max. | 1.00±0.10 (0.039±0.004) | 0.50 (0.020) | 0.85 (0.033) |
| R | 0805 | 2012-12 | 2.05 (0.081) | 1.30 (0.051) | 1.20 (0.047) max. | 1.00±0.10 (0.039±0.004) | 0.50 (0.020) | 0.85 (0.033) |
| S | 1206 | 3216-12 | 3.20 (0.126) | 1.60 (0.063) | 1.20 (0.047) max. | 1.20 (0.047) | 0.80 (0.031) | 1.10 (0.043) |
| T | 1210 | 3528-12 | 3.50 (0.138) | 2.80 (0.110) | 1.20 (0.047) max. | 2.20 (0.087) | 0.80 (0.031) | 1.40 (0.055) |
| V | 2924 | 7361-38 | 7.30 (0.287) | 6.10 (0.240) | 3.55 (0.140) | 3.10 (0.120) | 1.30 (0.051) | 4.40 (0.173) |
| W | 2312 | 6032-15 | 6.00 (0.236) | 3.20 (0.126) | 1.50 (0.059) max. | 2.20 (0.087) | 1.30 (0.051) | 2.90 (0.114) |
| X | 2917 | 7343-15 | 7.30 (0.287) | 4.30 (0.169) | 1.50 (0.059) max. | 2.40 (0.094) | 1.30 (0.051) | 4.40 (0.173) |
| Y | 2917 | 7343-20 | 7.30 (0.287) | 4.30 (0.169) | 2.00 (0.079) max. | 2.40 (0.094) | 1.30 (0.051) | 4.40 (0.173) |

W1 dimension applies to the termination width for A dimensional area only.

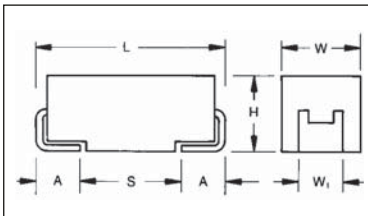

For part marking see page 151

HOW TO ORDER

| | | | | | | | |
|-------------|-------------------------------------|---|--|---|--|------------------|---|
| TPS | C | 107 | M | 010 | R | 0100 | - |
| Type | Case Size See table above | Capacitance Code pF code: 1st two digits represent significant figures, 3rd digit represents multiplier (number of zeros to follow) | Tolerance K = ±10% M = ±20% | Rated DC Voltage 002 = 2.5Vdc 004 = 4Vdc 006 = 6.3Vdc 010 = 10Vdc 016 = 16Vdc 020 = 20Vdc 025 = 25Vdc 035 = 35Vdc 050 = 50Vdc | Packaging R = Pure Tin 7" Reel S = Pure Tin 13" Reel A = Gold Plating 7" Reel B = Gold Plating 13" Reel H = Tin Lead 7" Reel (Contact Manufacturer) K = Tin Lead 13" Reel (Contact Manufacturer) H, K = Non RoHS | ESR in mΩ | Additional characters may be added for special requirements V = Dry pack Option (selected codes only) |

TECHNICAL SPECIFICATIONS

| | | | | | | | | | | |
|------------------------------------|--|-----|-----|-----|----|----|----|----|----|----|
| Technical Data: | All technical data relate to an ambient temperature of +25°C | | | | | | | | | |
| Capacitance Range: | 0.15 µF to 1500 µF | | | | | | | | | |
| Capacitance Tolerance: | ±10%; ±20% | | | | | | | | | |
| Rated Voltage (V _R) | ≤ +85°C: | 2.5 | 4 | 6.3 | 10 | 16 | 20 | 25 | 35 | 50 |
| Category Voltage (V _C) | ≤ +125°C: | 1.7 | 2.7 | 4 | 7 | 10 | 13 | 17 | 23 | 33 |
| Surge Voltage (V _S) | ≤ +85°C: | 3.3 | 5.2 | 8 | 13 | 20 | 26 | 32 | 46 | 65 |
| Surge Voltage (V _S) | ≤ +125°C: | 2.2 | 3.4 | 5 | 8 | 13 | 16 | 20 | 28 | 40 |
| Temperature Range: | -55°C to +125°C | | | | | | | | | |
| Environmental Classification: | 55/125/56 (IEC 68-2) | | | | | | | | | |
| Reliability: | 1% per 1000 hours at 85°C, V _R with 0.1Ω/V series impedance, 60% confidence level | | | | | | | | | |
| Termination Finished: | Sn Plating (standard), Gold and SnPb Plating upon request | | | | | | | | | |
| | For AEC-Q200 availability, please contact AVX | | | | | | | | | |



CAPACITANCE AND RATED VOLTAGE, VR (VOLTAGE CODE) RANGE (LETTER DENOTES CASE SIZE)

| Capacitance | | Rated Voltage DC (V _R) to 85°C | | | | | | | | |
|-------------|------|--|--|---|---|---|--|--|--|----------------------------------|
| µF | Code | 2.5V (e) | 4V (G) | 6.3V (J) | 10V (A) | 16V (C) | 20V (D) | 25V (E) | 35V (V) | 50V (T) |
| 0.15 | 154 | | | | | | | | | A(9000) |
| 0.22 | 224 | | | | | | | | A(6000) | A(7000) |
| 0.33 | 334 | | | | | | | | A(6000) | A(7000) |
| 0.47 | 474 | | | | | | | A(7000) | A(6000) B(4000) | A(6500), B(6000) C(2300) |
| 0.68 | 684 | | | | | | | A(6000) | A(6000) | B(4000) |
| 1.0 | 105 | | | | R(9000) | A(6200) | A(3000), R(6000) S(6000), T(2000) | A(4000) R(2500,4000) | A(3000) B(2000) | B(3000) C(2500) |
| 1.5 | 155 | | | | | | A(3000) | A(3000) B(1800) | A(3000) B(2500) | C(1500,2000) |
| 2.2 | 225 | | | R(7000) | A(1800) | A(1800,3500) T(2000) | A(3000), B(1700) | A(2500) B(900,1200,2500) | A(1500), B(750, 1500,2000), C(1000) | C(1500) D(1200) |
| 3.3 | 335 | | | A(2100) | T(1500) | A(3500), B(2500) | A(2500) B(1300) | A(1000,1500) B(750,1500,2000) | B(1000) C(700) | C(1000) D(800) |
| 4.7 | 475 | | | S(4000) | A(1400), B(1400) R(3000,5000) | A(2000) B(800,1500) | A(1800) B(750,1000) | B(700,900,1500) C(700) | B(700,1500) C(600), D(700) | C(800) D(300,500,700) |
| 6.8 | 685 | | | A(1800) | A(1800), B(1300) T(1800) | A(1500) B(600,1200) | A(1000) B(600,1000) C(700) | B(700) C(500,600,700) | C(350) D(150,400,500) | D(200, 300, 500,600) |
| 10 | 106 | | R(3000) | A(1500), B(1500) R(1000,1500,3000) T(1000) | A(900,1800), B(1000) P(2000) ^M , S(900) T(1000,2000) | A(1000), B(500,800) C(500), T(800,1000) W(500,800) | B(500,1000) C(500,700) W(250, 500) | B(1800) C(300,500) D(500) | C(600) D(125,300) E(200), Y(250) | D(500) E(250,300, 400,500) |
| 15 | 156 | | | A(700,1500) | A(1000) B(450,600), C(700) T(1200) | B(500,800), C(700) | B(500) C(400,450) | C(220,300) D(100,300) | C(350, 450) D(100,300) Y(250) | E(250) V(250) |
| 22 | 226 | | | A(500,900) B(375,600) C(500), S(900) | A(900) B(400,500,700) C(300), T(800) | B(400,600) C(150,250,300,375) D(700), W(500) | B(400,600) C(100,150,400) D(200,300) | C(275,400) D(100,200,300) | D(125,200,300,400) E(125,200,300) Y(200) | |
| 33 | 336 | | | A(600) B(250,350,450,600) T(800) | A(700) B(250,425,500,650) C(150,375,500) W(350) | B(350,500) C(100,150,225,300) D(200), W(140,175, 250,400,500) Y(300,400) | C(300) D(100,200) | D(100,200,300) E(100,175, 200,300) Y(200) | D(200,300) E(100,250,300) V(200) | |
| 47 | 476 | | A(500) | A(800) B(250,350,500) C(300), T(1200) | B(250,350,500,650) C(200,350) D(100,300) W(125,150,250) | C(110,350) D(80,100,150,200) W(200) X(180), Y(250) | D(75,100,200) E(70,125,150, 200,250) X(200) | D(125,150,250) E(80,100,125) Y(250) | E(200,250) V(150,200) | |
| 68 | 686 | | | B(250,350,500) C(150,200) W(110,125,250) | B(600) C(80,100,200,300) D(100,150), W(100,150) Y(100,200) | C(125,200) D(70,100,150) F(200), X(150) Y(150,200,250) | D(70,150, 200,300) E(125,150,200) Y(200) | E(125,200) V(80,95,150,200) | V(150,200) | |
| 100 | 107 | B(200) | B(200,250, 350,500) W(100) | B(250,400) C(75,150), D(300) W(100,150) Y(100) | B(400) ^M C(75,100,150,200) D(50,65,80,100,125, 150), E(125) W(150) X(85,150,200) Y(100,150,200) | C(200) D(60,100,125,150) E(55,100,125,150) F(150,200) ^M Y(100,150,200) | D(85,100,150) E(100,150,200) V(60,85,100,200) | E(150) ^M , V(100) | | |
| 150 | 157 | B(150) | B(250) C(70,80) | C(50,90,150,200,250) D(50,125), Y(40,50) | C(150), D(50,85,100), E(100), F(200), X(100) ^M Y(100,150,200) | D(60,85,100,125,150) E(100), V(45,75) Y(200) ^M | V(80) | V(150) ^M | | |
| 220 | 227 | B(150, 200,600) D(45) | D(40,50,100) Y(40,50,75) | C(70,100,125,250) D(50,100,125) E(100), F(200) Y(100,150) | D(40,50,100,150) E(50,60,70,100, 125,150) Y(100,150,200) | E(100,150) V(50,75,100,150) | | | | |
| 330 | 337 | Y(40) | C(100) D(35,45,100) F(200) X(100) | C(80,100) D(45,50,70,100) E(60,100,125,150) V(100), Y(100,150) | D(60,65,100,150) E(40,60,60,100) V(40,60,100) | E(200) ^M | | | | |
| 470 | 477 | D(35) F(200) Y(100) | D(45,100) E(35,45,100) | D(45,60,100,200) E(45,50,60,100,200) V(40,55,100), Y(150) | E(45,50,60,100,200) V(40,60,100) | | | | | |
| 680 | 687 | D(35,50) E(35,50) Y(100) | D(45,60,100) E(40,60,100) | E(45,60,100) V(35,40,50) | | | | | | |
| 1000 | 108 | E(30,40) Y(100) ^M | E(40,60) V(25,35,40,50) | E(100) ^M , V(40,50) ^M | | | | | | |
| 1500 | 158 | D(100) E(50) V(30,40) ^M | E(50,75) V(50,75) ^M | | | | | | | |

Not recommended for new designs, higher voltage or smaller case size substitution are offered.

Released codes ^(M tolerance only)

Engineering samples - please contact manufacturer

*Codes under development - subject to change

ESR limits quoted in brackets (milliohms)

NOTE: Voltage ratings are minimum values. AVX reserves the right to supply higher ratings in the same case size, to the same reliability standards.

RATINGS & PART NUMBER REFERENCE

| AVX Part No. | Case Size | Capacitance (µF) | Rated Voltage (V) | DCL (µA) Max. | DF % Max. | ESR Max. (mΩ) @100kHz | MSL | 100kHz RMS Current (A) | | | 100kHz RMS Voltage (V) | | |
|---|-----------|------------------|-------------------|---------------|-----------|-----------------------|-----------------|------------------------|-------|-------|------------------------|-------|-------|
| | | | | | | | | 25°C | 85°C | 125°C | 25°C | 85°C | 125°C |
| 2.5 Volt @ 85°C (1.7 Volt @ 125°C) | | | | | | | | | | | | | |
| TPSB107*002#0200 | B | 100 | 2.5 | 2.5 | 8 | 200 | 1 | 0.652 | 0.587 | 0.261 | 0.130 | 0.117 | 0.052 |
| TPSB157*002#0150 | B | 150 | 2.5 | 3 | 10 | 150 | 1 | 0.753 | 0.677 | 0.301 | 0.113 | 0.102 | 0.045 |
| TPSB227*002#0150 | B | 220 | 2.5 | 4.4 | 16 | 150 | 1 | 0.753 | 0.677 | 0.301 | 0.113 | 0.102 | 0.045 |
| TPSB227*002#0200 | B | 220 | 2.5 | 4.4 | 16 | 200 | 1 | 0.652 | 0.587 | 0.261 | 0.130 | 0.117 | 0.052 |
| TPSB227*002#0600 | B | 220 | 2.5 | 4.4 | 16 | 600 | 1 | 0.376 | 0.339 | 0.151 | 0.226 | 0.203 | 0.090 |
| TPSD227*002#0045 | D | 220 | 2.5 | 5.5 | 8 | 45 | 1 | 1.826 | 1.643 | 0.730 | 0.082 | 0.074 | 0.033 |
| TPSY337*002#0040 | Y | 330 | 2.5 | 8.2 | 8 | 40 | 1 ¹⁾ | 1.768 | 1.591 | 0.707 | 0.071 | 0.064 | 0.028 |
| TPSD477*002#0035 | D | 470 | 2.5 | 11.6 | 8 | 35 | 1 | 2.070 | 1.863 | 0.828 | 0.072 | 0.065 | 0.029 |
| TPSF477*002#0200 | F | 470 | 2.5 | 11.8 | 12 | 200 | 1 | 0.707 | 0.636 | 0.283 | 0.141 | 0.127 | 0.057 |
| TPSY477*002#0100 | Y | 470 | 2.5 | 11 | 12 | 100 | 1 ¹⁾ | 1.118 | 1.006 | 0.447 | 0.112 | 0.101 | 0.045 |
| TPSD687*002#0035 | D | 680 | 2.5 | 17 | 16 | 35 | 1 | 2.070 | 1.863 | 0.828 | 0.072 | 0.065 | 0.029 |
| TPSD687*002#0050 | D | 680 | 2.5 | 17 | 16 | 50 | 1 | 1.732 | 1.559 | 0.693 | 0.087 | 0.078 | 0.035 |
| TPSE687*002#0035 | E | 680 | 2.5 | 17 | 10 | 35 | 1 ¹⁾ | 2.171 | 1.954 | 0.868 | 0.076 | 0.068 | 0.030 |
| TPSE687*002#0050 | E | 680 | 2.5 | 17 | 10 | 50 | 1 ¹⁾ | 1.817 | 1.635 | 0.727 | 0.091 | 0.082 | 0.036 |
| TPSY687*002#0100 | Y | 680 | 2.5 | 17 | 12 | 100 | 1 ¹⁾ | 1.118 | 1.006 | 0.447 | 0.112 | 0.101 | 0.045 |
| TPSE108*002#0030 | E | 1000 | 2.5 | 25 | 14 | 30 | 1 ¹⁾ | 2.345 | 2.111 | 0.938 | 0.070 | 0.063 | 0.028 |
| TPSE108*002#0040 | E | 1000 | 2.5 | 25 | 14 | 40 | 1 ¹⁾ | 2.031 | 1.828 | 0.812 | 0.081 | 0.073 | 0.032 |
| TPSY108M002#0100 | Y | 1000 | 2.5 | 25 | 30 | 100 | 1 ¹⁾ | 1.118 | 1.006 | 0.447 | 0.112 | 0.101 | 0.045 |
| TPSD158*002#0100 | D | 1500 | 2.5 | 37.5 | 60 | 100 | 1 | 1.125 | 1.102 | 0.490 | 0.122 | 0.110 | 0.049 |
| TPSE158*002#0050 | E | 1500 | 2.5 | 37.5 | 20 | 50 | 1 ¹⁾ | 1.817 | 1.635 | 0.727 | 0.001 | 0.082 | 0.036 |
| TPSV158M002#0030 | V | 1500 | 2.5 | 30 | 20 | 30 | 1 ¹⁾ | 2.887 | 2.598 | 1.155 | 0.087 | 0.078 | 0.035 |
| TPSV158M002#0040 | V | 1500 | 2.5 | 30 | 20 | 40 | 1 ¹⁾ | 2.500 | 2.250 | 1.000 | 0.100 | 0.090 | 0.040 |
| 4 Volt @ 85°C (2.7 Volt @ 125°C) | | | | | | | | | | | | | |
| TPSR106*004#3000 | R | 10 | 4 | 0.5 | 6 | 3000 | 1 | 0.135 | 0.122 | 0.054 | 0.406 | 0.366 | 0.162 |
| TPSA476*004#0500 | A | 47 | 4 | 1.9 | 8 | 500 | 1 | 0.387 | 0.349 | 0.155 | 0.194 | 0.174 | 0.077 |
| TPSB107*004#0200 | B | 100 | 4 | 4 | 8 | 200 | 1 | 0.652 | 0.587 | 0.261 | 0.130 | 0.117 | 0.052 |
| TPSB107*004#0250 | B | 100 | 4 | 4 | 8 | 250 | 1 | 0.583 | 0.525 | 0.233 | 0.146 | 0.131 | 0.058 |
| TPSB107*004#0350 | B | 100 | 4 | 4 | 8 | 350 | 1 | 0.493 | 0.444 | 0.197 | 0.172 | 0.155 | 0.069 |
| TPSB107*004#0500 | B | 100 | 4 | 4 | 8 | 500 | 1 | 0.412 | 0.371 | 0.165 | 0.206 | 0.186 | 0.082 |
| TPSW107*004#0100 | W | 100 | 4 | 4 | 6 | 100 | 1 | 0.949 | 0.854 | 0.379 | 0.095 | 0.085 | 0.038 |
| TPSB157*004#0250 | B | 150 | 4 | 6 | 10 | 250 | 1 | 0.583 | 0.525 | 0.233 | 0.146 | 0.131 | 0.058 |
| TPSC157*004#0070 | C | 150 | 4 | 6 | 6 | 70 | 1 | 1.254 | 1.128 | 0.501 | 0.088 | 0.079 | 0.035 |
| TPSC157*004#0080 | C | 150 | 4 | 6 | 6 | 80 | 1 | 1.173 | 1.055 | 0.469 | 0.094 | 0.084 | 0.038 |
| TPSD227*004#0040 | D | 220 | 4 | 8.8 | 8 | 40 | 1 | 1.936 | 1.743 | 0.775 | 0.077 | 0.070 | 0.031 |
| TPSD227*004#0050 | D | 220 | 4 | 8.8 | 8 | 50 | 1 | 1.732 | 1.559 | 0.693 | 0.087 | 0.078 | 0.035 |
| TPSD227*004#0100 | D | 220 | 4 | 8.8 | 8 | 100 | 1 | 1.225 | 1.102 | 0.490 | 0.122 | 0.110 | 0.049 |
| TPSY227*004#0040 | Y | 220 | 4 | 8.8 | 8 | 40 | 1 ¹⁾ | 1.768 | 1.591 | 0.707 | 0.071 | 0.064 | 0.028 |
| TPSY227*004#0050 | Y | 220 | 4 | 8.8 | 8 | 50 | 1 ¹⁾ | 1.581 | 1.423 | 0.632 | 0.095 | 0.085 | 0.038 |
| TPSY227*004#0075 | Y | 220 | 4 | 8.8 | 8 | 75 | 1 ¹⁾ | 1.291 | 1.162 | 0.516 | 0.097 | 0.087 | 0.039 |
| TPSC337*004#0100 | C | 330 | 4 | 13.2 | 8 | 100 | 1 | 1.049 | 0.944 | 0.420 | 0.105 | 0.094 | 0.042 |
| TPSD337*004#0035 | D | 330 | 4 | 13.2 | 8 | 35 | 1 | 2.070 | 1.863 | 0.828 | 0.072 | 0.065 | 0.029 |
| TPSD337*004#0045 | D | 330 | 4 | 13.2 | 8 | 45 | 1 | 1.826 | 1.643 | 0.730 | 0.082 | 0.074 | 0.033 |
| TPSD337*004#0100 | D | 330 | 4 | 13.2 | 8 | 100 | 1 | 1.225 | 1.102 | 0.490 | 0.122 | 0.110 | 0.049 |
| TPSF337*004#0200 | F | 330 | 4 | 13.2 | 10 | 200 | 1 | 0.707 | 0.636 | 0.283 | 0.141 | 0.127 | 0.057 |
| TPSX337*004#0100 | X | 330 | 4 | 13.2 | 8 | 100 | 1 ¹⁾ | 1.000 | 0.900 | 0.400 | 0.100 | 0.090 | 0.040 |
| TPSD477*004#0045 | D | 470 | 4 | 18.8 | 12 | 45 | 1 | 1.826 | 1.643 | 0.730 | 0.082 | 0.074 | 0.033 |
| TPSD477*004#0100 | D | 470 | 4 | 18.8 | 12 | 100 | 1 | 1.225 | 1.102 | 0.490 | 0.122 | 0.110 | 0.049 |
| TPSE477*004#0035 | E | 470 | 4 | 18.8 | 10 | 35 | 1 ¹⁾ | 2.171 | 1.954 | 0.868 | 0.076 | 0.068 | 0.030 |
| TPSE477*004#0045 | E | 470 | 4 | 18.8 | 10 | 45 | 1 ¹⁾ | 1.915 | 1.723 | 0.766 | 0.086 | 0.078 | 0.034 |
| TPSE477*004#0100 | E | 470 | 4 | 18.8 | 10 | 100 | 1 ¹⁾ | 1.285 | 1.156 | 0.514 | 0.128 | 0.116 | 0.051 |
| TPSD687*004#0045 | D | 680 | 4 | 27.2 | 14 | 45 | 1 | 1.915 | 1.643 | 0.730 | 0.082 | 0.074 | 0.033 |
| TPSD687*004#0060 | D | 680 | 4 | 27.2 | 14 | 60 | 1 | 1.581 | 1.423 | 0.632 | 0.095 | 0.085 | 0.038 |
| TPSD687*004#0100 | D | 680 | 4 | 27.2 | 14 | 100 | 1 | 1.225 | 1.102 | 0.490 | 0.122 | 0.110 | 0.049 |
| TPSE687*004#0040 | E | 680 | 4 | 27.2 | 10 | 40 | 1 ¹⁾ | 2.031 | 1.828 | 0.812 | 0.081 | 0.073 | 0.032 |
| TPSE687*004#0060 | E | 680 | 4 | 27.2 | 10 | 60 | 1 ¹⁾ | 1.658 | 1.492 | 0.663 | 0.099 | 0.090 | 0.040 |
| TPSE687*004#0100 | E | 680 | 4 | 27.2 | 10 | 100 | 1 ¹⁾ | 1.285 | 1.156 | 0.514 | 0.128 | 0.116 | 0.051 |
| TPSE108*004#0040 | E | 1000 | 4 | 40 | 14 | 40 | 1 ¹⁾ | 2.031 | 1.828 | 0.812 | 0.081 | 0.073 | 0.032 |
| TPSE108*004#0060 | E | 1000 | 4 | 40 | 14 | 60 | 1 ¹⁾ | 1.658 | 1.492 | 0.663 | 0.099 | 0.090 | 0.040 |
| TPSV108*004#0025 | V | 1000 | 4 | 40 | 16 | 25 | 1 ¹⁾ | 3.162 | 2.846 | 1.265 | 0.079 | 0.071 | 0.032 |
| TPSV108*004#0035 | V | 1000 | 4 | 40 | 16 | 35 | 1 ¹⁾ | 2.673 | 2.405 | 1.069 | 0.094 | 0.084 | 0.037 |
| TPSV108*004#0040 | V | 1000 | 4 | 40 | 16 | 40 | 1 ¹⁾ | 2.500 | 2.250 | 1.000 | 0.100 | 0.090 | 0.040 |
| TPSV108*004#0050 | V | 1000 | 4 | 40 | 16 | 50 | 1 ¹⁾ | 2.236 | 2.012 | 0.894 | 0.112 | 0.101 | 0.045 |
| TPSE158*004#0050 | E | 1500 | 4 | 60 | 30 | 50 | 1 ¹⁾ | 1.817 | 1.635 | 0.727 | 0.091 | 0.082 | 0.036 |
| TPSE158*004#0075 | E | 1500 | 4 | 60 | 30 | 75 | 1 ¹⁾ | 1.483 | 1.335 | 0.593 | 0.111 | 0.100 | 0.044 |
| TPSV158M004#0050 | V | 1500 | 4 | 60 | 30 | 50 | 1 ¹⁾ | 2.236 | 2.012 | 0.894 | 0.112 | 0.101 | 0.045 |
| TPSV158M004#0075 | V | 1500 | 4 | 60 | 30 | 75 | 1 ¹⁾ | 1.826 | 1.643 | 0.730 | 0.137 | 0.123 | 0.055 |

¹⁾ Dry pack option (see How to order) recommended for reduction of stress during soldering. Dry pack parts should be treated as MSL 3.

Moisture Sensitivity Level (MSL) is defined according to J-STD-020.

For AEC-Q200 availability, please contact AVX.

All technical data relates to an ambient temperature of +25°C. Capacitance and DF are measured at 120Hz, 0.5V RMS with a maximum DC bias of 2.2 volts. DCL is measured at rated voltage after 5 minutes.

The EIA & CECC standards for low ESR Solid Tantalum Capacitors allow an ESR movement to 1.25 times catalogue limit post mounting.

For typical weight and composition see page 144.

NOTE: AVX reserves the right to supply a higher voltage rating or tighter tolerance part in the same case size, to the same reliability standards.



RATINGS & PART NUMBER REFERENCE

| AVX Part No. | Case Size | Capacitance (µF) | Rated Voltage (V) | DCL (µA) Max. | DF % Max. | ESR Max. (mΩ) @100kHz | MSL | 100kHz RMS Current (A) | | | 100kHz RMS Voltage (V) | | |
|---|-----------|------------------|-------------------|---------------|-----------|-----------------------|-----------------|------------------------|-------|-------|------------------------|-------|-------|
| | | | | | | | | 25°C | 85°C | 125°C | 25°C | 85°C | 125°C |
| 6.3 Volt @ 85°C (4 Volt @ 125°C) | | | | | | | | | | | | | |
| TPSR225*006#7000 | R | 2.2 | 6.3 | 0.5 | 6 | 7000 | 1 | 0.089 | 0.170 | 0.080 | 0.620 | 0.558 | 0.248 |
| TPSA335*006#2100 | A | 3.3 | 6.3 | 0.5 | 6 | 2100 | 1 | 0.189 | 0.170 | 0.076 | 0.397 | 0.357 | 0.159 |
| TPSS475*006#4000 | S | 4.7 | 6.3 | 0.5 | 6 | 4000 | 1 | 0.127 | 0.115 | 0.051 | 0.510 | 0.459 | 0.204 |
| TPSA685*006#1800 | A | 6.8 | 6.3 | 0.5 | 6 | 1800 | 1 | 0.204 | 0.184 | 0.082 | 0.367 | 0.331 | 0.147 |
| TPSA106*006#1500 | A | 10 | 6.3 | 0.6 | 6 | 1500 | 1 | 0.224 | 0.201 | 0.089 | 0.335 | 0.302 | 0.134 |
| TPSB106*006#1500 | B | 10 | 6.3 | 0.6 | 6 | 1500 | 1 | 0.238 | 0.214 | 0.095 | 0.357 | 0.321 | 0.143 |
| TPSR106*006#1000 | R | 10 | 6.3 | 0.6 | 8 | 1000 | 1 | 0.235 | 0.211 | 0.094 | 0.235 | 0.211 | 0.094 |
| TPSR106*006#1500 | R | 10 | 6.3 | 0.6 | 8 | 1500 | 1 | 0.191 | 0.172 | 0.077 | 0.287 | 0.259 | 0.115 |
| TPSR106*006#3000 | R | 10 | 6.3 | 0.6 | 8 | 3000 | 1 | 0.135 | 0.122 | 0.054 | 0.406 | 0.366 | 0.162 |
| TPST106*006#1000 | T | 10 | 6.3 | 0.6 | 6 | 1000 | 1 | 0.283 | 0.255 | 0.113 | 0.283 | 0.255 | 0.113 |
| TPSA156*006#0700 | A | 15 | 6.3 | 0.9 | 6 | 700 | 1 | 0.327 | 0.295 | 0.131 | 0.229 | 0.206 | 0.092 |
| TPSA156*006#1500 | A | 15 | 6.3 | 0.9 | 6 | 1500 | 1 | 0.224 | 0.201 | 0.089 | 0.335 | 0.302 | 0.134 |
| TPSA226*006#0500 | A | 22 | 6.3 | 1.4 | 6 | 500 | 1 | 0.387 | 0.349 | 0.155 | 0.194 | 0.174 | 0.077 |
| TPSA226*006#0900 | A | 22 | 6.3 | 1.4 | 6 | 900 | 1 | 0.289 | 0.260 | 0.115 | 0.260 | 0.234 | 0.104 |
| TPSB226*006#0375 | B | 22 | 6.3 | 1.4 | 6 | 375 | 1 | 0.476 | 0.428 | 0.190 | 0.179 | 0.161 | 0.071 |
| TPSB226*006#0600 | B | 22 | 6.3 | 1.4 | 6 | 600 | 1 | 0.376 | 0.339 | 0.151 | 0.226 | 0.203 | 0.090 |
| TPSC226*006#0500 | C | 22 | 6.3 | 1.4 | 6 | 500 | 1 | 0.469 | 0.422 | 0.188 | 0.235 | 0.211 | 0.094 |
| TPSS226*006#0900 | S | 22 | 6.3 | 1.3 | 10 | 900 | 1 | 0.269 | 0.242 | 0.107 | 0.242 | 0.218 | 0.097 |
| TPSA336*006#0600 | A | 33 | 6.3 | 2.1 | 8 | 600 | 1 | 0.354 | 0.318 | 0.141 | 0.212 | 0.191 | 0.085 |
| TPSB336*006#0250 | B | 33 | 6.3 | 2.1 | 6 | 250 | 1 | 0.583 | 0.525 | 0.233 | 0.146 | 0.131 | 0.058 |
| TPSB336*006#0350 | B | 33 | 6.3 | 2.1 | 6 | 350 | 1 | 0.493 | 0.444 | 0.197 | 0.172 | 0.155 | 0.069 |
| TPSB336*006#0450 | B | 33 | 6.3 | 2.1 | 6 | 450 | 1 | 0.435 | 0.391 | 0.174 | 0.196 | 0.176 | 0.078 |
| TPSB336*006#0600 | B | 33 | 6.3 | 2.1 | 6 | 600 | 1 | 0.376 | 0.339 | 0.151 | 0.226 | 0.203 | 0.090 |
| TPST336*006#0800 | T | 33 | 6.3 | 2.1 | 10 | 800 | 1 | 0.316 | 0.285 | 0.126 | 0.253 | 0.228 | 0.101 |
| TPSA476*006#0800 | A | 47 | 6.3 | 2.8 | 10 | 800 | 1 | 0.306 | 0.276 | 0.122 | 0.245 | 0.220 | 0.098 |
| TPSB476*006#0250 | B | 47 | 6.3 | 3 | 6 | 250 | 1 | 0.583 | 0.525 | 0.233 | 0.146 | 0.131 | 0.058 |
| TPSB476*006#0350 | B | 47 | 6.3 | 3 | 6 | 350 | 1 | 0.493 | 0.444 | 0.197 | 0.172 | 0.155 | 0.069 |
| TPSB476*006#0500 | B | 47 | 6.3 | 3 | 6 | 500 | 1 | 0.412 | 0.371 | 0.165 | 0.206 | 0.186 | 0.082 |
| TPSC476*006#0300 | C | 47 | 6.3 | 3 | 6 | 300 | 1 | 0.606 | 0.545 | 0.242 | 0.182 | 0.163 | 0.073 |
| TPST476*006#1200 | T | 47 | 6.3 | 2.8 | 10 | 1200 | 1 | 0.258 | 0.232 | 0.103 | 0.310 | 0.279 | 0.124 |
| TPSB686*006#0250 | B | 68 | 6.3 | 4 | 8 | 250 | 1 | 0.583 | 0.525 | 0.233 | 0.146 | 0.131 | 0.058 |
| TPSB686*006#0350 | B | 68 | 6.3 | 4 | 8 | 350 | 1 | 0.493 | 0.444 | 0.197 | 0.172 | 0.155 | 0.069 |
| TPSB686*006#0500 | B | 68 | 6.3 | 4 | 8 | 500 | 1 | 0.412 | 0.371 | 0.165 | 0.206 | 0.186 | 0.082 |
| TPSC686*006#0150 | C | 68 | 6.3 | 4.3 | 6 | 150 | 1 | 0.856 | 0.771 | 0.343 | 0.128 | 0.116 | 0.051 |
| TPSC686*006#0200 | C | 68 | 6.3 | 4.3 | 6 | 200 | 1 | 0.742 | 0.667 | 0.297 | 0.148 | 0.133 | 0.059 |
| TPSW686*006#0110 | W | 68 | 6.3 | 4.3 | 6 | 110 | 1 | 0.905 | 0.814 | 0.362 | 0.099 | 0.090 | 0.040 |
| TPSW686*006#0125 | W | 68 | 6.3 | 4.3 | 6 | 125 | 1 | 0.849 | 0.764 | 0.339 | 0.106 | 0.095 | 0.042 |
| TPSW686*006#0250 | W | 68 | 6.3 | 4.3 | 6 | 250 | 1 | 0.600 | 0.540 | 0.240 | 0.150 | 0.135 | 0.060 |
| TPSB107*006#0250 | B | 100 | 6.3 | 6.3 | 10 | 250 | 1 | 0.583 | 0.525 | 0.233 | 0.146 | 0.131 | 0.058 |
| TPSB107*006#0400 | B | 100 | 6.3 | 6.3 | 10 | 400 | 1 | 0.461 | 0.415 | 0.184 | 0.184 | 0.166 | 0.074 |
| TPSC107*006#0075 | C | 100 | 6.3 | 6.3 | 6 | 75 | 1 | 1.211 | 1.090 | 0.484 | 0.091 | 0.082 | 0.036 |
| TPSC107*006#0150 | C | 100 | 6.3 | 6.3 | 6 | 150 | 1 | 0.856 | 0.771 | 0.343 | 0.128 | 0.116 | 0.051 |
| TPSD107*006#0300 | D | 100 | 6.3 | 6.3 | 6 | 300 | 1 | 0.707 | 0.636 | 0.283 | 0.212 | 0.191 | 0.085 |
| TPSW107*006#0100 | W | 100 | 6.3 | 6.3 | 6 | 100 | 1 | 0.949 | 0.854 | 0.379 | 0.095 | 0.085 | 0.038 |
| TPSW107*006#0150 | W | 100 | 6.3 | 6.3 | 6 | 150 | 1 | 0.775 | 0.697 | 0.310 | 0.116 | 0.105 | 0.046 |
| TPSY107*006#0100 | Y | 100 | 6.3 | 6.3 | 6 | 100 | 1 ¹⁾ | 1.118 | 1.006 | 0.447 | 0.112 | 0.101 | 0.045 |
| TPSC157*006#0050 | C | 150 | 6.3 | 9.5 | 6 | 50 | 1 | 1.483 | 1.335 | 0.593 | 0.074 | 0.067 | 0.030 |
| TPSC157*006#0090 | C | 150 | 6.3 | 9.5 | 6 | 90 | 1 | 1.106 | 0.995 | 0.442 | 0.099 | 0.090 | 0.040 |
| TPSC157*006#0150 | C | 150 | 6.3 | 9.5 | 6 | 150 | 1 | 0.856 | 0.771 | 0.343 | 0.128 | 0.116 | 0.051 |
| TPSC157*006#0200 | C | 150 | 6.3 | 9.5 | 6 | 200 | 1 | 0.742 | 0.667 | 0.297 | 0.148 | 0.133 | 0.059 |
| TPSC157*006#0250 | C | 150 | 6.3 | 9.5 | 6 | 250 | 1 | 0.663 | 0.597 | 0.265 | 0.166 | 0.149 | 0.066 |
| TPSD157*006#0050 | D | 150 | 6.3 | 9.5 | 6 | 50 | 1 | 1.732 | 1.559 | 0.693 | 0.087 | 0.078 | 0.035 |
| TPSD157*006#0125 | D | 150 | 6.3 | 9.5 | 6 | 125 | 1 | 1.095 | 0.986 | 0.438 | 0.137 | 0.123 | 0.055 |
| TPSY157*006#0040 | Y | 150 | 6.3 | 9.5 | 6 | 40 | 1 ¹⁾ | 1.768 | 1.591 | 0.707 | 0.071 | 0.064 | 0.028 |
| TPSY157*006#0050 | Y | 150 | 6.3 | 9.5 | 6 | 50 | 1 ¹⁾ | 1.581 | 1.423 | 0.632 | 0.079 | 0.071 | 0.032 |
| TPSC227*006#0070 | C | 220 | 6.3 | 13.9 | 8 | 70 | 1 | 1.254 | 1.128 | 0.501 | 0.088 | 0.079 | 0.035 |
| TPSC227*006#0100 | C | 220 | 6.3 | 13.9 | 8 | 100 | 1 | 1.049 | 0.944 | 0.420 | 0.105 | 0.094 | 0.042 |
| TPSC227*006#0125 | C | 220 | 6.3 | 13.9 | 8 | 125 | 1 | 0.938 | 0.844 | 0.375 | 0.117 | 0.106 | 0.047 |
| TPSC227*006#0250 | C | 220 | 6.3 | 13.9 | 8 | 250 | 1 | 0.663 | 0.597 | 0.265 | 0.166 | 0.149 | 0.066 |
| TPSD227*006#0050 | D | 220 | 6.3 | 13.9 | 8 | 50 | 1 | 1.732 | 1.559 | 0.693 | 0.087 | 0.078 | 0.035 |
| TPSD227*006#0100 | D | 220 | 6.3 | 13.9 | 8 | 100 | 1 | 1.225 | 1.102 | 0.490 | 0.122 | 0.110 | 0.049 |
| TPSD227*006#0125 | D | 220 | 6.3 | 13.9 | 8 | 125 | 1 | 1.095 | 0.986 | 0.438 | 0.137 | 0.123 | 0.055 |
| TPSE227*006#0100 | E | 220 | 6.3 | 13.9 | 8 | 100 | 1 ¹⁾ | 1.285 | 1.156 | 0.514 | 0.128 | 0.116 | 0.051 |
| TPSF227*006#0200 | F | 220 | 6.3 | 13.2 | 10 | 200 | 1 | 0.707 | 0.636 | 0.283 | 0.141 | 0.127 | 0.057 |
| TPSY227*006#0100 | Y | 220 | 6.3 | 13.9 | 8 | 100 | 1 ¹⁾ | 1.118 | 1.006 | 0.447 | 0.112 | 0.101 | 0.045 |
| TPSY227*006#0150 | Y | 220 | 6.3 | 13.9 | 8 | 150 | 1 ¹⁾ | 0.913 | 0.822 | 0.365 | 0.137 | 0.123 | 0.055 |

¹⁾ Dry pack option (see How to order) recommended for reduction of stress during soldering. Dry pack parts should be treated as MSL 3.

Moisture Sensitivity Level (MSL) is defined according to J-STD-020.

For AEC-Q200 availability, please contact AVX.

All technical data relates to an ambient temperature of +25°C. Capacitance and DF are measured at 120Hz, 0.5V RMS with a maximum DC bias of 2.2 volts. DCL is measured at rated voltage after 5 minutes.

The EIA & CECC standards for low ESR Solid Tantalum Capacitors allow an ESR movement to 1.25 times catalogue limit post mounting.

For typical weight and composition see page 144.

NOTE: AVX reserves the right to supply a higher voltage rating or tighter tolerance part in the same case size, to the same reliability standards.

TPS Series



Low ESR

RATINGS & PART NUMBER REFERENCE

| AVX Part No. | Case Size | Capacitance (μF) | Rated Voltage (V) | DCL (μA) Max. | DF % Max. | ESR Max. (mΩ) @100kHz | MSL | 100kHz RMS Current (A) | | | 100kHz RMS Voltage (V) | | |
|--|-----------|------------------|-------------------|---------------|-----------|-----------------------|-----------------|------------------------|-------|-------|------------------------|-------|-------|
| | | | | | | | | 25°C | 85°C | 125°C | 25°C | 85°C | 125°C |
| TPSC337*006#0080 | C | 330 | 6.3 | 19.8 | 12 | 80 | 1 | 1.173 | 1.055 | 0.469 | 0.094 | 0.084 | 0.038 |
| TPSC337*006#0100 | C | 330 | 6.3 | 19.8 | 12 | 100 | 1 | 1.049 | 0.944 | 0.420 | 0.105 | 0.094 | 0.042 |
| TPSD337*006#0045 | D | 330 | 6.3 | 20.8 | 8 | 45 | 1 | 1.826 | 1.643 | 0.730 | 0.082 | 0.074 | 0.033 |
| TPSD337*006#0050 | D | 330 | 6.3 | 20.8 | 8 | 50 | 1 | 1.732 | 1.559 | 0.693 | 0.087 | 0.078 | 0.035 |
| TPSD337*006#0070 | D | 330 | 6.3 | 20.8 | 8 | 70 | 1 | 1.464 | 1.317 | 0.586 | 0.102 | 0.092 | 0.041 |
| TPSD337*006#0100 | D | 330 | 6.3 | 20.8 | 8 | 100 | 1 | 1.225 | 1.102 | 0.490 | 0.122 | 0.110 | 0.049 |
| TPSE337*006#0050 | E | 330 | 6.3 | 20.8 | 8 | 50 | 1 ¹⁾ | 1.817 | 1.635 | 0.727 | 0.091 | 0.082 | 0.036 |
| TPSE337*006#0100 | E | 330 | 6.3 | 20.8 | 8 | 100 | 1 ¹⁾ | 1.285 | 1.156 | 0.514 | 0.128 | 0.116 | 0.051 |
| TPSE337*006#0125 | E | 330 | 6.3 | 20.8 | 8 | 125 | 1 ¹⁾ | 1.149 | 1.034 | 0.460 | 0.144 | 0.129 | 0.057 |
| TPSE337*006#0150 | E | 330 | 6.3 | 20.8 | 8 | 150 | 1 ¹⁾ | 1.049 | 0.944 | 0.420 | 0.157 | 0.142 | 0.063 |
| TPSV337*006#0100 | V | 330 | 6.3 | 20.8 | 8 | 100 | 1 ¹⁾ | 1.581 | 1.423 | 0.632 | 0.158 | 0.142 | 0.063 |
| TPSY337*006#0100 | Y | 330 | 6.3 | 20.8 | 12 | 100 | 1 ¹⁾ | 1.118 | 1.006 | 0.447 | 0.112 | 0.101 | 0.045 |
| TPSY337*006#0150 | Y | 330 | 6.3 | 20.8 | 12 | 150 | 1 ¹⁾ | 0.913 | 0.822 | 0.365 | 0.137 | 0.123 | 0.055 |
| TPSD477*006#0045 | D | 470 | 6.3 | 28 | 12 | 45 | 1 | 1.826 | 1.643 | 0.730 | 0.082 | 0.074 | 0.033 |
| TPSD477*006#0060 | D | 470 | 6.3 | 28 | 12 | 60 | 1 | 1.581 | 1.423 | 0.632 | 0.095 | 0.085 | 0.038 |
| TPSD477*006#0100 | D | 470 | 6.3 | 28 | 12 | 100 | 1 | 1.225 | 1.102 | 0.490 | 0.122 | 0.110 | 0.049 |
| TPSD477*006#0200 | D | 470 | 6.3 | 28 | 12 | 200 | 1 | 0.866 | 0.779 | 0.346 | 0.173 | 0.156 | 0.069 |
| TPSE477*006#0045 | E | 470 | 6.3 | 28 | 10 | 45 | 1 ¹⁾ | 1.915 | 1.723 | 0.766 | 0.086 | 0.078 | 0.034 |
| TPSE477*006#0050 | E | 470 | 6.3 | 28 | 10 | 50 | 1 ¹⁾ | 1.817 | 1.635 | 0.727 | 0.091 | 0.082 | 0.036 |
| TPSE477*006#0060 | E | 470 | 6.3 | 28 | 10 | 60 | 1 ¹⁾ | 1.658 | 1.492 | 0.663 | 0.099 | 0.090 | 0.040 |
| TPSE477*006#0100 | E | 470 | 6.3 | 28 | 10 | 100 | 1 ¹⁾ | 1.285 | 1.156 | 0.514 | 0.128 | 0.116 | 0.051 |
| TPSE477*006#0200 | E | 470 | 6.3 | 28 | 10 | 200 | 1 ¹⁾ | 0.908 | 0.817 | 0.363 | 0.182 | 0.163 | 0.073 |
| TPSV477*006#0040 | V | 470 | 6.3 | 28 | 10 | 40 | 1 ¹⁾ | 2.500 | 2.250 | 1.000 | 0.100 | 0.090 | 0.040 |
| TPSV477*006#0055 | V | 470 | 6.3 | 28 | 10 | 55 | 1 ¹⁾ | 2.132 | 1.919 | 0.853 | 0.117 | 0.106 | 0.047 |
| TPSV477*006#0100 | V | 470 | 6.3 | 28 | 10 | 100 | 1 ¹⁾ | 1.581 | 1.423 | 0.632 | 0.158 | 0.142 | 0.063 |
| TPSY477*006#0150 | Y | 470 | 6.3 | 28.2 | 20 | 150 | 1 ¹⁾ | 0.913 | 0.822 | 0.365 | 0.137 | 0.123 | 0.055 |
| TPSE687*006#0045 | E | 680 | 6.3 | 42.8 | 10 | 45 | 1 ¹⁾ | 1.915 | 1.723 | 0.766 | 0.086 | 0.078 | 0.034 |
| TPSE687*006#0060 | E | 680 | 6.3 | 42.8 | 10 | 60 | 1 ¹⁾ | 1.658 | 1.492 | 0.663 | 0.099 | 0.090 | 0.040 |
| TPSE687*006#0100 | E | 680 | 6.3 | 42.8 | 10 | 100 | 1 ¹⁾ | 1.285 | 1.156 | 0.514 | 0.128 | 0.116 | 0.051 |
| TPSV687*006#0035 | V | 680 | 6.3 | 42.8 | 14 | 35 | 1 ¹⁾ | 2.673 | 2.405 | 1.069 | 0.094 | 0.084 | 0.037 |
| TPSV687*006#0040 | V | 680 | 6.3 | 42.8 | 10 | 40 | 1 ¹⁾ | 2.500 | 2.250 | 1.000 | 0.100 | 0.090 | 0.040 |
| TPSV687*006#0050 | V | 680 | 6.3 | 42.8 | 10 | 50 | 1 ¹⁾ | 2.236 | 2.012 | 0.894 | 0.112 | 0.101 | 0.045 |
| TPSE108M006#0100 | E | 1000 | 6.3 | 60 | 20 | 100 | 1 ¹⁾ | 1.285 | 1.156 | 0.514 | 0.128 | 0.116 | 0.051 |
| TPSV108M006#0040 | V | 1000 | 6.3 | 60 | 16 | 40 | 1 ¹⁾ | 2.500 | 2.250 | 1.000 | 0.100 | 0.090 | 0.040 |
| TPSV108M006#0050 | V | 1000 | 6.3 | 60 | 16 | 50 | 1 ¹⁾ | 2.236 | 2.012 | 0.894 | 0.112 | 0.101 | 0.045 |
| 10 Volt @ 85°C (7 Volt @ 125°C) | | | | | | | | | | | | | |
| TPSR105*010#9000 | R | 1 | 10 | 0.5 | 4 | 9000 | 1 | 0.078 | 0.078 | 0.070 | 0.704 | 0.633 | 0.281 |
| TPSA225*010#1800 | A | 2.2 | 10 | 0.5 | 6 | 1800 | 1 | 0.204 | 0.184 | 0.082 | 0.367 | 0.331 | 0.147 |
| TPST335*010#1500 | T | 3.3 | 10 | 0.5 | 6 | 1500 | 1 | 0.231 | 0.208 | 0.092 | 0.346 | 0.312 | 0.139 |
| TPSA475*010#1400 | A | 4.7 | 10 | 0.5 | 6 | 1400 | 1 | 0.231 | 0.208 | 0.093 | 0.324 | 0.292 | 0.130 |
| TPSB475*010#1400 | B | 4.7 | 10 | 0.5 | 6 | 1400 | 1 | 0.246 | 0.222 | 0.099 | 0.345 | 0.310 | 0.138 |
| TPSR475*010#3000 | R | 4.7 | 10 | 0.5 | 6 | 3000 | 1 | 0.135 | 0.122 | 0.054 | 0.406 | 0.366 | 0.162 |
| TPSR475*010#5000 | R | 4.7 | 10 | 0.5 | 6 | 5000 | 1 | 0.105 | 0.094 | 0.042 | 0.524 | 0.472 | 0.210 |
| TPSA685*010#1800 | A | 6.8 | 10 | 0.7 | 6 | 1800 | 1 | 0.204 | 0.184 | 0.082 | 0.367 | 0.331 | 0.147 |
| TPSB685*010#1300 | B | 6.8 | 10 | 0.7 | 6 | 1300 | 1 | 0.256 | 0.230 | 0.102 | 0.332 | 0.299 | 0.133 |
| TPST685*010#1800 | T | 6.8 | 10 | 0.7 | 6 | 1800 | 1 | 0.211 | 0.190 | 0.084 | 0.379 | 0.342 | 0.152 |
| TPSA106*010#900 | A | 10 | 10 | 1 | 6 | 900 | 1 | 0.289 | 0.260 | 0.115 | 0.260 | 0.234 | 0.104 |
| TPSA106*010#1800 | A | 10 | 10 | 1 | 6 | 1800 | 1 | 0.204 | 0.184 | 0.082 | 0.367 | 0.331 | 0.147 |
| TPSB106*010#1000 | B | 10 | 10 | 1 | 6 | 1000 | 1 | 0.292 | 0.262 | 0.117 | 0.292 | 0.262 | 0.117 |
| TPSP106M010#2000 | P | 10 | 10 | 1 | 8 | 2000 | 1 | 0.173 | 0.156 | 0.069 | 0.346 | 0.312 | 0.139 |
| TPST106*010#900 | S | 10 | 10 | 1 | 8 | 900 | 1 | 0.269 | 0.242 | 0.107 | 0.242 | 0.218 | 0.097 |
| TPST106*010#1000 | T | 10 | 10 | 1 | 6 | 1000 | 1 | 0.283 | 0.255 | 0.113 | 0.283 | 0.255 | 0.113 |
| TPST106*010#2000 | T | 10 | 10 | 1 | 6 | 2000 | 1 | 0.200 | 0.180 | 0.080 | 0.400 | 0.360 | 0.160 |
| TPSA156*010#1000 | A | 15 | 10 | 1.5 | 6 | 1000 | 1 | 0.274 | 0.246 | 0.110 | 0.274 | 0.246 | 0.110 |
| TPSB156*010#0450 | B | 15 | 10 | 1.5 | 6 | 450 | 1 | 0.435 | 0.391 | 0.174 | 0.196 | 0.176 | 0.078 |
| TPSB156*010#0600 | B | 15 | 10 | 1.5 | 6 | 600 | 1 | 0.376 | 0.339 | 0.151 | 0.226 | 0.203 | 0.090 |
| TPSC156*010#0700 | C | 15 | 10 | 1.5 | 6 | 700 | 1 | 0.396 | 0.357 | 0.159 | 0.277 | 0.250 | 0.111 |
| TPST156*010#1200 | T | 15 | 10 | 1.5 | 8 | 1200 | 1 | 0.258 | 0.232 | 0.103 | 0.310 | 0.279 | 0.124 |
| TPSA226*010#0900 | A | 22 | 10 | 2.2 | 8 | 900 | 1 | 0.289 | 0.260 | 0.115 | 0.260 | 0.234 | 0.104 |
| TPSB226*010#0400 | B | 22 | 10 | 2.2 | 6 | 400 | 1 | 0.461 | 0.415 | 0.184 | 0.184 | 0.166 | 0.074 |
| TPSB226*010#0500 | B | 22 | 10 | 2.2 | 6 | 500 | 1 | 0.412 | 0.371 | 0.165 | 0.206 | 0.186 | 0.082 |
| TPSB226*010#0700 | B | 22 | 10 | 2.2 | 6 | 700 | 1 | 0.348 | 0.314 | 0.139 | 0.244 | 0.220 | 0.098 |
| TPSC226*010#0300 | C | 22 | 10 | 2.2 | 6 | 300 | 1 | 0.606 | 0.545 | 0.242 | 0.182 | 0.163 | 0.073 |
| TPST226*010#0800 | T | 22 | 10 | 2.2 | 8 | 800 | 1 | 0.316 | 0.285 | 0.126 | 0.253 | 0.228 | 0.101 |
| TPSA336*010#0700 | A | 33 | 10 | 3.3 | 8 | 700 | 1 | 0.327 | 0.295 | 0.131 | 0.229 | 0.206 | 0.092 |
| TPSB336*010#0250 | B | 33 | 10 | 3.3 | 6 | 250 | 1 | 0.583 | 0.525 | 0.233 | 0.146 | 0.131 | 0.058 |
| TPSB336*010#0425 | B | 33 | 10 | 3.3 | 6 | 425 | 1 | 0.447 | 0.402 | 0.179 | 0.190 | 0.171 | 0.076 |
| TPSB336*010#0500 | B | 33 | 10 | 3.3 | 6 | 500 | 1 | 0.412 | 0.371 | 0.165 | 0.206 | 0.186 | 0.082 |
| TPSB336*010#0650 | B | 33 | 10 | 3.3 | 6 | 650 | 1 | 0.362 | 0.325 | 0.145 | 0.235 | 0.212 | 0.094 |

¹⁾ Dry pack option (see How to order) recommended for reduction of stress during soldering. Dry pack parts should be treated as MSL 3.

Moisture Sensitivity Level (MSL) is defined according to J-STD-020.

For AEC-Q200 availability, please contact AVX.

All technical data relates to an ambient temperature of +25°C. Capacitance and DF are measured at 120Hz, 0.5V RMS with a maximum DC bias of 2.2 volts. DCL is measured at rated voltage after 5 minutes.

The EIA & CECC standards for low ESR Solid Tantalum Capacitors allow an ESR movement to 1.25 times catalogue limit post mounting.

For typical weight and composition see page 144.

NOTE: AVX reserves the right to supply a higher voltage rating or tighter tolerance part in the same case size, to the same reliability standards.



TPS Series



Low ESR

RATINGS & PART NUMBER REFERENCE

| AVX Part No. | Case Size | Capacitance (μF) | Rated Voltage (V) | DCL (μA) Max. | DF % Max. | ESR Max. (mΩ) @100kHz | MSL | 100kHz RMS Current (A) | | | 100kHz RMS Voltage (V) | | |
|------------------|-----------|------------------|-------------------|---------------|-----------|-----------------------|-----------------|------------------------|-------|-------|------------------------|-------|-------|
| | | | | | | | | 25°C | 85°C | 125°C | 25°C | 85°C | 125°C |
| TPSC336*010#0150 | C | 33 | 10 | 3.3 | 6 | 150 | 1 | 0.856 | 0.771 | 0.343 | 0.128 | 0.116 | 0.051 |
| TPSC336*010#0375 | C | 33 | 10 | 3.3 | 6 | 375 | 1 | 0.542 | 0.487 | 0.217 | 0.203 | 0.183 | 0.081 |
| TPSC336*010#0500 | C | 33 | 10 | 3.3 | 6 | 500 | 1 | 0.469 | 0.422 | 0.188 | 0.235 | 0.211 | 0.094 |
| TPSW336*010#0350 | W | 33 | 10 | 3.3 | 6 | 350 | 1 | 0.507 | 0.456 | 0.203 | 0.177 | 0.160 | 0.071 |
| TPSB476*010#0250 | B | 47 | 10 | 4.7 | 8 | 250 | 1 | 0.583 | 0.525 | 0.233 | 0.146 | 0.131 | 0.058 |
| TPSB476*010#0350 | B | 47 | 10 | 4.7 | 8 | 350 | 1 | 0.493 | 0.444 | 0.197 | 0.172 | 0.155 | 0.069 |
| TPSB476*010#0500 | B | 47 | 10 | 4.7 | 8 | 500 | 1 | 0.412 | 0.371 | 0.165 | 0.206 | 0.186 | 0.082 |
| TPSB476*010#0650 | B | 47 | 10 | 4.7 | 8 | 650 | 1 | 0.362 | 0.325 | 0.145 | 0.235 | 0.212 | 0.094 |
| TPSC476*010#0200 | C | 47 | 10 | 4.7 | 6 | 200 | 1 | 0.742 | 0.667 | 0.297 | 0.148 | 0.133 | 0.059 |
| TPSC476*010#0350 | C | 47 | 10 | 4.7 | 6 | 350 | 1 | 0.561 | 0.505 | 0.224 | 0.196 | 0.177 | 0.078 |
| TPSD476*010#0100 | D | 47 | 10 | 4.7 | 6 | 100 | 1 | 1.225 | 1.102 | 0.490 | 0.122 | 0.110 | 0.049 |
| TPSD476*010#0300 | D | 47 | 10 | 4.7 | 6 | 300 | 1 | 0.707 | 0.636 | 0.283 | 0.212 | 0.191 | 0.085 |
| TPSW476*010#0125 | W | 47 | 10 | 4.7 | 6 | 125 | 1 | 0.849 | 0.764 | 0.339 | 0.106 | 0.095 | 0.042 |
| TPSW476*010#0150 | W | 47 | 10 | 4.7 | 6 | 150 | 1 | 0.775 | 0.697 | 0.310 | 0.116 | 0.105 | 0.046 |
| TPSW476*010#0250 | W | 47 | 10 | 4.7 | 6 | 250 | 1 | 0.600 | 0.540 | 0.240 | 0.150 | 0.135 | 0.060 |
| TPSB686*010#0600 | B | 68 | 10 | 6.8 | 8 | 600 | 1 | 0.376 | 0.339 | 0.151 | 0.226 | 0.203 | 0.090 |
| TPSC686*010#0080 | C | 68 | 10 | 6.8 | 6 | 80 | 1 | 1.173 | 1.055 | 0.469 | 0.094 | 0.084 | 0.038 |
| TPSC686*010#0100 | C | 68 | 10 | 6.8 | 6 | 100 | 1 | 1.049 | 0.944 | 0.420 | 0.105 | 0.094 | 0.042 |
| TPSC686*010#0200 | C | 68 | 10 | 6.8 | 6 | 200 | 1 | 0.742 | 0.667 | 0.297 | 0.148 | 0.133 | 0.059 |
| TPSC686*010#0300 | C | 68 | 10 | 6.8 | 6 | 300 | 1 | 0.606 | 0.545 | 0.242 | 0.182 | 0.163 | 0.073 |
| TPSD686*010#0100 | D | 68 | 10 | 6.8 | 6 | 100 | 1 | 1.225 | 1.102 | 0.490 | 0.122 | 0.110 | 0.049 |
| TPSD686*010#0150 | D | 68 | 10 | 6.8 | 6 | 150 | 1 | 1.000 | 0.900 | 0.400 | 0.150 | 0.135 | 0.060 |
| TPSY686*010#0100 | Y | 68 | 10 | 6.8 | 6 | 100 | 1 ¹⁾ | 1.118 | 1.006 | 0.447 | 0.112 | 0.101 | 0.045 |
| TPSY686*010#0200 | Y | 68 | 10 | 6.8 | 6 | 200 | 1 ¹⁾ | 0.791 | 0.712 | 0.316 | 0.158 | 0.142 | 0.063 |
| TPSW686*010#0100 | W | 68 | 10 | 6.8 | 6 | 100 | 1 | 0.949 | 0.854 | 0.379 | 0.095 | 0.085 | 0.038 |
| TPSW686*010#0150 | W | 68 | 10 | 6.8 | 6 | 150 | 1 | 0.775 | 0.697 | 0.310 | 0.116 | 0.105 | 0.046 |
| TPSB107*010#0400 | B | 100 | 10 | 10 | 8 | 400 | 1 | 0.461 | 0.415 | 0.184 | 0.184 | 0.166 | 0.074 |
| TPSC107*010#0075 | C | 100 | 10 | 10 | 8 | 75 | 1 | 1.211 | 1.090 | 0.484 | 0.091 | 0.082 | 0.036 |
| TPSC107*010#0100 | C | 100 | 10 | 10 | 8 | 100 | 1 | 1.049 | 0.944 | 0.420 | 0.105 | 0.094 | 0.042 |
| TPSC107*010#0150 | C | 100 | 10 | 10 | 8 | 150 | 1 | 0.856 | 0.771 | 0.343 | 0.128 | 0.116 | 0.051 |
| TPSC107*010#0200 | C | 100 | 10 | 10 | 8 | 200 | 1 | 0.742 | 0.667 | 0.297 | 0.148 | 0.133 | 0.059 |
| TPSD107*010#0050 | D | 100 | 10 | 10 | 6 | 50 | 1 | 1.732 | 1.559 | 0.693 | 0.087 | 0.078 | 0.035 |
| TPSD107*010#0065 | D | 100 | 10 | 10 | 6 | 65 | 1 | 1.519 | 1.367 | 0.608 | 0.099 | 0.089 | 0.039 |
| TPSD107*010#0080 | D | 100 | 10 | 10 | 6 | 80 | 1 | 1.369 | 1.232 | 0.548 | 0.110 | 0.099 | 0.044 |
| TPSD107*010#0100 | D | 100 | 10 | 10 | 6 | 100 | 1 | 1.225 | 1.102 | 0.490 | 0.122 | 0.110 | 0.049 |
| TPSD107*010#0125 | D | 100 | 10 | 10 | 6 | 125 | 1 | 1.095 | 0.986 | 0.438 | 0.137 | 0.123 | 0.055 |
| TPSD107*010#0150 | D | 100 | 10 | 10 | 6 | 150 | 1 | 1.000 | 0.900 | 0.400 | 0.150 | 0.135 | 0.060 |
| TPSE107*010#0125 | E | 100 | 10 | 10 | 6 | 125 | 1 ¹⁾ | 1.149 | 1.034 | 0.460 | 0.144 | 0.129 | 0.057 |
| TPSW107*010#0150 | W | 100 | 10 | 10 | 6 | 150 | 1 | 0.775 | 0.697 | 0.310 | 0.116 | 0.105 | 0.046 |
| TPSX107*010#0085 | X | 100 | 10 | 10 | 8 | 85 | 1 ¹⁾ | 1.085 | 0.976 | 0.434 | 0.092 | 0.083 | 0.037 |
| TPSX107*010#0150 | X | 100 | 10 | 10 | 8 | 150 | 1 ¹⁾ | 0.816 | 0.735 | 0.327 | 0.122 | 0.110 | 0.049 |
| TPSX107*010#0200 | X | 100 | 10 | 10 | 8 | 200 | 1 ¹⁾ | 0.707 | 0.636 | 0.283 | 0.141 | 0.127 | 0.057 |
| TPSY107*010#0100 | Y | 100 | 10 | 10 | 6 | 100 | 1 ¹⁾ | 1.118 | 1.006 | 0.447 | 0.112 | 0.101 | 0.045 |
| TPSY107*010#0150 | Y | 100 | 10 | 10 | 6 | 150 | 1 ¹⁾ | 0.913 | 0.822 | 0.365 | 0.137 | 0.123 | 0.055 |
| TPSY107*010#0200 | Y | 100 | 10 | 10 | 6 | 200 | 1 ¹⁾ | 0.791 | 0.712 | 0.316 | 0.158 | 0.142 | 0.063 |
| TPSC157*010#0150 | C | 150 | 10 | 15 | 8 | 150 | 1 | 0.856 | 0.771 | 0.343 | 0.128 | 0.116 | 0.051 |
| TPSD157*010#0050 | D | 150 | 10 | 15 | 8 | 50 | 1 | 1.732 | 1.559 | 0.693 | 0.087 | 0.078 | 0.035 |
| TPSD157*010#0085 | D | 150 | 10 | 15 | 8 | 85 | 1 | 1.328 | 1.196 | 0.531 | 0.113 | 0.102 | 0.045 |
| TPSD157*010#0100 | D | 150 | 10 | 15 | 8 | 100 | 1 | 1.225 | 1.102 | 0.490 | 0.122 | 0.110 | 0.049 |
| TPSE157*010#0100 | E | 150 | 10 | 15 | 8 | 100 | 1 ¹⁾ | 1.285 | 1.156 | 0.514 | 0.128 | 0.116 | 0.051 |
| TPSF157*010#0200 | F | 150 | 10 | 15 | 10 | 200 | 1 | 0.707 | 0.636 | 0.283 | 0.141 | 0.127 | 0.057 |
| TPSX157*010#0100 | X | 150 | 10 | 15 | 6 | 100 | 1 ¹⁾ | 1.000 | 0.900 | 0.400 | 0.100 | 0.090 | 0.040 |
| TPSY157*010#0100 | Y | 150 | 10 | 15 | 6 | 100 | 1 ¹⁾ | 1.118 | 1.006 | 0.447 | 0.112 | 0.101 | 0.045 |
| TPSY157*010#0150 | Y | 150 | 10 | 15 | 6 | 150 | 1 ¹⁾ | 0.913 | 0.822 | 0.365 | 0.137 | 0.123 | 0.055 |
| TPSY157*010#0200 | Y | 150 | 10 | 15 | 6 | 200 | 1 ¹⁾ | 0.791 | 0.712 | 0.316 | 0.158 | 0.142 | 0.063 |
| TPSD227*010#0050 | D | 220 | 10 | 22 | 8 | 50 | 1 | 1.732 | 1.559 | 0.693 | 0.087 | 0.078 | 0.035 |
| TPSD227*010#0100 | D | 220 | 10 | 22 | 8 | 100 | 1 | 1.225 | 1.102 | 0.490 | 0.122 | 0.110 | 0.049 |
| TPSD227*010#0150 | D | 220 | 10 | 22 | 8 | 150 | 1 | 1.000 | 0.900 | 0.400 | 0.150 | 0.135 | 0.060 |
| TPSE227*010#0050 | E | 220 | 10 | 22 | 8 | 50 | 1 ¹⁾ | 1.817 | 1.635 | 0.727 | 0.091 | 0.082 | 0.036 |
| TPSE227*010#0060 | E | 220 | 10 | 22 | 8 | 60 | 1 ¹⁾ | 1.658 | 1.492 | 0.663 | 0.099 | 0.090 | 0.040 |
| TPSE227*010#0070 | E | 220 | 10 | 22 | 8 | 70 | 1 ¹⁾ | 1.535 | 1.382 | 0.614 | 0.107 | 0.097 | 0.043 |
| TPSE227*010#0100 | E | 220 | 10 | 22 | 8 | 100 | 1 ¹⁾ | 1.285 | 1.156 | 0.514 | 0.128 | 0.116 | 0.051 |
| TPSE227*010#0125 | E | 220 | 10 | 22 | 8 | 125 | 1 ¹⁾ | 1.149 | 1.034 | 0.460 | 0.144 | 0.129 | 0.057 |
| TPSE227*010#0150 | E | 220 | 10 | 22 | 8 | 150 | 1 ¹⁾ | 1.049 | 0.944 | 0.420 | 0.157 | 0.142 | 0.063 |
| TPSY227*010#0100 | Y | 220 | 10 | 22 | 10 | 100 | 1 ¹⁾ | 1.118 | 1.006 | 0.447 | 0.112 | 0.101 | 0.045 |
| TPSY227*010#0150 | Y | 220 | 10 | 22 | 10 | 150 | 1 ¹⁾ | 0.913 | 0.822 | 0.365 | 0.137 | 0.123 | 0.055 |
| TPSY227*010#0200 | Y | 220 | 10 | 22 | 10 | 200 | 1 ¹⁾ | 0.791 | 0.712 | 0.316 | 0.158 | 0.142 | 0.063 |
| TPSD337*010#0050 | D | 330 | 10 | 33 | 8 | 50 | 1 | 1.732 | 1.559 | 0.693 | 0.087 | 0.078 | 0.035 |

¹⁾ Dry pack option (see How to order) recommended for reduction of stress during soldering. Dry pack parts should be treated as MSL 3.

Moisture Sensitivity Level (MSL) is defined according to J-STD-020.

For AEC-Q200 availability, please contact AVX.

All technical data relates to an ambient temperature of +25°C. Capacitance and DF are measured at 120Hz, 0.5V RMS with a maximum DC bias of 2.2 volts.

DCL is measured at rated voltage after 5 minutes.

The EIA & CECC standards for low ESR Solid Tantalum Capacitors allow an ESR movement to 1.25 times catalogue limit post mounting.

For typical weight and composition see page 144.

NOTE: AVX reserves the right to supply a higher voltage rating or tighter tolerance part in the same case size, to the same reliability standards.



RATINGS & PART NUMBER REFERENCE

| AVX Part No. | Case Size | Capacitance (µF) | Rated Voltage (V) | DCL (µA) Max. | DF % Max. | ESR Max. (mΩ) @100kHz | MSL | 100kHz RMS Current (A) | | | 100kHz RMS Voltage (V) | | |
|---|-----------|------------------|-------------------|---------------|-----------|-----------------------|-----------------|------------------------|-------|-------|------------------------|-------|-------|
| | | | | | | | | 25°C | 85°C | 125°C | 25°C | 85°C | 125°C |
| TPSD337*010#0065 | D | 330 | 10 | 33 | 8 | 65 | 1 | 1.519 | 1.367 | 0.608 | 0.099 | 0.089 | 0.039 |
| TPSD337*010#0100 | D | 330 | 10 | 33 | 8 | 100 | 1 | 1.225 | 1.102 | 0.490 | 0.122 | 0.110 | 0.049 |
| TPSD337*010#0150 | D | 330 | 10 | 33 | 8 | 150 | 1 | 1.000 | 0.900 | 0.400 | 0.150 | 0.135 | 0.060 |
| TPSE337*010#0040 | E | 330 | 10 | 33 | 8 | 40 | 1 ¹⁾ | 2.031 | 1.828 | 0.812 | 0.081 | 0.073 | 0.032 |
| TPSE337*010#0050 | E | 330 | 10 | 33 | 8 | 50 | 1 ¹⁾ | 1.817 | 1.635 | 0.727 | 0.091 | 0.082 | 0.036 |
| TPSE337*010#0060 | E | 330 | 10 | 33 | 8 | 60 | 1 ¹⁾ | 1.658 | 1.492 | 0.663 | 0.099 | 0.090 | 0.040 |
| TPSE337*010#0100 | E | 330 | 10 | 33 | 8 | 100 | 1 ¹⁾ | 1.285 | 1.156 | 0.514 | 0.128 | 0.116 | 0.051 |
| TPSV337*010#0040 | V | 330 | 10 | 33 | 10 | 40 | 1 ¹⁾ | 2.500 | 2.250 | 1.000 | 0.100 | 0.090 | 0.040 |
| TPSV337*010#0060 | V | 330 | 10 | 33 | 10 | 60 | 1 ¹⁾ | 2.041 | 1.837 | 0.816 | 0.122 | 0.110 | 0.049 |
| TPSV337*010#0100 | V | 330 | 10 | 33 | 10 | 100 | 1 ¹⁾ | 1.581 | 1.423 | 0.632 | 0.158 | 0.142 | 0.063 |
| TPSE477*010#0045 | E | 470 | 10 | 47 | 10 | 45 | 1 ¹⁾ | 1.915 | 1.723 | 0.766 | 0.086 | 0.078 | 0.034 |
| TPSE477*010#0050 | E | 470 | 10 | 47 | 10 | 50 | 1 ¹⁾ | 1.817 | 1.635 | 0.727 | 0.091 | 0.082 | 0.036 |
| TPSE477*010#0060 | E | 470 | 10 | 47 | 10 | 60 | 1 ¹⁾ | 1.658 | 1.492 | 0.663 | 0.099 | 0.090 | 0.040 |
| TPSE477*010#0100 | E | 470 | 10 | 47 | 10 | 100 | 1 ¹⁾ | 1.285 | 1.156 | 0.514 | 0.128 | 0.116 | 0.051 |
| TPSE477*010#0200 | E | 470 | 10 | 47 | 10 | 200 | 1 ¹⁾ | 0.908 | 0.817 | 0.363 | 0.182 | 0.163 | 0.073 |
| TPSV477*010#0040 | V | 470 | 10 | 47 | 10 | 40 | 1 ¹⁾ | 2.500 | 2.250 | 1.000 | 0.100 | 0.090 | 0.040 |
| TPSV477*010#0060 | V | 470 | 10 | 47 | 10 | 60 | 1 ¹⁾ | 2.041 | 1.837 | 0.816 | 0.122 | 0.110 | 0.049 |
| TPSV477*010#0100 | V | 470 | 10 | 47 | 10 | 100 | 1 ¹⁾ | 1.581 | 1.423 | 0.632 | 0.158 | 0.142 | 0.063 |
| 16 Volt @ 85°C (10 Volt @ 125°C) | | | | | | | | | | | | | |
| TPSA105*016#6200 | A | 1 | 16 | 0.5 | 4 | 6200 | 1 | 0.110 | 0.099 | 0.044 | 0.682 | 0.614 | 0.273 |
| TPSA225*016#1800 | A | 2.2 | 16 | 0.5 | 6 | 1800 | 1 | 0.204 | 0.184 | 0.082 | 0.367 | 0.331 | 0.147 |
| TPSA225*016#3500 | A | 2.2 | 16 | 0.5 | 6 | 3500 | 1 | 0.146 | 0.132 | 0.059 | 0.512 | 0.461 | 0.205 |
| TPST225*016#2000 | T | 2.2 | 16 | 0.5 | 6 | 2000 | 1 | 0.200 | 0.180 | 0.080 | 0.400 | 0.360 | 0.160 |
| TPSA335*016#3500 | A | 3.3 | 16 | 0.5 | 6 | 3500 | 1 | 0.146 | 0.132 | 0.059 | 0.512 | 0.461 | 0.205 |
| TPSB335*016#2500 | B | 3.3 | 16 | 0.5 | 6 | 2500 | 1 | 0.184 | 0.166 | 0.074 | 0.461 | 0.415 | 0.184 |
| TPSA475*016#2000 | A | 4.7 | 16 | 0.8 | 6 | 2000 | 1 | 0.194 | 0.174 | 0.077 | 0.387 | 0.349 | 0.155 |
| TPSB475*016#0800 | B | 4.7 | 16 | 0.8 | 6 | 800 | 1 | 0.326 | 0.293 | 0.130 | 0.261 | 0.235 | 0.104 |
| TPSB475*016#1500 | B | 4.7 | 16 | 0.8 | 6 | 1500 | 1 | 0.238 | 0.214 | 0.095 | 0.357 | 0.321 | 0.143 |
| TPSA685*016#1500 | A | 6.8 | 16 | 1.1 | 6 | 1500 | 1 | 0.224 | 0.201 | 0.089 | 0.335 | 0.302 | 0.134 |
| TPSB685*016#0600 | B | 6.8 | 16 | 1.1 | 6 | 600 | 1 | 0.376 | 0.339 | 0.151 | 0.226 | 0.203 | 0.090 |
| TPSB685*016#1200 | B | 6.8 | 16 | 1.1 | 6 | 1200 | 1 | 0.266 | 0.240 | 0.106 | 0.319 | 0.287 | 0.128 |
| TPSA106*016#1000 | A | 10 | 16 | 1.6 | 6 | 1000 | 1 | 0.274 | 0.246 | 0.110 | 0.274 | 0.246 | 0.110 |
| TPSB106*016#0500 | B | 10 | 16 | 1.6 | 6 | 500 | 1 | 0.412 | 0.371 | 0.165 | 0.206 | 0.186 | 0.082 |
| TPSB106*016#0800 | B | 10 | 16 | 1.6 | 6 | 800 | 1 | 0.326 | 0.293 | 0.130 | 0.261 | 0.235 | 0.104 |
| TPSC106*016#0500 | C | 10 | 16 | 1.6 | 6 | 500 | 1 | 0.469 | 0.422 | 0.188 | 0.235 | 0.211 | 0.094 |
| TPST106*016#0800 | T | 10 | 16 | 1.6 | 8 | 800 | 1 | 0.316 | 0.285 | 0.126 | 0.253 | 0.228 | 0.101 |
| TPST106*016#1000 | T | 10 | 16 | 1.6 | 8 | 1000 | 1 | 0.283 | 0.255 | 0.113 | 0.283 | 0.255 | 0.113 |
| TPSW106*016#0500 | W | 10 | 16 | 1.6 | 6 | 500 | 1 | 0.424 | 0.382 | 0.170 | 0.212 | 0.191 | 0.085 |
| TPSW106*016#0600 | W | 10 | 16 | 1.6 | 6 | 600 | 1 | 0.387 | 0.349 | 0.155 | 0.232 | 0.209 | 0.093 |
| TPSB156*016#0500 | B | 15 | 16 | 2.4 | 6 | 500 | 1 | 0.412 | 0.371 | 0.165 | 0.206 | 0.186 | 0.082 |
| TPSB156*016#0800 | B | 15 | 16 | 2.4 | 6 | 800 | 1 | 0.326 | 0.293 | 0.130 | 0.261 | 0.235 | 0.104 |
| TPSC156*016#0700 | C | 15 | 16 | 2.4 | 6 | 700 | 1 | 0.396 | 0.357 | 0.159 | 0.277 | 0.250 | 0.111 |
| TPSB226*016#0400 | B | 22 | 16 | 3.5 | 6 | 400 | 1 | 0.461 | 0.415 | 0.184 | 0.184 | 0.166 | 0.074 |
| TPSB226*016#0600 | B | 22 | 16 | 3.5 | 6 | 600 | 1 | 0.376 | 0.339 | 0.151 | 0.226 | 0.203 | 0.090 |
| TPSC226*016#0150 | C | 22 | 16 | 3.5 | 6 | 150 | 1 | 0.856 | 0.771 | 0.343 | 0.128 | 0.116 | 0.051 |
| TPSC226*016#0250 | C | 22 | 16 | 3.5 | 6 | 250 | 1 | 0.663 | 0.597 | 0.265 | 0.166 | 0.149 | 0.066 |
| TPSC226*016#0300 | C | 22 | 16 | 3.5 | 6 | 300 | 1 | 0.606 | 0.545 | 0.242 | 0.182 | 0.163 | 0.073 |
| TPSC226*016#0375 | C | 22 | 16 | 3.5 | 6 | 375 | 1 | 0.542 | 0.487 | 0.217 | 0.203 | 0.183 | 0.081 |
| TPSD226*016#0700 | D | 22 | 16 | 3.5 | 6 | 700 | 1 | 0.463 | 0.417 | 0.185 | 0.324 | 0.292 | 0.130 |
| TPSW226*016#0500 | W | 22 | 16 | 3.5 | 6 | 500 | 1 | 0.424 | 0.382 | 0.170 | 0.212 | 0.191 | 0.085 |
| TPSB336*016#0350 | B | 33 | 16 | 5.3 | 8 | 350 | 1 | 0.493 | 0.444 | 0.197 | 0.172 | 0.155 | 0.069 |
| TPSB336*016#0500 | B | 33 | 16 | 5.3 | 8 | 500 | 1 | 0.412 | 0.371 | 0.165 | 0.206 | 0.186 | 0.082 |
| TPSC336*016#0100 | C | 33 | 16 | 5.3 | 6 | 100 | 1 | 1.049 | 0.944 | 0.420 | 0.105 | 0.094 | 0.042 |
| TPSC336*016#0150 | C | 33 | 16 | 5.3 | 6 | 150 | 1 | 0.856 | 0.771 | 0.343 | 0.128 | 0.116 | 0.051 |
| TPSC336*016#0225 | C | 33 | 16 | 5.3 | 6 | 225 | 1 | 0.699 | 0.629 | 0.280 | 0.157 | 0.142 | 0.063 |
| TPSC336*016#0300 | C | 33 | 16 | 5.3 | 6 | 300 | 1 | 0.606 | 0.545 | 0.242 | 0.182 | 0.163 | 0.073 |
| TPSD336*016#0200 | D | 33 | 16 | 5.3 | 6 | 200 | 1 | 0.866 | 0.779 | 0.346 | 0.173 | 0.156 | 0.069 |
| TPSW336*016#0140 | W | 33 | 16 | 5.3 | 6 | 140 | 1 | 0.802 | 0.722 | 0.321 | 0.112 | 0.101 | 0.045 |
| TPSW336*016#0175 | W | 33 | 16 | 5.3 | 6 | 175 | 1 | 0.717 | 0.645 | 0.287 | 0.125 | 0.113 | 0.050 |
| TPSW336*016#0250 | W | 33 | 16 | 5.3 | 6 | 250 | 1 | 0.600 | 0.540 | 0.240 | 0.150 | 0.135 | 0.060 |
| TPSW336*016#0400 | W | 33 | 16 | 5.3 | 6 | 400 | 1 | 0.474 | 0.427 | 0.190 | 0.190 | 0.171 | 0.076 |
| TPSW336*016#0500 | W | 33 | 16 | 5.3 | 6 | 500 | 1 | 0.424 | 0.382 | 0.170 | 0.212 | 0.191 | 0.085 |
| TPSY336*016#0300 | Y | 33 | 16 | 5.3 | 6 | 300 | 1 ¹⁾ | 0.645 | 0.581 | 0.258 | 0.194 | 0.174 | 0.077 |
| TPSY336*016#0400 | Y | 33 | 16 | 5.3 | 6 | 400 | 1 ¹⁾ | 0.559 | 0.503 | 0.224 | 0.224 | 0.201 | 0.089 |
| TPSC476*016#0110 | C | 47 | 16 | 7.5 | 6 | 110 | 1 | 1.000 | 0.900 | 0.400 | 0.110 | 0.099 | 0.044 |
| TPSC476*016#0350 | C | 47 | 16 | 7.5 | 6 | 350 | 1 | 0.561 | 0.505 | 0.224 | 0.196 | 0.177 | 0.078 |
| TPSD476*016#0080 | D | 47 | 16 | 7.5 | 6 | 80 | 1 | 1.369 | 1.232 | 0.548 | 0.110 | 0.099 | 0.044 |

¹⁾ Dry pack option (see How to order) recommended for reduction of stress during soldering. Dry pack parts should be treated as MSL 3.

Moisture Sensitivity Level (MSL) is defined according to J-STD-020.

For AEC-Q200 availability, please contact AVX.

All technical data relates to an ambient temperature of +25°C. Capacitance and DF are measured at 120Hz, 0.5V RMS with a maximum DC bias of 2.2 volts. DCL is measured at rated voltage after 5 minutes.

The EIA & CECC standards for low ESR Solid Tantalum Capacitors allow an ESR movement to 1.25 times catalogue limit post mounting.

For typical weight and composition see page 144.

NOTE: AVX reserves the right to supply a higher voltage rating or tighter tolerance part in the same case size, to the same reliability standards.

RATINGS & PART NUMBER REFERENCE

| AVX Part No. | Case Size | Capacitance (μF) | Rated Voltage (V) | DCL (μA) Max. | DF % Max. | ESR Max. (mΩ) @100kHz | MSL | 100kHz RMS Current (A) | | | 100kHz RMS Voltage (V) | | |
|----------------------------------|-----------|------------------|-------------------|---------------|-----------|-----------------------|-----------------|------------------------|-------|-------|------------------------|-------|-------|
| | | | | | | | | 25°C | 85°C | 125°C | 25°C | 85°C | 125°C |
| TPSD476*016#0100 | D | 47 | 16 | 7.5 | 6 | 100 | 1 | 1.225 | 1.102 | 0.490 | 0.122 | 0.110 | 0.049 |
| TPSD476*016#0150 | D | 47 | 16 | 7.5 | 6 | 150 | 1 | 1.000 | 0.900 | 0.400 | 0.150 | 0.135 | 0.060 |
| TPSD476*016#0200 | D | 47 | 16 | 7.5 | 6 | 200 | 1 | 0.866 | 0.779 | 0.346 | 0.173 | 0.156 | 0.069 |
| TPSW476*016#0200 | W | 47 | 16 | 7.5 | 6 | 200 | 1 | 0.671 | 0.604 | 0.268 | 0.134 | 0.121 | 0.054 |
| TPSX476*016#0180 | X | 47 | 16 | 7.5 | 6 | 180 | 1 ¹⁾ | 0.745 | 0.671 | 0.298 | 0.134 | 0.121 | 0.054 |
| TPSY476*016#0250 | Y | 47 | 16 | 7.5 | 6 | 250 | 1 ¹⁾ | 0.707 | 0.636 | 0.283 | 0.177 | 0.159 | 0.071 |
| TPSC686*016#0125 | C | 68 | 16 | 10.9 | 6 | 125 | 1 | 0.938 | 0.844 | 0.375 | 0.117 | 0.106 | 0.047 |
| TPSC686*016#0200 | C | 68 | 16 | 10.9 | 6 | 200 | 1 | 0.742 | 0.667 | 0.297 | 0.148 | 0.133 | 0.059 |
| TPSD686*016#0070 | D | 68 | 16 | 10.9 | 6 | 70 | 1 | 1.464 | 1.317 | 0.586 | 0.102 | 0.092 | 0.041 |
| TPSD686*016#0100 | D | 68 | 16 | 10.9 | 6 | 100 | 1 | 1.225 | 1.102 | 0.490 | 0.122 | 0.110 | 0.049 |
| TPSD686*016#0150 | D | 68 | 16 | 10.9 | 6 | 150 | 1 | 1.000 | 0.900 | 0.400 | 0.150 | 0.135 | 0.060 |
| TPSF686*016#0200 | F | 68 | 16 | 10.9 | 10 | 200 | 1 | 0.707 | 0.636 | 0.283 | 0.141 | 0.127 | 0.057 |
| TPSX686*016#0150 | X | 68 | 16 | 10.9 | 8 | 150 | 1 ¹⁾ | 0.816 | 0.735 | 0.327 | 0.122 | 0.110 | 0.049 |
| TPSY686*016#0150 | Y | 68 | 16 | 10.9 | 6 | 150 | 1 ¹⁾ | 0.913 | 0.822 | 0.365 | 0.137 | 0.123 | 0.055 |
| TPSY686*016#0200 | Y | 68 | 16 | 10.9 | 6 | 200 | 1 ¹⁾ | 0.791 | 0.712 | 0.316 | 0.158 | 0.142 | 0.063 |
| TPSY686*016#0250 | Y | 68 | 16 | 10.9 | 6 | 250 | 1 ¹⁾ | 0.707 | 0.636 | 0.283 | 0.177 | 0.159 | 0.071 |
| TPSC107*016#0200 | C | 100 | 16 | 16 | 8 | 200 | 1 | 0.742 | 0.667 | 0.297 | 0.148 | 0.133 | 0.059 |
| TPSD107*016#0060 | D | 100 | 16 | 16 | 6 | 60 | 1 | 1.581 | 1.423 | 0.632 | 0.095 | 0.085 | 0.038 |
| TPSD107*016#0100 | D | 100 | 16 | 16 | 6 | 100 | 1 | 1.225 | 1.102 | 0.490 | 0.122 | 0.110 | 0.049 |
| TPSD107*016#0125 | D | 100 | 16 | 16 | 6 | 125 | 1 | 1.095 | 0.986 | 0.438 | 0.137 | 0.123 | 0.055 |
| TPSD107*016#0150 | D | 100 | 16 | 16 | 6 | 150 | 1 | 1.000 | 0.900 | 0.400 | 0.150 | 0.135 | 0.060 |
| TPSE107*016#0055 | E | 100 | 16 | 16 | 6 | 55 | 1 ¹⁾ | 1.732 | 1.559 | 0.693 | 0.095 | 0.086 | 0.038 |
| TPSE107*016#0100 | E | 100 | 16 | 16 | 6 | 100 | 1 ¹⁾ | 1.285 | 1.156 | 0.514 | 0.128 | 0.116 | 0.051 |
| TPSE107*016#0125 | E | 100 | 16 | 16 | 6 | 125 | 1 ¹⁾ | 1.149 | 1.034 | 0.460 | 0.144 | 0.129 | 0.057 |
| TPSE107*016#0150 | E | 100 | 16 | 16 | 6 | 150 | 1 ¹⁾ | 1.049 | 0.944 | 0.420 | 0.157 | 0.142 | 0.063 |
| TPSF107M016#0150 | F | 100 | 16 | 16 | 10 | 150 | 1 | 0.816 | 0.735 | 0.327 | 0.122 | 0.110 | 0.049 |
| TPSF107M016#0200 | F | 100 | 16 | 16 | 10 | 200 | 1 | 0.707 | 0.636 | 0.283 | 0.141 | 0.127 | 0.057 |
| TPSY107*016#0100 | Y | 100 | 16 | 16 | 8 | 100 | 1 ¹⁾ | 1.118 | 1.006 | 0.447 | 0.112 | 0.101 | 0.045 |
| TPSY107*016#0150 | Y | 100 | 16 | 16 | 8 | 150 | 1 ¹⁾ | 0.913 | 0.822 | 0.365 | 0.137 | 0.123 | 0.055 |
| TPSY107*016#0200 | Y | 100 | 16 | 16 | 8 | 200 | 1 ¹⁾ | 0.791 | 0.712 | 0.316 | 0.158 | 0.142 | 0.063 |
| TPSD157*016#0060 | D | 150 | 16 | 24 | 6 | 60 | 1 | 1.581 | 1.423 | 0.632 | 0.095 | 0.085 | 0.038 |
| TPSD157*016#0085 | D | 150 | 16 | 24 | 6 | 85 | 1 | 1.328 | 1.196 | 0.531 | 0.113 | 0.102 | 0.045 |
| TPSD157*016#0100 | D | 150 | 16 | 24 | 6 | 100 | 1 | 1.225 | 1.102 | 0.490 | 0.122 | 0.110 | 0.049 |
| TPSD157*016#0125 | D | 150 | 16 | 24 | 6 | 125 | 1 | 1.095 | 0.986 | 0.438 | 0.137 | 0.123 | 0.055 |
| TPSD157*016#0150 | D | 150 | 16 | 24 | 6 | 150 | 1 | 1.000 | 0.900 | 0.400 | 0.150 | 0.135 | 0.060 |
| TPSE157*016#0100 | E | 150 | 16 | 23 | 8 | 100 | 1 ¹⁾ | 1.285 | 1.156 | 0.514 | 0.128 | 0.116 | 0.051 |
| TPSV157*016#0045 | V | 150 | 16 | 24 | 8 | 45 | 1 ¹⁾ | 2.357 | 2.121 | 0.943 | 0.106 | 0.095 | 0.042 |
| TPSV157*016#0075 | V | 150 | 16 | 24 | 8 | 75 | 1 ¹⁾ | 1.826 | 1.643 | 0.730 | 0.137 | 0.123 | 0.055 |
| TPSY157M016#0200 | Y | 150 | 16 | 24 | 15 | 200 | 1 ¹⁾ | 0.791 | 0.712 | 0.316 | 0.158 | 0.142 | 0.063 |
| TPSE227*016#0100 | E | 220 | 16 | 35.2 | 10 | 100 | 1 ¹⁾ | 1.285 | 1.156 | 0.514 | 0.128 | 0.116 | 0.051 |
| TPSE227*016#0150 | E | 220 | 16 | 35.2 | 10 | 150 | 1 ¹⁾ | 1.049 | 0.944 | 0.420 | 0.157 | 0.142 | 0.063 |
| TPSV227*016#0050 | V | 220 | 16 | 35.2 | 8 | 50 | 1 ¹⁾ | 2.236 | 2.012 | 0.894 | 0.112 | 0.101 | 0.045 |
| TPSV227*016#0075 | V | 220 | 16 | 35.2 | 8 | 75 | 1 ¹⁾ | 1.826 | 1.643 | 0.730 | 0.137 | 0.123 | 0.055 |
| TPSV227*016#0100 | V | 220 | 16 | 35.2 | 8 | 100 | 1 ¹⁾ | 1.581 | 1.423 | 0.632 | 0.158 | 0.142 | 0.063 |
| TPSV227*016#0150 | V | 220 | 16 | 35.2 | 8 | 150 | 1 ¹⁾ | 1.291 | 1.162 | 0.516 | 0.194 | 0.174 | 0.077 |
| TPSE337M016#0200 | E | 330 | 16 | 52.8 | 30 | 200 | 1 ¹⁾ | 0.908 | 0.817 | 0.363 | 0.182 | 0.163 | 0.073 |
| 20 Volt @ 85°C (13 Volt @ 125°C) | | | | | | | | | | | | | |
| TPSA105*020#3000 | A | 1 | 20 | 0.5 | 4 | 3000 | 1 | 0.158 | 0.142 | 0.063 | 0.474 | 0.427 | 0.190 |
| TPSR105*020#6000 | R | 1 | 20 | 0.5 | 4 | 6000 | 1 | 0.096 | 0.086 | 0.038 | 0.574 | 0.517 | 0.230 |
| TPSS105*020#6000 | S | 1 | 20 | 0.5 | 4 | 6000 | 1 | 0.104 | 0.094 | 0.042 | 0.624 | 0.562 | 0.250 |
| TPST105*020#2000 | T | 1 | 20 | 0.5 | 4 | 2000 | 1 | 0.200 | 0.180 | 0.080 | 0.400 | 0.360 | 0.160 |
| TPSA155*020#3000 | A | 1.5 | 20 | 0.5 | 6 | 3000 | 1 | 0.158 | 0.142 | 0.063 | 0.474 | 0.427 | 0.190 |
| TPSA225*020#3000 | A | 2.2 | 20 | 0.5 | 6 | 3000 | 1 | 0.158 | 0.142 | 0.063 | 0.474 | 0.427 | 0.190 |
| TPSB225*020#1700 | B | 2.2 | 20 | 0.5 | 6 | 1700 | 1 | 0.224 | 0.201 | 0.089 | 0.380 | 0.342 | 0.152 |
| TPSA335*020#2500 | A | 3.3 | 20 | 0.7 | 6 | 2500 | 1 | 0.173 | 0.156 | 0.069 | 0.433 | 0.390 | 0.173 |
| TPSB335*020#1300 | B | 3.3 | 20 | 0.7 | 6 | 1300 | 1 | 0.256 | 0.230 | 0.102 | 0.332 | 0.299 | 0.133 |
| TPSA475*020#1800 | A | 4.7 | 20 | 0.9 | 6 | 1800 | 1 | 0.204 | 0.184 | 0.082 | 0.367 | 0.331 | 0.147 |
| TPSB475*020#0750 | B | 4.7 | 20 | 0.9 | 6 | 750 | 1 | 0.337 | 0.303 | 0.135 | 0.252 | 0.227 | 0.101 |
| TPSB475*020#1000 | B | 4.7 | 20 | 0.9 | 6 | 1000 | 1 | 0.292 | 0.262 | 0.117 | 0.292 | 0.262 | 0.117 |
| TPSA685*020#1000 | A | 6.8 | 20 | 1.4 | 6 | 1000 | 1 | 0.274 | 0.246 | 0.110 | 0.274 | 0.246 | 0.110 |
| TPSB685*020#0600 | B | 6.8 | 20 | 1.4 | 6 | 600 | 1 | 0.376 | 0.339 | 0.151 | 0.226 | 0.203 | 0.090 |
| TPSB685*020#1000 | B | 6.8 | 20 | 1.4 | 6 | 1000 | 1 | 0.292 | 0.262 | 0.117 | 0.292 | 0.262 | 0.117 |
| TPSC685*020#0700 | C | 6.8 | 20 | 1.4 | 6 | 700 | 1 | 0.396 | 0.357 | 0.159 | 0.277 | 0.250 | 0.111 |
| TPSB106*020#0500 | B | 10 | 20 | 2 | 6 | 500 | 1 | 0.412 | 0.371 | 0.165 | 0.206 | 0.186 | 0.082 |
| TPSB106*020#1000 | B | 10 | 20 | 2 | 6 | 1000 | 1 | 0.292 | 0.262 | 0.117 | 0.292 | 0.262 | 0.117 |
| TPSC106*020#0500 | C | 10 | 20 | 2 | 6 | 500 | 1 | 0.469 | 0.422 | 0.188 | 0.235 | 0.211 | 0.094 |
| TPSC106*020#0700 | C | 10 | 20 | 2 | 6 | 700 | 1 | 0.396 | 0.357 | 0.159 | 0.277 | 0.250 | 0.111 |

¹⁾ Dry pack option (see How to order) recommended for reduction of stress during soldering. Dry pack parts should be treated as MSL 3.

Moisture Sensitivity Level (MSL) is defined according to J-STD-020.

For AEC-Q200 availability, please contact AVX.

All technical data relates to an ambient temperature of +25°C. Capacitance and DF are measured at 120Hz, 0.5V RMS with a maximum DC bias of 2.2 volts.

DCL is measured at rated voltage after 5 minutes.

The EIA & CECC standards for low ESR Solid Tantalum Capacitors allow an ESR movement to 1.25 times catalogue limit post mounting.

For typical weight and composition see page 144.

NOTE: AVX reserves the right to supply a higher voltage rating or tighter tolerance part in the same case size, to the same reliability standards.

RATINGS & PART NUMBER REFERENCE

| AVX Part No. | Case Size | Capacitance (μF) | Rated Voltage (V) | DCL (μA) Max. | DF % Max. | ESR Max. (mΩ) @100kHz | MSL | 100kHz RMS Current (A) | | | 100kHz RMS Voltage (V) | | |
|---|-----------|------------------|-------------------|---------------|-----------|-----------------------|-----------------|------------------------|-------|-------|------------------------|-------|-------|
| | | | | | | | | 25°C | 85°C | 125°C | 25°C | 85°C | 125°C |
| TPSW106*020#0250 | W | 10 | 20 | 2 | 6 | 250 | 1 | 0.600 | 0.540 | 0.240 | 0.150 | 0.135 | 0.060 |
| TPSW106*020#0500 | W | 10 | 20 | 2 | 6 | 500 | 1 | 0.424 | 0.382 | 0.170 | 0.212 | 0.191 | 0.850 |
| TPSB156*020#0500 | B | 15 | 20 | 3 | 6 | 500 | 1 | 0.412 | 0.371 | 0.165 | 0.206 | 0.186 | 0.082 |
| TPSC156*020#0400 | C | 15 | 20 | 3 | 6 | 400 | 1 | 0.524 | 0.472 | 0.210 | 0.210 | 0.189 | 0.084 |
| TPSC156*020#0450 | C | 15 | 20 | 3 | 6 | 450 | 1 | 0.494 | 0.445 | 0.198 | 0.222 | 0.200 | 0.089 |
| TPSB226*020#0400 | B | 22 | 20 | 4.4 | 6 | 400 | 1 | 0.461 | 0.415 | 0.184 | 0.184 | 0.166 | 0.074 |
| TPSB226*020#0600 | B | 22 | 20 | 4.4 | 6 | 600 | 1 | 0.376 | 0.339 | 0.151 | 0.226 | 0.203 | 0.090 |
| TPSC226*020#0100 | C | 22 | 20 | 4.4 | 6 | 100 | 1 | 1.049 | 0.944 | 0.420 | 0.105 | 0.094 | 0.042 |
| TPSC226*020#0150 | C | 22 | 20 | 4.4 | 6 | 150 | 1 | 0.856 | 0.771 | 0.343 | 0.128 | 0.116 | 0.051 |
| TPSC226*020#0400 | C | 22 | 20 | 4.4 | 6 | 400 | 1 | 0.524 | 0.472 | 0.210 | 0.210 | 0.189 | 0.084 |
| TPSD226*020#0200 | D | 22 | 20 | 4.4 | 6 | 200 | 1 | 0.866 | 0.779 | 0.346 | 0.173 | 0.156 | 0.069 |
| TPSD226*020#0300 | D | 22 | 20 | 4.4 | 6 | 300 | 1 | 0.707 | 0.636 | 0.283 | 0.212 | 0.191 | 0.085 |
| TPSC336*020#0300 | C | 33 | 20 | 6.6 | 6 | 300 | 1 | 0.606 | 0.545 | 0.242 | 0.182 | 0.163 | 0.073 |
| TPSD336*020#0100 | D | 33 | 20 | 6.6 | 6 | 100 | 1 | 1.225 | 1.102 | 0.490 | 0.122 | 0.110 | 0.049 |
| TPSD336*020#0200 | D | 33 | 20 | 6.6 | 6 | 200 | 1 | 0.866 | 0.779 | 0.346 | 0.173 | 0.155 | 0.069 |
| TPSD476*020#0075 | D | 47 | 20 | 9.4 | 6 | 75 | 1 | 1.414 | 1.273 | 0.566 | 0.106 | 0.095 | 0.042 |
| TPSD476*020#0100 | D | 47 | 20 | 9.4 | 6 | 100 | 1 | 1.225 | 1.102 | 0.490 | 0.122 | 0.110 | 0.049 |
| TPSD476*020#0200 | D | 47 | 20 | 9.4 | 6 | 200 | 1 | 0.866 | 0.779 | 0.346 | 0.173 | 0.156 | 0.069 |
| TPSE476*020#0070 | E | 47 | 20 | 9.4 | 6 | 70 | 1 ¹⁾ | 1.535 | 1.382 | 0.614 | 0.107 | 0.097 | 0.043 |
| TPSE476*020#0125 | E | 47 | 20 | 9.4 | 6 | 125 | 1 ¹⁾ | 1.149 | 1.034 | 0.460 | 0.144 | 0.129 | 0.057 |
| TPSE476*020#0150 | E | 47 | 20 | 9.4 | 6 | 150 | 1 ¹⁾ | 1.049 | 0.944 | 0.420 | 0.157 | 0.142 | 0.063 |
| TPSE476*020#0200 | E | 47 | 20 | 9.4 | 6 | 200 | 1 ¹⁾ | 0.908 | 0.817 | 0.363 | 0.182 | 0.163 | 0.073 |
| TPSE476*020#0250 | E | 47 | 20 | 9.4 | 6 | 250 | 1 ¹⁾ | 0.812 | 0.731 | 0.325 | 0.203 | 0.183 | 0.081 |
| TPSX476*020#0200 | X | 47 | 20 | 9.4 | 6 | 200 | 1 ¹⁾ | 0.707 | 0.636 | 0.283 | 0.141 | 0.127 | 0.057 |
| TPSD686*020#0070 | D | 68 | 20 | 13.6 | 6 | 70 | 1 | 1.464 | 1.317 | 0.586 | 0.102 | 0.092 | 0.041 |
| TPSD686*020#0150 | D | 68 | 20 | 13.6 | 6 | 150 | 1 | 1.000 | 0.900 | 0.400 | 0.150 | 0.135 | 0.060 |
| TPSD686*020#0200 | D | 68 | 20 | 13.6 | 6 | 200 | 1 | 0.866 | 0.779 | 0.346 | 0.173 | 0.156 | 0.069 |
| TPSD686*020#0300 | D | 68 | 20 | 13.6 | 6 | 300 | 1 | 0.707 | 0.636 | 0.283 | 0.212 | 0.191 | 0.085 |
| TPSE686*020#0125 | E | 68 | 20 | 13.6 | 6 | 125 | 1 ¹⁾ | 1.149 | 1.034 | 0.460 | 0.144 | 0.129 | 0.057 |
| TPSE686*020#0150 | E | 68 | 20 | 13.6 | 6 | 150 | 1 ¹⁾ | 1.049 | 0.944 | 0.420 | 0.157 | 0.142 | 0.063 |
| TPSE686*020#0200 | E | 68 | 20 | 13.6 | 6 | 200 | 1 ¹⁾ | 0.908 | 0.817 | 0.363 | 0.182 | 0.163 | 0.073 |
| TPSY686*020#0200 | Y | 68 | 20 | 13.6 | 6 | 200 | 1 ¹⁾ | 0.791 | 0.712 | 0.316 | 0.158 | 0.142 | 0.063 |
| TPSD107*020#0085 | D | 100 | 20 | 20 | 6 | 85 | 1 | 1.328 | 1.196 | 0.531 | 0.113 | 0.102 | 0.045 |
| TPSD107*020#0100 | D | 100 | 20 | 20 | 6 | 100 | 1 | 1.225 | 1.102 | 0.490 | 0.122 | 0.110 | 0.049 |
| TPSD107*020#0150 | D | 100 | 20 | 20 | 6 | 150 | 1 | 1.000 | 0.900 | 0.400 | 0.150 | 0.135 | 0.060 |
| TPSE107*020#0100 | E | 100 | 20 | 20 | 6 | 100 | 1 ¹⁾ | 1.285 | 1.156 | 0.514 | 0.128 | 0.116 | 0.051 |
| TPSE107*020#0150 | E | 100 | 20 | 20 | 6 | 150 | 1 ¹⁾ | 1.049 | 0.944 | 0.420 | 0.157 | 0.142 | 0.063 |
| TPSE107*020#0200 | E | 100 | 20 | 20 | 6 | 200 | 1 ¹⁾ | 0.908 | 0.817 | 0.363 | 0.182 | 0.163 | 0.073 |
| TPSV107*020#0060 | V | 100 | 20 | 20 | 8 | 60 | 1 ¹⁾ | 2.041 | 1.837 | 0.816 | 0.122 | 0.110 | 0.049 |
| TPSV107*020#0085 | V | 100 | 20 | 20 | 8 | 85 | 1 ¹⁾ | 1.715 | 1.543 | 0.686 | 0.146 | 0.131 | 0.058 |
| TPSV107*020#0100 | V | 100 | 20 | 20 | 8 | 100 | 1 ¹⁾ | 1.581 | 1.423 | 0.632 | 0.158 | 0.142 | 0.063 |
| TPSV107*020#0200 | V | 100 | 20 | 20 | 8 | 200 | 1 ¹⁾ | 1.118 | 1.006 | 0.447 | 0.224 | 0.201 | 0.089 |
| TPSV157*020#0080 | V | 150 | 20 | 30 | 8 | 80 | 1 ¹⁾ | 1.768 | 1.591 | 0.707 | 0.141 | 0.127 | 0.057 |
| 25 Volt @ 85°C (17 Volt @ 125°C) | | | | | | | | | | | | | |
| TPSA474*025#7000 | A | 0.47 | 25 | 0.5 | 4 | 7000 | 1 | 0.104 | 0.093 | 0.041 | 0.725 | 0.652 | 0.290 |
| TPSA684*025#6000 | A | 0.68 | 25 | 0.5 | 4 | 6000 | 1 | 0.112 | 0.101 | 0.045 | 0.671 | 0.604 | 0.268 |
| TPSA105*025#4000 | A | 1 | 25 | 0.5 | 4 | 4000 | 1 | 0.137 | 0.123 | 0.055 | 0.548 | 0.493 | 0.219 |
| TPSR105*025#2500 | R | 1 | 25 | 0.5 | 4 | 2500 | 1 | 0.148 | 0.133 | 0.059 | 0.371 | 0.334 | 0.148 |
| TPSR105*025#4000 | R | 1 | 25 | 0.5 | 4 | 4000 | 1 | 0.117 | 0.106 | 0.047 | 0.469 | 0.422 | 0.188 |
| TPSA155*025#3000 | A | 1.5 | 25 | 0.5 | 6 | 3000 | 1 | 0.158 | 0.142 | 0.063 | 0.474 | 0.427 | 0.190 |
| TPSB155*025#1800 | B | 1.5 | 25 | 0.5 | 6 | 1800 | 1 | 0.217 | 0.196 | 0.087 | 0.391 | 0.352 | 0.156 |
| TPSA225*025#2500 | A | 2.2 | 25 | 0.6 | 6 | 2500 | 1 | 0.173 | 0.156 | 0.069 | 0.433 | 0.390 | 0.173 |
| TPSB225*025#0900 | B | 2.2 | 25 | 0.6 | 6 | 900 | 1 | 0.307 | 0.277 | 0.123 | 0.277 | 0.249 | 0.111 |
| TPSB225*025#1200 | B | 2.2 | 25 | 0.6 | 6 | 1200 | 1 | 0.266 | 0.240 | 0.106 | 0.319 | 0.287 | 0.128 |
| TPSB225*025#2500 | B | 2.2 | 25 | 0.6 | 6 | 2500 | 1 | 0.184 | 0.166 | 0.074 | 0.461 | 0.415 | 0.184 |
| TPSA335*025#1000 | A | 3.3 | 25 | 0.8 | 6 | 1000 | 1 | 0.274 | 0.246 | 0.110 | 0.274 | 0.246 | 0.110 |
| TPSA335*025#1500 | A | 3.3 | 25 | 0.8 | 6 | 1500 | 1 | 0.224 | 0.201 | 0.089 | 0.335 | 0.302 | 0.134 |
| TPSB335*025#0750 | B | 3.3 | 25 | 0.8 | 6 | 750 | 1 | 0.337 | 0.303 | 0.135 | 0.252 | 0.227 | 0.101 |
| TPSB335*025#1500 | B | 3.3 | 25 | 0.8 | 6 | 1500 | 1 | 0.238 | 0.214 | 0.095 | 0.357 | 0.321 | 0.143 |
| TPSB335*025#2000 | B | 3.3 | 25 | 0.8 | 6 | 2000 | 1 | 0.206 | 0.186 | 0.082 | 0.412 | 0.371 | 0.165 |
| TPSB475*025#0700 | B | 4.7 | 25 | 1.2 | 6 | 700 | 1 | 0.348 | 0.314 | 0.139 | 0.244 | 0.220 | 0.098 |
| TPSB475*025#0900 | B | 4.7 | 25 | 1.2 | 6 | 900 | 1 | 0.307 | 0.277 | 0.123 | 0.277 | 0.249 | 0.111 |
| TPSB475*025#1500 | B | 4.7 | 25 | 1.2 | 6 | 1500 | 1 | 0.238 | 0.214 | 0.095 | 0.357 | 0.321 | 0.143 |
| TPSC475*025#0700 | C | 4.7 | 25 | 1.2 | 6 | 700 | 1 | 0.396 | 0.357 | 0.159 | 0.277 | 0.250 | 0.111 |
| TPSB685*025#0700 | B | 6.8 | 25 | 1.7 | 6 | 700 | 1 | 0.348 | 0.314 | 0.139 | 0.244 | 0.220 | 0.098 |
| TPSC685*025#0500 | C | 6.8 | 25 | 1.7 | 6 | 500 | 1 | 0.469 | 0.422 | 0.188 | 0.235 | 0.211 | 0.094 |
| TPSC685*025#0600 | C | 6.8 | 25 | 1.7 | 6 | 600 | 1 | 0.428 | 0.385 | 0.171 | 0.257 | 0.231 | 0.103 |

¹⁾ Dry pack option (see How to order) recommended for reduction of stress during soldering. Dry pack parts should be treated as MSL 3.

Moisture Sensitivity Level (MSL) is defined according to J-STD-020.

For AEC-Q200 availability, please contact AVX.

All technical data relates to an ambient temperature of +25°C. Capacitance and DF are measured at 120Hz, 0.5V RMS with a maximum DC bias of 2.2 volts.

DCL is measured at rated voltage after 5 minutes.

The EIA & CECC standards for low ESR Solid Tantalum Capacitors allow an ESR movement to 1.25 times catalogue limit post mounting.

For typical weight and composition see page 144.

NOTE: AVX reserves the right to supply a higher voltage rating or tighter tolerance part in the same case size, to the same reliability standards.

RATINGS & PART NUMBER REFERENCE

| AVX Part No. | Case Size | Capacitance (µF) | Rated Voltage (V) | DCL (µA) Max. | DF % Max. | ESR Max. (mΩ) @100kHz | MSL | 100kHz RMS Current (A) | | | 100kHz RMS Voltage (V) | | |
|---|-----------|------------------|-------------------|---------------|-----------|-----------------------|-----------------|------------------------|-------|-------|------------------------|-------|-------|
| | | | | | | | | 25°C | 85°C | 125°C | 25°C | 85°C | 125°C |
| TPSC685*025#0700 | C | 6.8 | 25 | 1.7 | 6 | 700 | 1 | 0.396 | 0.357 | 0.159 | 0.277 | 0.250 | 0.111 |
| TPSB106*025#1800 | B | 10 | 25 | 2.5 | 6 | 1800 | 1 | 0.217 | 0.196 | 0.087 | 0.391 | 0.352 | 0.156 |
| TPSC106*025#0300 | C | 10 | 25 | 2.5 | 6 | 300 | 1 | 0.606 | 0.545 | 0.242 | 0.182 | 0.163 | 0.073 |
| TPSC106*025#0500 | C | 10 | 25 | 2.5 | 6 | 500 | 1 | 0.469 | 0.422 | 0.188 | 0.235 | 0.211 | 0.094 |
| TPSD106*025#0500 | D | 10 | 25 | 2.5 | 6 | 500 | 1 | 0.548 | 0.493 | 0.219 | 0.274 | 0.246 | 0.110 |
| TPSC156*025#0220 | C | 15 | 25 | 3.8 | 6 | 220 | 1 | 0.707 | 0.636 | 0.283 | 0.156 | 0.140 | 0.062 |
| TPSC156*025#0300 | C | 15 | 25 | 3.8 | 6 | 300 | 1 | 0.606 | 0.545 | 0.242 | 0.182 | 0.163 | 0.073 |
| TPSD156*025#0100 | D | 15 | 25 | 3.8 | 6 | 100 | 1 | 1.225 | 1.102 | 0.490 | 0.122 | 0.110 | 0.049 |
| TPSD156*025#0300 | D | 15 | 25 | 3.8 | 6 | 300 | 1 | 0.707 | 0.636 | 0.283 | 0.212 | 0.191 | 0.085 |
| TPSC226*025#0275 | C | 22 | 25 | 5.5 | 6 | 275 | 1 | 0.632 | 0.569 | 0.253 | 0.174 | 0.157 | 0.070 |
| TPSC226*025#0400 | C | 22 | 25 | 5.5 | 6 | 400 | 1 | 0.524 | 0.472 | 0.210 | 0.210 | 0.189 | 0.084 |
| TPSD226*025#0100 | D | 22 | 25 | 5.5 | 6 | 100 | 1 | 1.225 | 1.102 | 0.490 | 0.122 | 0.110 | 0.049 |
| TPSD226*025#0200 | D | 22 | 25 | 5.5 | 6 | 200 | 1 | 0.866 | 0.779 | 0.346 | 0.173 | 0.156 | 0.069 |
| TPSD226*025#0300 | D | 22 | 25 | 5.5 | 6 | 300 | 1 | 0.707 | 0.636 | 0.283 | 0.212 | 0.191 | 0.085 |
| TPSD336*025#0100 | D | 33 | 25 | 8.3 | 6 | 100 | 1 | 1.225 | 1.102 | 0.490 | 0.122 | 0.110 | 0.049 |
| TPSD336*025#0200 | D | 33 | 25 | 8.3 | 6 | 200 | 1 | 0.866 | 0.779 | 0.346 | 0.173 | 0.156 | 0.069 |
| TPSD336*025#0300 | D | 33 | 25 | 8.3 | 6 | 300 | 1 | 0.707 | 0.636 | 0.283 | 0.212 | 0.191 | 0.085 |
| TPSE336*025#0100 | E | 33 | 25 | 8.3 | 6 | 100 | 1 ¹⁾ | 1.285 | 1.156 | 0.514 | 0.128 | 0.116 | 0.051 |
| TPSE336*025#0175 | E | 33 | 25 | 8.3 | 6 | 175 | 1 ¹⁾ | 0.971 | 0.874 | 0.388 | 0.170 | 0.153 | 0.068 |
| TPSE336*025#0200 | E | 33 | 25 | 8.3 | 6 | 200 | 1 ¹⁾ | 0.908 | 0.817 | 0.363 | 0.182 | 0.163 | 0.073 |
| TPSE336*025#0300 | E | 33 | 25 | 8.3 | 6 | 300 | 1 ¹⁾ | 0.742 | 0.667 | 0.297 | 0.222 | 0.200 | 0.089 |
| TPSY336*025#0200 | Y | 33 | 25 | 8.3 | 6 | 200 | 1 ¹⁾ | 0.791 | 0.712 | 0.316 | 0.158 | 0.142 | 0.063 |
| TPSD476*025#0125 | D | 47 | 25 | 11.8 | 6 | 125 | 1 | 1.095 | 0.986 | 0.438 | 0.137 | 0.123 | 0.055 |
| TPSD476*025#0150 | D | 47 | 25 | 11.8 | 6 | 150 | 1 | 1.000 | 0.900 | 0.400 | 0.150 | 0.135 | 0.060 |
| TPSD476*025#0250 | D | 47 | 25 | 11.8 | 6 | 250 | 1 | 0.775 | 0.697 | 0.310 | 0.194 | 0.174 | 0.077 |
| TPSE476*025#0080 | E | 47 | 25 | 11.8 | 6 | 80 | 1 ¹⁾ | 1.436 | 1.293 | 0.574 | 0.115 | 0.103 | 0.046 |
| TPSE476*025#0100 | E | 47 | 25 | 11.8 | 6 | 100 | 1 ¹⁾ | 1.285 | 1.156 | 0.514 | 0.128 | 0.116 | 0.051 |
| TPSE476*025#0125 | E | 47 | 25 | 11.8 | 6 | 125 | 1 ¹⁾ | 1.149 | 1.034 | 0.460 | 0.144 | 0.129 | 0.057 |
| TPSY476*025#0250 | Y | 47 | 25 | 11.8 | 6 | 250 | 1 ¹⁾ | 0.707 | 0.636 | 0.283 | 0.177 | 0.159 | 0.071 |
| TPSE686*025#0125 | E | 68 | 25 | 17 | 6 | 125 | 1 ¹⁾ | 1.149 | 1.034 | 0.460 | 0.144 | 0.129 | 0.057 |
| TPSE686*025#0200 | E | 68 | 25 | 17 | 6 | 200 | 1 ¹⁾ | 0.908 | 0.817 | 0.363 | 0.182 | 0.163 | 0.073 |
| TPSV686*025#0080 | V | 68 | 25 | 17 | 6 | 80 | 1 ¹⁾ | 1.768 | 1.591 | 0.707 | 0.141 | 0.127 | 0.057 |
| TPSV686*025#0095 | V | 68 | 25 | 17 | 6 | 95 | 1 ¹⁾ | 1.622 | 1.460 | 0.649 | 0.154 | 0.139 | 0.062 |
| TPSV686*025#0150 | V | 68 | 25 | 17 | 6 | 150 | 1 ¹⁾ | 1.291 | 1.162 | 0.516 | 0.194 | 0.174 | 0.077 |
| TPSV686*025#0200 | V | 68 | 25 | 17 | 6 | 200 | 1 ¹⁾ | 1.118 | 1.006 | 0.447 | 0.224 | 0.201 | 0.089 |
| TPSE107M025#0150 | E | 100 | 25 | 25 | 10 | 150 | 1 ¹⁾ | 1.049 | 0.944 | 0.420 | 0.157 | 0.142 | 0.063 |
| TPSV107*025#0100 | V | 100 | 25 | 25 | 8 | 100 | 1 ¹⁾ | 1.581 | 1.423 | 0.632 | 0.158 | 0.142 | 0.063 |
| TPSV157M025#0150 | V | 150 | 25 | 37.5 | 10 | 150 | 1 ¹⁾ | 1.291 | 1.162 | 0.516 | 0.194 | 0.174 | 0.077 |
| 35 Volt @ 85°C (23 Volt @ 125°C) | | | | | | | | | | | | | |
| TPSA224*035#6000 | A | 0.22 | 35 | 0.5 | 4 | 6000 | 1 | 0.112 | 0.101 | 0.045 | 0.671 | 0.604 | 0.268 |
| TPSA334*035#6000 | A | 0.33 | 35 | 0.5 | 4 | 6000 | 1 | 0.112 | 0.101 | 0.045 | 0.671 | 0.604 | 0.268 |
| TPSA474*035#6000 | A | 0.47 | 35 | 0.5 | 4 | 6000 | 1 | 0.112 | 0.101 | 0.045 | 0.671 | 0.604 | 0.268 |
| TPSB474*035#4000 | B | 0.47 | 35 | 0.5 | 4 | 4000 | 1 | 0.146 | 0.131 | 0.058 | 0.583 | 0.525 | 0.233 |
| TPSA684*035#6000 | A | 0.68 | 35 | 0.5 | 4 | 6000 | 1 | 0.112 | 0.101 | 0.045 | 0.671 | 0.604 | 0.268 |
| TPSA105*035#3000 | A | 1 | 35 | 0.5 | 4 | 3000 | 1 | 0.158 | 0.142 | 0.063 | 0.474 | 0.427 | 0.190 |
| TPSB105*035#2000 | B | 1 | 35 | 0.5 | 4 | 2000 | 1 | 0.206 | 0.186 | 0.082 | 0.412 | 0.371 | 0.165 |
| TPSA155*035#3000 | A | 1.5 | 35 | 0.5 | 6 | 3000 | 1 | 0.158 | 0.142 | 0.063 | 0.474 | 0.427 | 0.190 |
| TPSB155*035#2500 | B | 1.5 | 35 | 0.5 | 6 | 2500 | 1 | 0.184 | 0.166 | 0.074 | 0.461 | 0.415 | 0.184 |
| TPSA225*035#1500 | A | 2.2 | 35 | 0.8 | 6 | 1500 | 1 | 0.224 | 0.201 | 0.089 | 0.335 | 0.302 | 0.134 |
| TPSB225*035#0750 | B | 2.2 | 35 | 0.8 | 6 | 750 | 1 | 0.337 | 0.303 | 0.135 | 0.252 | 0.227 | 0.101 |
| TPSB225*035#1500 | B | 2.2 | 35 | 0.8 | 6 | 1500 | 1 | 0.238 | 0.214 | 0.095 | 0.357 | 0.321 | 0.143 |
| TPSB225*035#2000 | B | 2.2 | 35 | 0.8 | 6 | 2000 | 1 | 0.206 | 0.186 | 0.082 | 0.412 | 0.371 | 0.165 |
| TPSC225*035#1000 | C | 2.2 | 35 | 0.8 | 6 | 1000 | 1 | 0.332 | 0.298 | 0.133 | 0.332 | 0.298 | 0.133 |
| TPSB335*035#1000 | B | 3.3 | 35 | 1.2 | 6 | 1000 | 1 | 0.292 | 0.262 | 0.117 | 0.292 | 0.262 | 0.117 |
| TPSC335*035#0700 | C | 3.3 | 35 | 1.2 | 6 | 700 | 1 | 0.396 | 0.357 | 0.159 | 0.277 | 0.250 | 0.111 |
| TPSB475*035#0700 | B | 4.7 | 35 | 1.6 | 6 | 700 | 1 | 0.348 | 0.314 | 0.139 | 0.244 | 0.220 | 0.098 |
| TPSB475*035#1500 | B | 4.7 | 35 | 1.6 | 6 | 1500 | 1 | 0.238 | 0.214 | 0.095 | 0.357 | 0.321 | 0.143 |
| TPSC475*035#0600 | C | 4.7 | 35 | 1.6 | 6 | 600 | 1 | 0.428 | 0.385 | 0.171 | 0.257 | 0.231 | 0.103 |
| TPSD475*035#0700 | D | 4.7 | 35 | 1.6 | 6 | 700 | 1 | 0.463 | 0.417 | 0.185 | 0.324 | 0.292 | 0.130 |
| TPSC685*035#0350 | C | 6.8 | 35 | 2.4 | 6 | 350 | 1 | 0.561 | 0.505 | 0.224 | 0.196 | 0.177 | 0.078 |
| TPSD685*035#0150 | D | 6.8 | 35 | 2.4 | 6 | 150 | 1 | 1.000 | 0.900 | 0.400 | 0.150 | 0.135 | 0.060 |
| TPSD685*035#0400 | D | 6.8 | 35 | 2.4 | 6 | 400 | 1 | 0.612 | 0.551 | 0.245 | 0.245 | 0.220 | 0.098 |
| TPSD685*035#0500 | D | 6.8 | 35 | 2.4 | 6 | 500 | 1 | 0.548 | 0.493 | 0.219 | 0.274 | 0.246 | 0.110 |
| TPSC106*035#0600 | C | 10 | 35 | 3.5 | 6 | 600 | 1 | 0.428 | 0.385 | 0.171 | 0.257 | 0.231 | 0.103 |
| TPSD106*035#0125 | D | 10 | 35 | 3.5 | 6 | 125 | 1 | 1.095 | 0.986 | 0.438 | 0.137 | 0.123 | 0.055 |
| TPSD106*035#0300 | D | 10 | 35 | 3.5 | 6 | 300 | 1 | 0.707 | 0.636 | 0.283 | 0.212 | 0.191 | 0.085 |
| TPSE106*035#0200 | E | 10 | 35 | 3.5 | 6 | 200 | 1 ¹⁾ | 0.908 | 0.817 | 0.363 | 0.182 | 0.163 | 0.073 |

¹⁾ Dry pack option (see How to order) recommended for reduction of stress during soldering. Dry pack parts should be treated as MSL 3.

Moisture Sensitivity Level (MSL) is defined according to J-STD-020.

For AEC-Q200 availability, please contact AVX.

All technical data relates to an ambient temperature of +25°C. Capacitance and DF are measured at 120Hz, 0.5V RMS with a maximum DC bias of 2.2 volts. DCL is measured at rated voltage after 5 minutes.

The EIA & CECC standards for low ESR Solid Tantalum Capacitors allow an ESR movement to 1.25 times catalogue limit post mounting.

For typical weight and composition see page 144.

NOTE: AVX reserves the right to supply a higher voltage rating or tighter tolerance part in the same case size, to the same reliability standards.

RATINGS & PART NUMBER REFERENCE

| AVX Part No. | Case Size | Capacitance (µF) | Rated Voltage (V) | DCL (µA) Max. | DF % Max. | ESR Max. (mΩ) @100kHz | MSL | 100kHz RMS Current (A) | | | 100kHz RMS Voltage (V) | | |
|---|-----------|------------------|-------------------|---------------|-----------|-----------------------|-----------------|------------------------|-------|-------|------------------------|-------|-------|
| | | | | | | | | 25°C | 85°C | 125°C | 25°C | 85°C | 125°C |
| TPSY106*035#0250 | Y | 10 | 35 | 3.5 | 6 | 250 | 1 ¹⁾ | 0.707 | 0.636 | 0.283 | 0.177 | 0.159 | 0.071 |
| TPSC156*035#0350 | C | 15 | 35 | 5.3 | 6 | 350 | 1 | 0.561 | 0.505 | 0.224 | 0.196 | 0.177 | 0.078 |
| TPSC156*035#0450 | C | 15 | 35 | 5.3 | 6 | 450 | 1 | 0.494 | 0.445 | 0.198 | 0.222 | 0.200 | 0.089 |
| TPSD156*035#0100 | D | 15 | 35 | 5.3 | 6 | 100 | 1 | 1.225 | 1.102 | 0.490 | 0.122 | 0.110 | 0.049 |
| TPSD156*035#0300 | D | 15 | 35 | 5.3 | 6 | 300 | 1 | 0.707 | 0.636 | 0.283 | 0.212 | 0.191 | 0.085 |
| TPSY156*035#0250 | Y | 15 | 35 | 5.3 | 6 | 250 | 1 ¹⁾ | 0.707 | 0.636 | 0.283 | 0.177 | 0.159 | 0.071 |
| TPSD226*035#0125 | D | 22 | 35 | 7.7 | 6 | 125 | 1 | 1.095 | 0.986 | 0.438 | 0.137 | 0.123 | 0.055 |
| TPSD226*035#0200 | D | 22 | 35 | 7.7 | 6 | 200 | 1 | 0.866 | 0.779 | 0.346 | 0.173 | 0.156 | 0.069 |
| TPSD226*035#0300 | D | 22 | 35 | 7.7 | 6 | 300 | 1 | 0.707 | 0.636 | 0.283 | 0.212 | 0.191 | 0.085 |
| TPSD226*035#0400 | D | 22 | 35 | 7.7 | 6 | 400 | 1 | 0.612 | 0.551 | 0.245 | 0.245 | 0.220 | 0.098 |
| TPSE226*035#0125 | E | 22 | 35 | 7.7 | 6 | 125 | 1 ¹⁾ | 1.149 | 1.034 | 0.460 | 0.144 | 0.129 | 0.057 |
| TPSE226*035#0200 | E | 22 | 35 | 7.7 | 6 | 200 | 1 ¹⁾ | 0.908 | 0.817 | 0.363 | 0.182 | 0.163 | 0.073 |
| TPSE226*035#0300 | E | 22 | 35 | 7.7 | 6 | 300 | 1 ¹⁾ | 0.742 | 0.667 | 0.297 | 0.222 | 0.200 | 0.089 |
| TPSY226*035#0200 | Y | 22 | 35 | 7.7 | 6 | 200 | 1 ¹⁾ | 0.791 | 0.712 | 0.316 | 0.158 | 0.142 | 0.063 |
| TPSD336*035#0200 | D | 33 | 35 | 11.6 | 6 | 200 | 1 | 0.866 | 0.779 | 0.346 | 0.173 | 0.156 | 0.069 |
| TPSD336*035#0300 | D | 33 | 35 | 11.6 | 6 | 300 | 1 | 0.707 | 0.636 | 0.283 | 0.212 | 0.191 | 0.085 |
| TPSE336*035#0100 | E | 33 | 35 | 11.6 | 6 | 100 | 1 ¹⁾ | 1.285 | 1.156 | 0.514 | 0.128 | 0.116 | 0.051 |
| TPSE336*035#0250 | E | 33 | 35 | 11.6 | 6 | 250 | 1 ¹⁾ | 0.812 | 0.731 | 0.325 | 0.203 | 0.183 | 0.081 |
| TPSE336*035#0300 | E | 33 | 35 | 11.6 | 6 | 300 | 1 ¹⁾ | 0.742 | 0.667 | 0.297 | 0.222 | 0.200 | 0.089 |
| TPSV336*035#0200 | V | 33 | 35 | 11.6 | 6 | 200 | 1 ¹⁾ | 1.118 | 1.006 | 0.447 | 0.224 | 0.201 | 0.089 |
| TPSE476*035#0200 | E | 47 | 35 | 16.5 | 6 | 200 | 1 ¹⁾ | 0.908 | 0.817 | 0.363 | 0.182 | 0.163 | 0.073 |
| TPSE476*035#0250 | E | 47 | 35 | 16.5 | 6 | 250 | 1 ¹⁾ | 0.812 | 0.731 | 0.325 | 0.203 | 0.183 | 0.081 |
| TPSV476*035#0150 | V | 47 | 35 | 16.5 | 6 | 150 | 1 ¹⁾ | 1.291 | 1.162 | 0.516 | 0.194 | 0.174 | 0.077 |
| TPSV476*035#0200 | V | 47 | 35 | 16.5 | 6 | 200 | 1 ¹⁾ | 1.118 | 1.006 | 0.447 | 0.224 | 0.201 | 0.089 |
| TPSV686*035#0150 | V | 68 | 35 | 23.8 | 6 | 150 | 1 ¹⁾ | 1.291 | 1.162 | 0.516 | 0.194 | 0.174 | 0.077 |
| TPSV686*035#0200 | V | 68 | 35 | 23.8 | 6 | 200 | 1 ¹⁾ | 1.118 | 1.006 | 0.447 | 0.224 | 0.201 | 0.089 |
| 50 Volt @ 85°C (33 Volt @ 125°C) | | | | | | | | | | | | | |
| TPSA154*050#9000 | A | 0.15 | 50 | 0.5 | 4 | 9000 | 1 | 0.091 | 0.082 | 0.037 | 0.822 | 0.739 | 0.329 |
| TPSA224*050#7000 | A | 0.22 | 50 | 0.5 | 4 | 7000 | 1 | 0.104 | 0.093 | 0.041 | 0.725 | 0.652 | 0.290 |
| TPSA334*050#7000 | A | 0.33 | 50 | 0.5 | 4 | 7000 | 1 | 0.104 | 0.093 | 0.041 | 0.725 | 0.652 | 0.290 |
| TPSA474*050#6500 | A | 0.47 | 50 | 0.5 | 4 | 6500 | 1 | 0.107 | 0.097 | 0.043 | 0.698 | 0.628 | 0.279 |
| TPSB474*050#6000 | B | 0.47 | 50 | 0.5 | 4 | 6000 | 1 | 0.119 | 0.107 | 0.048 | 0.714 | 0.643 | 0.286 |
| TPSC474*050#2300 | C | 0.47 | 50 | 0.5 | 4 | 2300 | 1 | 0.219 | 0.197 | 0.087 | 0.503 | 0.453 | 0.201 |
| TPSB684*050#4000 | B | 0.68 | 50 | 0.5 | 4 | 4000 | 1 | 0.146 | 0.131 | 0.058 | 0.583 | 0.525 | 0.233 |
| TPSB105*050#3000 | B | 1 | 50 | 0.5 | 4 | 3000 | 1 | 0.168 | 0.151 | 0.067 | 0.505 | 0.454 | 0.202 |
| TPSC105*050#2500 | C | 1 | 50 | 0.5 | 4 | 2500 | 1 | 0.210 | 0.189 | 0.084 | 0.524 | 0.472 | 0.210 |
| TPSC155*050#1500 | C | 1.5 | 50 | 0.8 | 6 | 1500 | 1 | 0.271 | 0.244 | 0.108 | 0.406 | 0.366 | 0.162 |
| TPSC155*050#2000 | C | 1.5 | 50 | 0.8 | 6 | 2000 | 1 | 0.235 | 0.211 | 0.094 | 0.469 | 0.422 | 0.188 |
| TPSC225*050#1500 | C | 2.2 | 50 | 1.1 | 8 | 1500 | 1 | 0.271 | 0.244 | 0.108 | 0.406 | 0.366 | 0.162 |
| TPSD225*050#1200 | D | 2.2 | 50 | 1.1 | 6 | 1200 | 1 | 0.354 | 0.318 | 0.141 | 0.424 | 0.382 | 0.170 |
| TPSC335*050#1000 | C | 3.3 | 50 | 1.6 | 6 | 1000 | 1 | 0.332 | 0.298 | 0.133 | 0.332 | 0.298 | 0.133 |
| TPSD335*050#0800 | D | 3.3 | 50 | 1.7 | 6 | 800 | 1 | 0.433 | 0.390 | 0.173 | 0.346 | 0.312 | 0.139 |
| TPSC475*050#0800 | C | 4.7 | 50 | 2.4 | 6 | 800 | 1 | 0.371 | 0.334 | 0.148 | 0.297 | 0.267 | 0.119 |
| TPSD475*050#0300 | D | 4.7 | 50 | 2.4 | 6 | 300 | 1 | 0.707 | 0.636 | 0.283 | 0.212 | 0.191 | 0.085 |
| TPSD475*050#0500 | D | 4.7 | 50 | 2.4 | 6 | 500 | 1 | 0.548 | 0.493 | 0.219 | 0.274 | 0.246 | 0.110 |
| TPSD475*050#0700 | D | 4.7 | 50 | 2.4 | 6 | 700 | 1 | 0.463 | 0.417 | 0.185 | 0.324 | 0.292 | 0.130 |
| TPSD685*050#0200 | D | 6.8 | 50 | 3.4 | 6 | 200 | 1 | 0.866 | 0.779 | 0.346 | 0.173 | 0.156 | 0.069 |
| TPSD685*050#0300 | D | 6.8 | 50 | 3.4 | 6 | 300 | 1 | 0.707 | 0.636 | 0.283 | 0.212 | 0.191 | 0.085 |
| TPSD685*050#0500 | D | 6.8 | 50 | 3.4 | 6 | 500 | 1 | 0.548 | 0.493 | 0.219 | 0.274 | 0.246 | 0.110 |
| TPSD685*050#0600 | D | 6.8 | 50 | 3.4 | 6 | 600 | 1 | 0.500 | 0.450 | 0.200 | 0.300 | 0.270 | 0.120 |
| TPSD106*050#0500 | D | 10 | 50 | 5 | 6 | 500 | 1 | 0.548 | 0.493 | 0.219 | 0.274 | 0.246 | 0.110 |
| TPSE106*050#0250 | E | 10 | 50 | 5 | 6 | 250 | 1 ¹⁾ | 0.812 | 0.731 | 0.325 | 0.203 | 0.183 | 0.081 |
| TPSE106*050#0300 | E | 10 | 50 | 5 | 6 | 300 | 1 ¹⁾ | 0.742 | 0.667 | 0.297 | 0.222 | 0.200 | 0.089 |
| TPSE106*050#0400 | E | 10 | 50 | 5 | 6 | 400 | 1 ¹⁾ | 0.642 | 0.578 | 0.257 | 0.257 | 0.231 | 0.103 |
| TPSE106*050#0500 | E | 10 | 50 | 5 | 6 | 500 | 1 ¹⁾ | 0.574 | 0.517 | 0.230 | 0.287 | 0.259 | 0.115 |
| TPSE156*050#0250 | E | 15 | 50 | 7.5 | 6 | 250 | 1 ¹⁾ | 0.812 | 0.731 | 0.325 | 0.203 | 0.183 | 0.081 |
| TPSV156*050#0250 | V | 15 | 50 | 7.5 | 6 | 250 | 1 ¹⁾ | 1.000 | 0.900 | 0.400 | 0.250 | 0.225 | 0.100 |

¹⁾ Dry pack option (see How to order) recommended for reduction of stress during soldering. Dry pack parts should be treated as MSL 3.

Moisture Sensitivity Level (MSL) is defined according to J-STD-020.

For AEC-Q200 availability, please contact AVX.

All technical data relates to an ambient temperature of +25°C. Capacitance and DF are measured at 120Hz, 0.5V RMS with a maximum DC bias of 2.2 volts.

DCL is measured at rated voltage after 5 minutes.

The EIA & CECC standards for low ESR Solid Tantalum Capacitors allow an ESR movement to 1.25 times catalogue limit post mounting.

For typical weight and composition see page 144.

NOTE: AVX reserves the right to supply a higher voltage rating or tighter tolerance part in the same case size, to the same reliability standards.

TPS Automotive Range



Low ESR - Automotive Product Range

TPS AUTOMOTIVE RANGE CAPACITANCE AND RATED VOLTAGE, V_R (VOLTAGE CODE) RANGE (LETTER DENOTES CASE SIZE)

| Capacitance | | Rated Voltage DC (V_R) to 85°C | | | | | | |
|---------------|------|---------------------------------------|--|--------------------------------|--------------------------------|---------------------------|-----------------------------|----------------------------|
| μF | Code | 6.3V (J) | 10V (A) | 16V (C) | 20V (D) | 25V (E) | 35V (V) | 50V (T) |
| 0.15 | 154 | | | | | | | |
| 0.22 | 224 | | | | | | | A(7000) |
| 0.33 | 334 | | | | | | A(6000) | A(7000) |
| 0.47 | 474 | | | | | A(7000) | A(6000) | A(6500), B(6000) |
| 0.68 | 684 | | | | | A(6000) | A(6000) | B(4000) |
| 1.0 | 105 | | | A(6200) | A(3000) | A(4000) | A(3000), B(2000) | B(3000), C(2500) |
| 1.5 | 155 | | | | A(3000) | A(3000) | A(3000), B(2500) | C(1500,2000) |
| 2.2 | 225 | | A(1800) | A(1800,3500) | A(3000), B(1700) | A(2500), B(900,1200,2500) | B(750,1500,2000), C(1000) | C(1500), D(1200) |
| 3.3 | 335 | A(2100) | | A(3500), B(2500) | A(2500), B(1300) | B(750,1500,2000) | B(1000), C(700) | C(1000), D(800) |
| 4.7 | 475 | | A(1400), B(1400) | A(2000), B(800,1500) | A(1800), B(750,1000) | B(700,900), C(700) | B(700,1500), C(600), D(700) | C(800), D(500,700) |
| 6.8 | 685 | | A(1800), B(1300) | A(1500), B(600,1200) | B(600,1000), C(700) | B(700), C(500,600,700) | C(350), D(400,500) | D(500,600) |
| 10 | 106 | A(1500), B(1500) | A(900,1800), B(1000) | A(1000), B(500,800), C(500) | B(500,1000), C(500,700) | C(300,500), D(500) | C(600), D(300) | D(500), E(250,300,400,500) |
| 15 | 156 | A(700,1500) | A(1000), B(450,600), C(700) | B(500,800), C(700) | B(500), C(400,450) | C(220,300), D(300) | D(300) | E(250) |
| 22 | 226 | A(500,900), B(375,600), C(500) | A(900), B(400,500,700), C(300) | B(400,600), C(300,375), D(700) | C(400), D(200,300) | C(275,400), D(200,300) | D(200,300,400), E(200,300) | |
| 33 | 336 | A(600), B(250,350,450,600) | B(250,425,500,650), C(375,500) | C(225,300), D(200) | C(300), D(200) | D(200,300) | E(250,300) | |
| 47 | 476 | B(250,350,500), C(300) | B(250,350,500,650), C(200,350), D(300) | C(350), D(200) | D(200) | D(125,150,250), E(125) | | |
| 68 | 686 | B(250,350,500), C(150,200) | C(200,300), D(150) | C(200), D(150) | D(150,200,300), E(125,150,200) | | | |
| 100 | 107 | C(150), D(300) | C(150,200), D(100,125,150) | D(100,125,150), E(100,125,150) | E(100,150,200) | | | |
| 150 | 157 | C(150,200,250), D(125) | D(85,100), E(100) | E(100) | | | | |
| 220 | 227 | D(100,125) | D(100,150), E(70,100,125,150) | | | | | |
| 330 | 337 | D(70,100), E(100,125,150) | E(50,60,100) | | | | | |
| 470 | 477 | D(45,60,100,200), E(45,50,60,100,200) | | | | | | |
| 680 | 687 | E(45,60,100) | | | | | | |

Not recommended for new designs, higher voltage or smaller case size substitution are offered.

Released codes

Engineering samples - please contact manufacturer

Note: Voltage ratings are minimum values. AVX reserves the right to supply higher ratings in the same case size, to the same reliability standards.

HOW TO ORDER

| | | | | | | | |
|------------|------------------------------|--|---|--|--|-------------------|---|
| TPS | C | 107 | M | 010 | T | 0150 | V |
| Type | Case Size See table above | Capacitance Code pF code: 1st two digits represent significant figures, 3rd digit represents multiplier (number of zeros to follow) | Tolerance K = $\pm 10\%$ M = $\pm 20\%$ | Rated DC Voltage 006 = 6.3Vdc 010 = 10Vdc 016 = 16Vdc 020 = 20Vdc 025 = 25Vdc 035 = 35Vdc 050 = 50Vdc | Packaging T = Automotive Lead Free 7" Reel U = Automotive Lead Free 13" Reel | ESR in m Ω | Dry Pack Option (D,E case sizes mandatory) |

TECHNICAL SPECIFICATIONS

Technical Data:

All technical data relate to an ambient temperature of +25°C

| | | | | | | | | | |
|-------------------------------|--|-----|----|----|----|----|----|----|--|
| Capacitance Range: | 0.22 μF to 680 μF | | | | | | | | |
| Capacitance Tolerance: | $\pm 10\%$; $\pm 20\%$ | | | | | | | | |
| Rated Voltage (V_R) | $\leq +85^\circ\text{C}$: | 6.3 | 10 | 16 | 20 | 25 | 35 | 50 | |
| Category Voltage (V_C) | $\leq +125^\circ\text{C}$: | 4 | 7 | 10 | 13 | 17 | 23 | 33 | |
| Surge Voltage (V_S) | $\leq +85^\circ\text{C}$: | 8 | 13 | 20 | 26 | 32 | 46 | 65 | |
| Surge Voltage (V_S) | $\leq +125^\circ\text{C}$: | 5 | 8 | 13 | 16 | 20 | 28 | 40 | |
| Temperature Range: | -55°C to +125°C | | | | | | | | |
| Environmental Classification: | 55/125/56 (IEC 68-2) | | | | | | | | |
| Reliability: | 1% per 1000 hours at 85°C, V_R with 0.1 Ω /V series impedance, 60% confidence level | | | | | | | | |
| Termination Finished: | Sn Plating (standard), Gold and SnPb Plating upon request | | | | | | | | |
| | Meets requirements of AEC-Q200 | | | | | | | | |



TPS Automotive Range



Low ESR - Automotive Product Range

RATINGS & PART NUMBER REFERENCE

| AVX Part No.* | Case Size | Capacitance (µF) | Rated Voltage (V) | DCL (µA) Max. | DF % Max. | ESR Max. (mΩ) @100kHz | MSL | 100kHz RMS Current (A) | | | 100kHz RMS Voltage (V) | | |
|---|-----------|------------------|-------------------|---------------|-----------|-----------------------|-----|------------------------|-------|-------|------------------------|-------|-------|
| | | | | | | | | 25°C | 85°C | 125°C | 25°C | 85°C | 125°C |
| 6.3 Volt @ 85°C (4 Volt @ 125°C) | | | | | | | | | | | | | |
| TPSA335*006T2100 | A | 3.3 | 6.3 | 0.5 | 6 | 2100 | 1 | 0.189 | 0.170 | 0.076 | 0.397 | 0.357 | 0.159 |
| TPSA106*006T1500 | A | 10 | 6.3 | 0.6 | 6 | 1500 | 1 | 0.224 | 0.201 | 0.089 | 0.335 | 0.302 | 0.134 |
| TPSB106*006T1500 | B | 10 | 6.3 | 0.6 | 6 | 1500 | 1 | 0.238 | 0.214 | 0.095 | 0.357 | 0.321 | 0.143 |
| TPSA156*006T0700 | A | 15 | 6.3 | 0.9 | 6 | 700 | 1 | 0.327 | 0.295 | 0.131 | 0.229 | 0.206 | 0.092 |
| TPSA156*006T1500 | A | 15 | 6.3 | 0.9 | 6 | 1500 | 1 | 0.224 | 0.201 | 0.089 | 0.335 | 0.302 | 0.134 |
| TPSA226*006T0500 | A | 22 | 6.3 | 1.4 | 6 | 500 | 1 | 0.387 | 0.349 | 0.155 | 0.194 | 0.174 | 0.077 |
| TPSA226*006T0900 | A | 22 | 6.3 | 1.4 | 6 | 900 | 1 | 0.289 | 0.260 | 0.115 | 0.260 | 0.234 | 0.104 |
| TPSB226*006T0375 | B | 22 | 6.3 | 1.4 | 6 | 375 | 1 | 0.476 | 0.428 | 0.190 | 0.179 | 0.161 | 0.071 |
| TPSB226*006T0600 | B | 22 | 6.3 | 1.4 | 6 | 600 | 1 | 0.376 | 0.339 | 0.151 | 0.226 | 0.203 | 0.090 |
| TPSC226*006T0500 | C | 22 | 6.3 | 1.4 | 6 | 500 | 1 | 0.469 | 0.422 | 0.188 | 0.235 | 0.211 | 0.094 |
| TPSA336*006T0600 | A | 33 | 6.3 | 2.1 | 8 | 600 | 1 | 0.354 | 0.318 | 0.141 | 0.212 | 0.191 | 0.085 |
| TPSB336*006T0250 | B | 33 | 6.3 | 2.1 | 6 | 250 | 1 | 0.583 | 0.525 | 0.233 | 0.146 | 0.131 | 0.058 |
| TPSB336*006T0350 | B | 33 | 6.3 | 2.1 | 6 | 350 | 1 | 0.493 | 0.444 | 0.197 | 0.172 | 0.155 | 0.069 |
| TPSB336*006T0450 | B | 33 | 6.3 | 2.1 | 6 | 450 | 1 | 0.435 | 0.391 | 0.174 | 0.196 | 0.176 | 0.078 |
| TPSB336*006T0600 | B | 33 | 6.3 | 2.1 | 6 | 600 | 1 | 0.376 | 0.339 | 0.151 | 0.226 | 0.203 | 0.090 |
| TPSB476*006T0250 | B | 47 | 6.3 | 3 | 6 | 250 | 1 | 0.583 | 0.525 | 0.233 | 0.146 | 0.131 | 0.058 |
| TPSB476*006T0350 | B | 47 | 6.3 | 3 | 6 | 350 | 1 | 0.493 | 0.444 | 0.197 | 0.172 | 0.155 | 0.069 |
| TPSB476*006T0500 | B | 47 | 6.3 | 3 | 6 | 500 | 1 | 0.412 | 0.371 | 0.165 | 0.206 | 0.186 | 0.082 |
| TPSC476*006T0300 | C | 47 | 6.3 | 3 | 6 | 300 | 1 | 0.606 | 0.545 | 0.242 | 0.182 | 0.163 | 0.073 |
| TPSB686*006T0250 | B | 68 | 6.3 | 4 | 8 | 250 | 1 | 0.583 | 0.525 | 0.233 | 0.146 | 0.131 | 0.058 |
| TPSB686*006T0350 | B | 68 | 6.3 | 4 | 8 | 350 | 1 | 0.493 | 0.444 | 0.197 | 0.172 | 0.155 | 0.069 |
| TPSB686*006T0500 | B | 68 | 6.3 | 4 | 8 | 500 | 1 | 0.412 | 0.371 | 0.165 | 0.206 | 0.186 | 0.082 |
| TPSC686*006T0150 | C | 68 | 6.3 | 4.3 | 6 | 150 | 1 | 0.856 | 0.771 | 0.343 | 0.128 | 0.116 | 0.051 |
| TPSC686*006T0200 | C | 68 | 6.3 | 4.3 | 6 | 200 | 1 | 0.742 | 0.667 | 0.297 | 0.148 | 0.133 | 0.059 |
| TPSC107*006T0150 | C | 100 | 6.3 | 6.3 | 6 | 150 | 1 | 0.856 | 0.771 | 0.343 | 0.128 | 0.116 | 0.051 |
| TPSD107*006T0300V | D | 100 | 6.3 | 6.3 | 6 | 300 | 3 | 0.707 | 0.636 | 0.283 | 0.212 | 0.191 | 0.085 |
| TPSC157*006T0150 | C | 150 | 6.3 | 9.5 | 6 | 150 | 1 | 0.856 | 0.771 | 0.343 | 0.128 | 0.116 | 0.051 |
| TPSC157*006T0200 | C | 150 | 6.3 | 9.5 | 6 | 200 | 1 | 0.742 | 0.667 | 0.297 | 0.148 | 0.133 | 0.059 |
| TPSC157*006T0250 | C | 150 | 6.3 | 9.5 | 6 | 250 | 1 | 0.663 | 0.597 | 0.265 | 0.166 | 0.149 | 0.066 |
| TPSD157*006T0125V | D | 150 | 6.3 | 9.5 | 6 | 125 | 3 | 1.095 | 0.986 | 0.438 | 0.137 | 0.123 | 0.055 |
| TPSD227*006T0100V | D | 220 | 6.3 | 13.9 | 8 | 100 | 3 | 1.225 | 1.102 | 0.490 | 0.122 | 0.110 | 0.049 |
| TPSD227*006T0125V | D | 220 | 6.3 | 13.9 | 8 | 125 | 3 | 1.095 | 0.986 | 0.438 | 0.137 | 0.123 | 0.055 |
| TPSD337*006T0070V | D | 330 | 6.3 | 20.8 | 8 | 70 | 3 | 1.464 | 1.317 | 0.586 | 0.102 | 0.092 | 0.041 |
| TPSD337*006T0100V | D | 330 | 6.3 | 20.8 | 8 | 100 | 3 | 1.225 | 1.102 | 0.490 | 0.122 | 0.110 | 0.049 |
| TPSE337*006T0100V | E | 330 | 6.3 | 20.8 | 8 | 100 | 3 | 1.285 | 1.156 | 0.514 | 0.128 | 0.116 | 0.051 |
| TPSE337*006T0125V | E | 330 | 6.3 | 20.8 | 8 | 125 | 3 | 1.149 | 1.034 | 0.460 | 0.144 | 0.129 | 0.057 |
| TPSE337*006T0150V | E | 330 | 6.3 | 20.8 | 8 | 150 | 3 | 1.049 | 0.944 | 0.420 | 0.157 | 0.142 | 0.063 |
| TPSD477*006T0045V | D | 470 | 6.3 | 28 | 12 | 45 | 3 | 1.826 | 1.643 | 0.730 | 0.082 | 0.074 | 0.033 |
| TPSD477*006T0060V | D | 470 | 6.3 | 28 | 12 | 60 | 3 | 1.581 | 1.423 | 0.632 | 0.095 | 0.085 | 0.038 |
| TPSD477*006T0100V | D | 470 | 6.3 | 28 | 12 | 100 | 3 | 1.225 | 1.102 | 0.490 | 0.122 | 0.110 | 0.049 |
| TPSD477*006T0200V | D | 470 | 6.3 | 28 | 12 | 200 | 3 | 0.866 | 0.779 | 0.346 | 0.173 | 0.156 | 0.069 |
| TPSE477*006T0045V | E | 470 | 6.3 | 28 | 10 | 45 | 3 | 1.915 | 1.723 | 0.766 | 0.086 | 0.078 | 0.034 |
| TPSE477*006T0050V | E | 470 | 6.3 | 28 | 10 | 50 | 3 | 1.817 | 1.635 | 0.727 | 0.091 | 0.082 | 0.036 |
| TPSE477*006T0060V | E | 470 | 6.3 | 28 | 10 | 60 | 3 | 1.658 | 1.492 | 0.663 | 0.099 | 0.090 | 0.040 |
| TPSE477*006T0100V | E | 470 | 6.3 | 28 | 10 | 100 | 3 | 1.285 | 1.156 | 0.514 | 0.128 | 0.116 | 0.051 |
| TPSE477*006T0200V | E | 470 | 6.3 | 28 | 10 | 200 | 3 | 0.908 | 0.817 | 0.363 | 0.182 | 0.163 | 0.073 |
| TPSE687*006T0045V | E | 680 | 6.3 | 42.8 | 10 | 45 | 3 | 1.915 | 1.723 | 0.766 | 0.086 | 0.078 | 0.034 |
| TPSE687*006T0060V | E | 680 | 6.3 | 42.8 | 10 | 60 | 3 | 1.658 | 1.492 | 0.663 | 0.099 | 0.090 | 0.040 |
| TPSE687*006T0100V | E | 680 | 6.3 | 42.8 | 10 | 100 | 3 | 1.285 | 1.156 | 0.514 | 0.128 | 0.116 | 0.051 |
| 10 Volt @ 85°C (7 Volt @ 125°C) | | | | | | | | | | | | | |
| TPSA225*010T1800 | A | 2.2 | 10 | 0.5 | 6 | 1800 | 1 | 0.204 | 0.184 | 0.082 | 0.367 | 0.331 | 0.147 |
| TPSA475*010T1400 | A | 4.7 | 10 | 0.5 | 6 | 1400 | 1 | 0.231 | 0.208 | 0.093 | 0.324 | 0.292 | 0.130 |
| TPSB475*010T1400 | B | 4.7 | 10 | 0.5 | 6 | 1400 | 1 | 0.246 | 0.222 | 0.099 | 0.345 | 0.310 | 0.138 |
| TPSA685*010T1800 | A | 6.8 | 10 | 0.7 | 6 | 1800 | 1 | 0.204 | 0.184 | 0.082 | 0.367 | 0.331 | 0.147 |
| TPSB685*010T1300 | B | 6.8 | 10 | 0.7 | 6 | 1300 | 1 | 0.256 | 0.230 | 0.102 | 0.332 | 0.299 | 0.133 |
| TPSA106*010T0900 | A | 10 | 10 | 1 | 6 | 900 | 1 | 0.289 | 0.260 | 0.115 | 0.260 | 0.234 | 0.104 |
| TPSA106*010T1800 | A | 10 | 10 | 1 | 6 | 1800 | 1 | 0.204 | 0.184 | 0.082 | 0.367 | 0.331 | 0.147 |
| TPSB106*010T1000 | B | 10 | 10 | 1 | 6 | 1000 | 1 | 0.292 | 0.262 | 0.117 | 0.292 | 0.262 | 0.117 |
| TPSA156*010T1000 | A | 15 | 10 | 1.5 | 6 | 1000 | 1 | 0.274 | 0.246 | 0.110 | 0.274 | 0.246 | 0.110 |
| TPSB156*010T0450 | B | 15 | 10 | 1.5 | 6 | 450 | 1 | 0.435 | 0.391 | 0.174 | 0.196 | 0.176 | 0.078 |
| TPSB156*010T0600 | B | 15 | 10 | 1.5 | 6 | 600 | 1 | 0.376 | 0.339 | 0.151 | 0.226 | 0.203 | 0.090 |
| TPSC156*010T0700 | C | 15 | 10 | 1.5 | 6 | 700 | 1 | 0.396 | 0.357 | 0.159 | 0.277 | 0.250 | 0.111 |
| TPSA226*010T0900 | A | 22 | 10 | 2.2 | 8 | 900 | 1 | 0.289 | 0.260 | 0.115 | 0.260 | 0.234 | 0.104 |
| TPSB226*010T0400 | B | 22 | 10 | 2.2 | 6 | 400 | 1 | 0.461 | 0.415 | 0.184 | 0.184 | 0.166 | 0.074 |
| TPSB226*010T0500 | B | 22 | 10 | 2.2 | 6 | 500 | 1 | 0.412 | 0.371 | 0.165 | 0.206 | 0.186 | 0.082 |
| TPSB226*010T0700 | B | 22 | 10 | 2.2 | 6 | 700 | 1 | 0.348 | 0.314 | 0.139 | 0.244 | 0.220 | 0.098 |

Moisture Sensitivity Level (MSL) is defined according to J-STD-020

*Please use "U" instead of "T" in the suffix letter for 13" reel packaging

Please use specific PN for automotive version - see "HOW TO ORDER".

All technical data relates to an ambient temperature of +25°C. Capacitance and DF are measured at 120Hz, 0.5V RMS with a maximum DC bias of 2.2 volts. DCL is measured at rated voltage after 5 minutes.

The EIA & CECC standards for low ESR Solid Tantalum Capacitors allow an ESR movement to 1.25 times catalogue limit post mounting.

For typical weight and composition see page 144.

NOTE: AVX reserves the right to supply a higher voltage rating or tighter tolerance part in the same case size, to the same reliability standards.



TPS Automotive Range

Low ESR - Automotive Product Range



RATINGS & PART NUMBER REFERENCE

| AVX Part No.* | Case Size | Capacitance (μF) | Rated Voltage (V) | DCL (μA) Max. | DF % Max. | ESR Max. (mΩ) @100kHz | MSL | 100kHz RMS Current (A) | | | 100kHz RMS Voltage (V) | | |
|--|-----------|------------------|-------------------|---------------|-----------|-----------------------|-----|------------------------|-------|-------|------------------------|-------|-------|
| | | | | | | | | 25°C | 85°C | 125°C | 25°C | 85°C | 125°C |
| TPSC226*010T0300 | C | 22 | 10 | 2.2 | 6 | 300 | 1 | 0.606 | 0.545 | 0.242 | 0.182 | 0.163 | 0.073 |
| TPSB336*010T0250 | B | 33 | 10 | 3.3 | 6 | 250 | 1 | 0.583 | 0.525 | 0.233 | 0.146 | 0.131 | 0.058 |
| TPSB336*010T0425 | B | 33 | 10 | 3.3 | 6 | 425 | 1 | 0.447 | 0.402 | 0.179 | 0.190 | 0.171 | 0.076 |
| TPSB336*010T0500 | B | 33 | 10 | 3.3 | 6 | 500 | 1 | 0.412 | 0.371 | 0.165 | 0.206 | 0.186 | 0.082 |
| TPSB336*010T0650 | B | 33 | 10 | 3.3 | 6 | 650 | 1 | 0.362 | 0.325 | 0.145 | 0.235 | 0.212 | 0.094 |
| TPSC336*010T0375 | C | 33 | 10 | 3.3 | 6 | 375 | 1 | 0.542 | 0.487 | 0.217 | 0.203 | 0.183 | 0.081 |
| TPSC336*010T0500 | C | 33 | 10 | 3.3 | 6 | 500 | 1 | 0.469 | 0.422 | 0.188 | 0.235 | 0.211 | 0.094 |
| TPSB476*010T0250 | B | 47 | 10 | 4.7 | 8 | 250 | 1 | 0.583 | 0.525 | 0.233 | 0.146 | 0.131 | 0.058 |
| TPSB476*010T0350 | B | 47 | 10 | 4.7 | 8 | 350 | 1 | 0.493 | 0.444 | 0.197 | 0.172 | 0.155 | 0.069 |
| TPSB476*010T0500 | B | 47 | 10 | 4.7 | 8 | 500 | 1 | 0.412 | 0.371 | 0.165 | 0.206 | 0.186 | 0.082 |
| TPSB476*010T0650 | B | 47 | 10 | 4.7 | 8 | 650 | 1 | 0.362 | 0.325 | 0.145 | 0.235 | 0.212 | 0.094 |
| TPSC476*010T0200 | C | 47 | 10 | 4.7 | 6 | 200 | 1 | 0.742 | 0.667 | 0.297 | 0.148 | 0.133 | 0.059 |
| TPSC476*010T0350 | C | 47 | 10 | 4.7 | 6 | 350 | 1 | 0.561 | 0.505 | 0.224 | 0.196 | 0.177 | 0.078 |
| TPSD476*010T0300V | D | 47 | 10 | 4.7 | 6 | 300 | 3 | 0.707 | 0.636 | 0.283 | 0.212 | 0.191 | 0.085 |
| TPSC686*010T0200 | C | 68 | 10 | 6.8 | 6 | 200 | 1 | 0.742 | 0.667 | 0.297 | 0.148 | 0.133 | 0.059 |
| TPSC686*010T0300 | C | 68 | 10 | 6.8 | 6 | 300 | 1 | 0.606 | 0.545 | 0.242 | 0.182 | 0.163 | 0.073 |
| TPSD686*010T0150V | D | 68 | 10 | 6.8 | 6 | 150 | 3 | 1.000 | 0.900 | 0.400 | 0.150 | 0.135 | 0.060 |
| TPSC107*010T0150 | C | 100 | 10 | 10 | 8 | 150 | 1 | 0.856 | 0.771 | 0.343 | 0.128 | 0.116 | 0.051 |
| TPSC107*010T0200 | C | 100 | 10 | 10 | 8 | 200 | 1 | 0.742 | 0.667 | 0.297 | 0.148 | 0.133 | 0.059 |
| TPSD107*010T0100V | D | 100 | 10 | 10 | 6 | 100 | 3 | 1.225 | 1.102 | 0.490 | 0.122 | 0.110 | 0.049 |
| TPSD107*010T0125V | D | 100 | 10 | 10 | 6 | 125 | 3 | 1.095 | 0.986 | 0.438 | 0.137 | 0.123 | 0.055 |
| TPSD107*010T0150V | D | 100 | 10 | 10 | 6 | 150 | 3 | 1.000 | 0.900 | 0.400 | 0.150 | 0.135 | 0.060 |
| TPSD157*010T0085V | D | 150 | 10 | 15 | 8 | 85 | 3 | 1.328 | 1.196 | 0.531 | 0.113 | 0.102 | 0.045 |
| TPSD157*010T0100V | D | 150 | 10 | 15 | 8 | 100 | 3 | 1.225 | 1.102 | 0.490 | 0.122 | 0.110 | 0.049 |
| TPSE157*010T0100V | E | 150 | 10 | 15 | 8 | 100 | 3 | 1.285 | 1.156 | 0.514 | 0.128 | 0.116 | 0.051 |
| TPSD227*010T0100V | D | 220 | 10 | 22 | 8 | 100 | 3 | 1.225 | 1.102 | 0.490 | 0.122 | 0.110 | 0.049 |
| TPSD227*010T0150V | D | 220 | 10 | 22 | 8 | 150 | 3 | 1.000 | 0.900 | 0.400 | 0.150 | 0.135 | 0.060 |
| TPSE227*010T0070V | E | 220 | 10 | 22 | 8 | 70 | 3 | 1.535 | 1.382 | 0.614 | 0.107 | 0.097 | 0.043 |
| TPSE227*010T0100V | E | 220 | 10 | 22 | 8 | 100 | 3 | 1.285 | 1.156 | 0.514 | 0.128 | 0.116 | 0.051 |
| TPSE227*010T0125V | E | 220 | 10 | 22 | 8 | 125 | 3 | 1.149 | 1.034 | 0.460 | 0.144 | 0.129 | 0.057 |
| TPSE227*010T0150V | E | 220 | 10 | 22 | 8 | 150 | 3 | 1.049 | 0.944 | 0.420 | 0.157 | 0.142 | 0.063 |
| TPSE337*010T0050V | E | 330 | 10 | 33 | 8 | 50 | 3 | 1.817 | 1.635 | 0.727 | 0.091 | 0.082 | 0.036 |
| TPSE337*010T0060V | E | 330 | 10 | 33 | 8 | 60 | 3 | 1.658 | 1.492 | 0.663 | 0.099 | 0.090 | 0.040 |
| TPSE337*010T0100V | E | 330 | 10 | 33 | 8 | 100 | 3 | 1.285 | 1.156 | 0.514 | 0.128 | 0.116 | 0.051 |
| 16 Volt @ 85°C (10 Volt @ 25°C) | | | | | | | | | | | | | |
| TPSA105*016T6200 | A | 1.0 | 16 | 0.5 | 4 | 6200 | 1 | 0.110 | 0.099 | 0.044 | 0.682 | 0.614 | 0.273 |
| TPSA225*016T1800 | A | 2.2 | 16 | 0.5 | 6 | 1800 | 1 | 0.204 | 0.184 | 0.082 | 0.367 | 0.331 | 0.147 |
| TPSA225*016T3500 | A | 2.2 | 16 | 0.5 | 6 | 3500 | 1 | 0.146 | 0.132 | 0.059 | 0.512 | 0.461 | 0.205 |
| TPSA335*016T3500 | A | 3.3 | 16 | 0.5 | 6 | 3500 | 1 | 0.146 | 0.132 | 0.059 | 0.512 | 0.461 | 0.205 |
| TPSB335*016T2500 | B | 3.3 | 16 | 0.5 | 6 | 2500 | 1 | 0.184 | 0.166 | 0.074 | 0.461 | 0.415 | 0.184 |
| TPSA475*016T2000 | A | 4.7 | 16 | 0.8 | 6 | 2000 | 1 | 0.194 | 0.174 | 0.077 | 0.387 | 0.349 | 0.155 |
| TPSB475*016T0800 | B | 4.7 | 16 | 0.8 | 6 | 800 | 1 | 0.326 | 0.293 | 0.130 | 0.261 | 0.235 | 0.104 |
| TPSB475*016T1500 | B | 4.7 | 16 | 0.8 | 6 | 1500 | 1 | 0.238 | 0.214 | 0.095 | 0.357 | 0.321 | 0.143 |
| TPSA685*016T1500 | A | 6.8 | 16 | 1.1 | 6 | 1500 | 1 | 0.224 | 0.201 | 0.089 | 0.335 | 0.302 | 0.134 |
| TPSB685*016T0600 | B | 6.8 | 16 | 1.1 | 6 | 600 | 1 | 0.376 | 0.339 | 0.151 | 0.226 | 0.203 | 0.090 |
| TPSB685*016T1200 | B | 6.8 | 16 | 1.1 | 6 | 1200 | 1 | 0.266 | 0.240 | 0.106 | 0.319 | 0.287 | 0.128 |
| TPSA106*016T1000 | A | 10 | 16 | 1.6 | 6 | 1000 | 1 | 0.274 | 0.246 | 0.110 | 0.274 | 0.246 | 0.110 |
| TPSB106*016T0500 | B | 10 | 16 | 1.6 | 6 | 500 | 1 | 0.412 | 0.371 | 0.165 | 0.206 | 0.186 | 0.082 |
| TPSB106*016T0800 | B | 10 | 16 | 1.6 | 6 | 800 | 1 | 0.326 | 0.293 | 0.130 | 0.261 | 0.235 | 0.104 |
| TPSC106*016T0500 | C | 10 | 16 | 1.6 | 6 | 500 | 1 | 0.469 | 0.422 | 0.188 | 0.235 | 0.211 | 0.094 |
| TPSB156*016T0500 | B | 15 | 16 | 2.4 | 6 | 500 | 1 | 0.412 | 0.371 | 0.165 | 0.206 | 0.186 | 0.082 |
| TPSB156*016T0800 | B | 15 | 16 | 2.4 | 6 | 800 | 1 | 0.326 | 0.293 | 0.130 | 0.261 | 0.235 | 0.104 |
| TPSC156*016T0700 | C | 15 | 16 | 2.4 | 6 | 700 | 1 | 0.396 | 0.357 | 0.159 | 0.277 | 0.250 | 0.111 |
| TPSB226*016T0400 | B | 22 | 16 | 3.5 | 6 | 400 | 1 | 0.461 | 0.415 | 0.184 | 0.184 | 0.166 | 0.074 |
| TPSB226*016T0600 | B | 22 | 16 | 3.5 | 6 | 600 | 1 | 0.376 | 0.339 | 0.151 | 0.226 | 0.203 | 0.090 |
| TPSC226*016T0300 | C | 22 | 16 | 3.5 | 6 | 300 | 1 | 0.606 | 0.545 | 0.242 | 0.182 | 0.163 | 0.073 |
| TPSC226*016T0375 | C | 22 | 16 | 3.5 | 6 | 375 | 1 | 0.542 | 0.487 | 0.217 | 0.203 | 0.183 | 0.081 |
| TPSD226*016T0700V | D | 22 | 16 | 3.5 | 6 | 700 | 3 | 0.463 | 0.417 | 0.185 | 0.324 | 0.292 | 0.130 |
| TPSC336*016T0225 | C | 33 | 16 | 5.3 | 6 | 225 | 1 | 0.699 | 0.629 | 0.280 | 0.157 | 0.142 | 0.063 |
| TPSC336*016T0300 | C | 33 | 16 | 5.3 | 6 | 300 | 1 | 0.606 | 0.545 | 0.242 | 0.182 | 0.163 | 0.073 |
| TPSD336*016T0200V | D | 33 | 16 | 5.3 | 6 | 200 | 3 | 0.866 | 0.779 | 0.346 | 0.173 | 0.156 | 0.069 |
| TPSC476*016T0350 | C | 47 | 16 | 7.5 | 6 | 350 | 1 | 0.561 | 0.505 | 0.224 | 0.196 | 0.177 | 0.078 |
| TPSD476*016T0200V | D | 47 | 16 | 7.5 | 6 | 200 | 3 | 0.866 | 0.779 | 0.346 | 0.173 | 0.156 | 0.069 |
| TPSC686*016T0200 | C | 68 | 16 | 10.9 | 6 | 200 | 1 | 0.742 | 0.667 | 0.297 | 0.148 | 0.133 | 0.059 |
| TPSD686*016T0150V | D | 68 | 16 | 10.9 | 6 | 150 | 3 | 1.000 | 0.900 | 0.400 | 0.150 | 0.135 | 0.060 |
| TPSD107*016T0100V | D | 100 | 16 | 16 | 6 | 100 | 3 | 1.225 | 1.102 | 0.490 | 0.122 | 0.110 | 0.049 |
| TPSD107*016T0125V | D | 100 | 16 | 16 | 6 | 125 | 3 | 1.095 | 0.986 | 0.438 | 0.137 | 0.123 | 0.055 |

Moisture Sensitivity Level (MSL) is defined according to J-STD-020

*Please use "U" instead of "T" in the suffix letter for 13" reel packaging

Please use specific PN for automotive version – see "HOW TO ORDER".

All technical data relates to an ambient temperature of +25°C. Capacitance and DF are measured at 120Hz, 0.5V RMS with a maximum DC bias of 2.2 volts. DCL is measured at rated voltage after 5 minutes.

The EIA & CECC standards for low ESR Solid Tantalum Capacitors allow an ESR movement to 1.25 times catalogue limit post mounting.

For typical weight and composition see page 144.

NOTE: AVX reserves the right to supply a higher voltage rating or tighter tolerance part in the same case size, to the same reliability standards.



TPS Automotive Range

Low ESR - Automotive Product Range



RATINGS & PART NUMBER REFERENCE

| AVX Part No.* | Case Size | Capacitance (µF) | Rated Voltage (V) | DCL (µA) Max. | DF % Max. | ESR Max. (mΩ) @100kHz | MSL | 100kHz RMS Current (A) | | | 100kHz RMS Voltage (V) | | |
|---|-----------|------------------|-------------------|---------------|-----------|-----------------------|-----|------------------------|-------|-------|------------------------|-------|-------|
| | | | | | | | | 25°C | 85°C | 125°C | 25°C | 85°C | 125°C |
| TPSD107*016T0150V | D | 100 | 16 | 16 | 6 | 150 | 3 | 1.000 | 0.900 | 0.400 | 0.150 | 0.135 | 0.060 |
| TPSE107*016T0100V | E | 100 | 16 | 16 | 6 | 100 | 3 | 1.285 | 1.156 | 0.514 | 0.128 | 0.116 | 0.051 |
| TPSE107*016T0125V | E | 100 | 16 | 16 | 6 | 125 | 3 | 1.149 | 1.034 | 0.460 | 0.144 | 0.129 | 0.057 |
| TPSE107*016T0150V | E | 100 | 16 | 16 | 6 | 150 | 3 | 1.049 | 0.944 | 0.420 | 0.157 | 0.142 | 0.063 |
| TPSE157*016T0100V | E | 150 | 16 | 23 | 8 | 100 | 3 | 1.285 | 1.156 | 0.514 | 0.128 | 0.116 | 0.051 |
| 20 Volt @ 85°C (13 Volt @ 125°C) | | | | | | | | | | | | | |
| TPSA105*020T3000 | A | 1 | 20 | 0.5 | 4 | 3000 | 1 | 0.158 | 0.142 | 0.063 | 0.474 | 0.427 | 0.190 |
| TPSA155*020T3000 | A | 1.5 | 20 | 0.5 | 6 | 3000 | 1 | 0.158 | 0.142 | 0.063 | 0.474 | 0.427 | 0.190 |
| TPSA225*020T3000 | A | 2.2 | 20 | 0.5 | 6 | 3000 | 1 | 0.158 | 0.142 | 0.063 | 0.474 | 0.427 | 0.190 |
| TPSB225*020T1700 | B | 2.2 | 20 | 0.5 | 6 | 1700 | 1 | 0.224 | 0.201 | 0.089 | 0.380 | 0.342 | 0.152 |
| TPSA335*020T2500 | A | 3.3 | 20 | 0.7 | 6 | 2500 | 1 | 0.173 | 0.156 | 0.069 | 0.433 | 0.390 | 0.173 |
| TPSB335*020T1300 | B | 3.3 | 20 | 0.7 | 6 | 1300 | 1 | 0.256 | 0.230 | 0.102 | 0.332 | 0.299 | 0.133 |
| TPSA475*020T1800 | A | 4.7 | 20 | 0.9 | 6 | 1800 | 1 | 0.204 | 0.184 | 0.082 | 0.367 | 0.331 | 0.147 |
| TPSB475*020T0750 | B | 4.7 | 20 | 0.9 | 6 | 750 | 1 | 0.337 | 0.303 | 0.135 | 0.252 | 0.227 | 0.101 |
| TPSB475*020T1000 | B | 4.7 | 20 | 0.9 | 6 | 1000 | 1 | 0.292 | 0.262 | 0.117 | 0.292 | 0.262 | 0.117 |
| TPSB685*020T0600 | B | 6.8 | 20 | 1.4 | 6 | 600 | 1 | 0.376 | 0.339 | 0.151 | 0.226 | 0.203 | 0.090 |
| TPSB685*020T1000 | B | 6.8 | 20 | 1.4 | 6 | 1000 | 1 | 0.292 | 0.262 | 0.117 | 0.292 | 0.262 | 0.117 |
| TPSC685*020T0700 | C | 6.8 | 20 | 1.4 | 6 | 700 | 1 | 0.396 | 0.357 | 0.159 | 0.277 | 0.250 | 0.111 |
| TPSB106*020T0500 | B | 10 | 20 | 2 | 6 | 500 | 1 | 0.412 | 0.371 | 0.165 | 0.206 | 0.186 | 0.082 |
| TPSB106*020T1000 | B | 10 | 20 | 2 | 6 | 1000 | 1 | 0.292 | 0.262 | 0.117 | 0.292 | 0.262 | 0.117 |
| TPSC106*020T0500 | C | 10 | 20 | 2 | 6 | 500 | 1 | 0.469 | 0.422 | 0.188 | 0.235 | 0.211 | 0.094 |
| TPSC106*020T0700 | C | 10 | 20 | 2 | 6 | 700 | 1 | 0.396 | 0.357 | 0.159 | 0.277 | 0.250 | 0.111 |
| TPSB156*020T0500 | B | 15 | 20 | 3 | 6 | 500 | 1 | 0.412 | 0.371 | 0.165 | 0.206 | 0.186 | 0.082 |
| TPSC156*020T0400 | C | 15 | 20 | 3 | 6 | 400 | 1 | 0.524 | 0.472 | 0.210 | 0.210 | 0.189 | 0.084 |
| TPSC156*020T0450 | C | 15 | 20 | 3 | 6 | 450 | 1 | 0.494 | 0.445 | 0.198 | 0.222 | 0.200 | 0.089 |
| TPSC226*020T0400 | C | 22 | 20 | 4.4 | 6 | 400 | 1 | 0.524 | 0.472 | 0.210 | 0.210 | 0.189 | 0.084 |
| TPSD226*020T0200V | D | 22 | 20 | 4.4 | 6 | 200 | 3 | 0.866 | 0.779 | 0.346 | 0.173 | 0.156 | 0.069 |
| TPSD226*020T0300V | D | 22 | 20 | 4.4 | 6 | 300 | 3 | 0.707 | 0.636 | 0.283 | 0.212 | 0.191 | 0.085 |
| TPSC336*020T0300 | C | 33 | 20 | 6.6 | 6 | 300 | 1 | 0.606 | 0.545 | 0.242 | 0.182 | 0.163 | 0.073 |
| TPSD336*020T0200V | D | 33 | 20 | 6.6 | 6 | 200 | 3 | 0.866 | 0.779 | 0.346 | 0.173 | 0.156 | 0.069 |
| TPSD476*020T0200V | D | 47 | 20 | 9.4 | 6 | 200 | 3 | 0.866 | 0.779 | 0.346 | 0.173 | 0.156 | 0.069 |
| TPSD686*020T0150V | D | 68 | 20 | 13.6 | 6 | 150 | 3 | 1.000 | 0.900 | 0.400 | 0.150 | 0.135 | 0.060 |
| TPSD686*020T0200V | D | 68 | 20 | 13.6 | 6 | 200 | 3 | 0.866 | 0.779 | 0.346 | 0.173 | 0.156 | 0.069 |
| TPSD686*020T0300V | D | 68 | 20 | 13.6 | 6 | 300 | 3 | 0.707 | 0.636 | 0.283 | 0.212 | 0.191 | 0.085 |
| TPSE686*020T0125V | E | 68 | 20 | 13.6 | 6 | 125 | 3 | 1.149 | 1.034 | 0.460 | 0.144 | 0.129 | 0.057 |
| TPSE686*020T0150V | E | 68 | 20 | 13.6 | 6 | 150 | 3 | 1.049 | 0.944 | 0.420 | 0.157 | 0.142 | 0.063 |
| TPSE686*020T0200V | E | 68 | 20 | 13.6 | 6 | 200 | 3 | 0.908 | 0.817 | 0.363 | 0.182 | 0.163 | 0.073 |
| TPSE107*020T0100V | E | 100 | 20 | 20 | 6 | 100 | 3 | 1.285 | 1.156 | 0.514 | 0.128 | 0.116 | 0.051 |
| TPSE107*020T0150V | E | 100 | 20 | 20 | 6 | 150 | 3 | 1.049 | 0.944 | 0.420 | 0.157 | 0.142 | 0.063 |
| TPSE107*020T0200V | E | 100 | 20 | 20 | 6 | 200 | 3 | 0.908 | 0.817 | 0.363 | 0.182 | 0.163 | 0.073 |
| 25 Volt @ 85°C (17 Volt @ 125°C) | | | | | | | | | | | | | |
| TPSA474*025T7000 | A | 0.47 | 25 | 0.5 | 4 | 7000 | 1 | 0.104 | 0.093 | 0.041 | 0.725 | 0.652 | 0.290 |
| TPSA684*025T6000 | A | 0.68 | 25 | 0.5 | 4 | 6000 | 1 | 0.112 | 0.101 | 0.045 | 0.671 | 0.604 | 0.268 |
| TPSA105*025T4000 | A | 1.0 | 25 | 0.5 | 4 | 4000 | 1 | 0.137 | 0.123 | 0.055 | 0.548 | 0.493 | 0.219 |
| TPSA155*025T3000 | A | 1.5 | 25 | 0.5 | 6 | 3000 | 1 | 0.158 | 0.142 | 0.063 | 0.474 | 0.427 | 0.190 |
| TPSA225*025T2500 | A | 2.2 | 25 | 0.6 | 6 | 2500 | 1 | 0.173 | 0.156 | 0.069 | 0.433 | 0.390 | 0.173 |
| TPSB225*025T0900 | B | 2.2 | 25 | 0.6 | 6 | 900 | 1 | 0.307 | 0.277 | 0.123 | 0.277 | 0.249 | 0.111 |
| TPSB225*025T1200 | B | 2.2 | 25 | 0.6 | 6 | 1200 | 1 | 0.266 | 0.240 | 0.106 | 0.319 | 0.287 | 0.128 |
| TPSB225*025T2500 | B | 2.2 | 25 | 0.6 | 6 | 2500 | 1 | 0.184 | 0.166 | 0.074 | 0.461 | 0.415 | 0.184 |
| TPSB335*025T0750 | B | 3.3 | 25 | 0.8 | 6 | 750 | 1 | 0.337 | 0.303 | 0.135 | 0.252 | 0.227 | 0.101 |
| TPSB335*025T1500 | B | 3.3 | 25 | 0.8 | 6 | 1500 | 1 | 0.238 | 0.214 | 0.095 | 0.357 | 0.321 | 0.143 |
| TPSB335*025T2000 | B | 3.3 | 25 | 0.8 | 6 | 2000 | 1 | 0.206 | 0.186 | 0.082 | 0.412 | 0.371 | 0.165 |
| TPSB475*025T0700 | B | 4.7 | 25 | 1.2 | 6 | 700 | 1 | 0.348 | 0.314 | 0.139 | 0.244 | 0.220 | 0.098 |
| TPSB475*025T0900 | B | 4.7 | 25 | 1.2 | 6 | 900 | 1 | 0.307 | 0.277 | 0.123 | 0.277 | 0.249 | 0.111 |
| TPSC475*025T0700 | C | 4.7 | 25 | 1.2 | 6 | 700 | 1 | 0.396 | 0.357 | 0.159 | 0.277 | 0.250 | 0.111 |
| TPSB685*025T0700 | B | 6.8 | 25 | 1.7 | 6 | 700 | 1 | 0.348 | 0.314 | 0.139 | 0.244 | 0.220 | 0.098 |
| TPSC685*025T0500 | C | 6.8 | 25 | 1.7 | 6 | 500 | 1 | 0.469 | 0.422 | 0.188 | 0.235 | 0.211 | 0.094 |
| TPSC685*025T0600 | C | 6.8 | 25 | 1.7 | 6 | 600 | 1 | 0.428 | 0.385 | 0.171 | 0.257 | 0.231 | 0.103 |
| TPSC685*025T0700 | C | 6.8 | 25 | 1.7 | 6 | 700 | 1 | 0.396 | 0.357 | 0.159 | 0.277 | 0.250 | 0.111 |
| TPSC106*025T0300 | C | 10 | 25 | 2.5 | 6 | 300 | 1 | 0.606 | 0.545 | 0.242 | 0.182 | 0.163 | 0.073 |
| TPSC106*025T0500 | C | 10 | 25 | 2.5 | 6 | 500 | 1 | 0.469 | 0.422 | 0.188 | 0.235 | 0.211 | 0.094 |
| TPSD106*025T0500V | D | 10 | 25 | 2.5 | 6 | 500 | 3 | 0.548 | 0.493 | 0.219 | 0.274 | 0.246 | 0.110 |
| TPSC156*025T0220 | C | 15 | 25 | 3.8 | 6 | 220 | 1 | 0.707 | 0.636 | 0.283 | 0.156 | 0.140 | 0.062 |
| TPSC156*025T0300 | C | 15 | 25 | 3.8 | 6 | 300 | 1 | 0.606 | 0.545 | 0.242 | 0.182 | 0.163 | 0.073 |
| TPSD156*025T0300V | D | 15 | 25 | 3.8 | 6 | 300 | 3 | 0.707 | 0.636 | 0.283 | 0.212 | 0.191 | 0.085 |
| TPSC226*025T0275 | C | 22 | 25 | 5.5 | 6 | 275 | 1 | 0.632 | 0.569 | 0.253 | 0.174 | 0.157 | 0.070 |
| TPSC226*025T0400 | C | 22 | 25 | 5.5 | 6 | 400 | 1 | 0.524 | 0.472 | 0.210 | 0.210 | 0.189 | 0.084 |

Moisture Sensitivity Level (MSL) is defined according to J-STD-020

*Please use "U" instead of "T" in the suffix letter for 13" reel packaging

Please use specific PN for automotive version - see "HOW TO ORDER".

All technical data relates to an ambient temperature of +25°C. Capacitance and DF are measured at 120Hz, 0.5V RMS with a maximum DC bias of 2.2 volts. DCL is measured at rated voltage after 5 minutes.

The EIA & CECC standards for low ESR Solid Tantalum Capacitors allow an ESR movement to 1.25 times catalogue limit post mounting.

For typical weight and composition see page 144.

NOTE: AVX reserves the right to supply a higher voltage rating or tighter tolerance part in the same case size, to the same reliability standards.



TPS Automotive Range



Low ESR - Automotive Product Range

RATINGS & PART NUMBER REFERENCE

| AVX Part No.* | Case Size | Capacitance (µF) | Rated Voltage (V) | DCL (µA) Max. | DF % Max. | ESR Max. (mΩ) @100kHz | MSL | 100kHz RMS Current (A) | | | 100kHz RMS Voltage (V) | | |
|---|-----------|------------------|-------------------|---------------|-----------|-----------------------|-----|------------------------|-------|-------|------------------------|-------|-------|
| | | | | | | | | 25°C | 85°C | 125°C | 25°C | 85°C | 125°C |
| TPSD226*025T0200V | D | 22 | 25 | 5.5 | 6 | 200 | 3 | 0.866 | 0.779 | 0.346 | 0.173 | 0.156 | 0.069 |
| TPSD226*025T0300V | D | 22 | 25 | 5.5 | 6 | 300 | 3 | 0.707 | 0.636 | 0.283 | 0.212 | 0.191 | 0.085 |
| TPSD336*025T0200V | D | 33 | 25 | 8.3 | 6 | 200 | 3 | 0.866 | 0.779 | 0.346 | 0.173 | 0.156 | 0.069 |
| TPSD336*025T0300V | D | 33 | 25 | 8.3 | 6 | 300 | 3 | 0.707 | 0.636 | 0.283 | 0.212 | 0.191 | 0.085 |
| TPSD476*025T0125V | D | 47 | 25 | 11.8 | 6 | 125 | 3 | 1.095 | 0.986 | 0.438 | 0.137 | 0.123 | 0.055 |
| TPSD476*025T0150V | D | 47 | 25 | 11.8 | 6 | 150 | 3 | 1.000 | 0.900 | 0.400 | 0.150 | 0.135 | 0.060 |
| TPSD476*025T0250V | D | 47 | 25 | 11.8 | 6 | 250 | 3 | 0.775 | 0.697 | 0.310 | 0.194 | 0.174 | 0.077 |
| TPSE476*025T0125V | E | 47 | 25 | 11.8 | 6 | 125 | 3 | 1.149 | 1.034 | 0.460 | 0.144 | 0.129 | 0.057 |
| 35 Volt @ 85°C (23 Volt @ 125°C) | | | | | | | | | | | | | |
| TPSA334*035T6000 | A | 0.33 | 35 | 0.5 | 4 | 6000 | 1 | 0.112 | 0.101 | 0.045 | 0.671 | 0.604 | 0.268 |
| TPSA474*035T6000 | A | 0.47 | 35 | 0.5 | 4 | 6000 | 1 | 0.112 | 0.101 | 0.045 | 0.671 | 0.604 | 0.268 |
| TPSA684*035T6000 | A | 0.68 | 35 | 0.5 | 4 | 6000 | 1 | 0.112 | 0.101 | 0.045 | 0.671 | 0.604 | 0.268 |
| TPSA105*035T3000 | A | 1 | 35 | 0.5 | 4 | 3000 | 1 | 0.158 | 0.142 | 0.063 | 0.474 | 0.427 | 0.190 |
| TPSB105*035T2000 | B | 1 | 35 | 0.5 | 4 | 2000 | 1 | 0.206 | 0.186 | 0.082 | 0.412 | 0.371 | 0.165 |
| TPSA155*035T3000 | A | 1.5 | 35 | 0.5 | 6 | 3000 | 1 | 0.158 | 0.142 | 0.063 | 0.474 | 0.427 | 0.190 |
| TPSB155*035T2500 | B | 1.5 | 35 | 0.5 | 6 | 2500 | 1 | 0.184 | 0.166 | 0.074 | 0.461 | 0.415 | 0.184 |
| TPSB225*035T0750 | B | 2.2 | 35 | 0.8 | 6 | 750 | 1 | 0.337 | 0.303 | 0.135 | 0.252 | 0.227 | 0.101 |
| TPSB225*035T1500 | B | 2.2 | 35 | 0.8 | 6 | 1500 | 1 | 0.238 | 0.214 | 0.095 | 0.357 | 0.321 | 0.143 |
| TPSB225*035T2000 | B | 2.2 | 35 | 0.8 | 6 | 2000 | 1 | 0.206 | 0.186 | 0.082 | 0.412 | 0.371 | 0.165 |
| TPSC225*035T1000 | C | 2.2 | 35 | 0.8 | 6 | 1000 | 1 | 0.332 | 0.298 | 0.133 | 0.332 | 0.298 | 0.133 |
| TPSB335*035T1000 | B | 3.3 | 35 | 1.2 | 6 | 1000 | 1 | 0.292 | 0.262 | 0.117 | 0.292 | 0.262 | 0.117 |
| TPSC335*035T0700 | C | 3.3 | 35 | 1.2 | 6 | 700 | 1 | 0.396 | 0.357 | 0.159 | 0.277 | 0.250 | 0.111 |
| TPSB475*035T0700 | B | 4.7 | 35 | 1.6 | 6 | 700 | 1 | 0.348 | 0.314 | 0.139 | 0.244 | 0.220 | 0.098 |
| TPSB475*035T1500 | B | 4.7 | 35 | 1.6 | 6 | 1500 | 1 | 0.238 | 0.214 | 0.095 | 0.357 | 0.321 | 0.143 |
| TPSC475*035T0600 | C | 4.7 | 35 | 1.6 | 6 | 600 | 1 | 0.428 | 0.385 | 0.171 | 0.257 | 0.231 | 0.103 |
| TPSD475*035T0700V | D | 4.7 | 35 | 1.6 | 6 | 700 | 3 | 0.463 | 0.417 | 0.185 | 0.324 | 0.292 | 0.130 |
| TPSC685*035T0350 | C | 6.8 | 35 | 2.4 | 6 | 350 | 1 | 0.561 | 0.505 | 0.224 | 0.196 | 0.177 | 0.078 |
| TPSD685*035T0400V | D | 6.8 | 35 | 2.4 | 6 | 400 | 3 | 0.612 | 0.551 | 0.245 | 0.245 | 0.220 | 0.098 |
| TPSD685*035T0500V | D | 6.8 | 35 | 2.4 | 6 | 500 | 3 | 0.548 | 0.493 | 0.219 | 0.274 | 0.246 | 0.110 |
| TPSC106*035T0600 | C | 10 | 35 | 3.5 | 6 | 600 | 1 | 0.428 | 0.385 | 0.171 | 0.257 | 0.231 | 0.103 |
| TPSD106*035T0300V | D | 10 | 35 | 3.5 | 6 | 300 | 3 | 0.707 | 0.636 | 0.283 | 0.212 | 0.191 | 0.085 |
| TPSD156*035T0300V | D | 15 | 35 | 5.3 | 6 | 300 | 3 | 0.707 | 0.636 | 0.283 | 0.212 | 0.191 | 0.085 |
| TPSD226*035T0200V | D | 22 | 35 | 7.7 | 6 | 200 | 3 | 0.866 | 0.779 | 0.346 | 0.173 | 0.156 | 0.069 |
| TPSD226*035T0300V | D | 22 | 35 | 7.7 | 6 | 300 | 3 | 0.707 | 0.636 | 0.283 | 0.212 | 0.191 | 0.085 |
| TPSD226*035T0400V | D | 22 | 35 | 7.7 | 6 | 400 | 3 | 0.612 | 0.551 | 0.245 | 0.245 | 0.220 | 0.098 |
| TPSE226*035T0200V | E | 22 | 35 | 7.7 | 6 | 200 | 3 | 0.908 | 0.817 | 0.363 | 0.182 | 0.163 | 0.073 |
| TPSE226*035T0300V | E | 22 | 35 | 7.7 | 6 | 300 | 3 | 0.742 | 0.667 | 0.297 | 0.222 | 0.200 | 0.089 |
| TPSE336*035T0250V | E | 33 | 35 | 11.6 | 6 | 250 | 3 | 0.812 | 0.731 | 0.325 | 0.203 | 0.183 | 0.081 |
| TPSE336*035T0300V | E | 33 | 35 | 11.6 | 6 | 300 | 3 | 0.742 | 0.667 | 0.297 | 0.222 | 0.200 | 0.089 |
| 50 Volt @ 85°C (33 Volt @ 125°C) | | | | | | | | | | | | | |
| TPSA224*050T7000 | A | 0.22 | 50 | 0.5 | 4 | 7000 | 1 | 0.104 | 0.093 | 0.041 | 0.725 | 0.652 | 0.290 |
| TPSA334*050T7000 | A | 0.33 | 50 | 0.5 | 4 | 7000 | 1 | 0.104 | 0.093 | 0.041 | 0.725 | 0.652 | 0.290 |
| TPSA474*050T6500 | A | 0.47 | 50 | 0.5 | 4 | 6500 | 1 | 0.107 | 0.097 | 0.043 | 0.698 | 0.628 | 0.279 |
| TPSB474*050T6000 | B | 0.47 | 50 | 0.5 | 4 | 6000 | 1 | 0.119 | 0.107 | 0.048 | 0.714 | 0.643 | 0.286 |
| TPSB684*050T4000 | B | 0.68 | 50 | 0.5 | 4 | 4000 | 1 | 0.146 | 0.131 | 0.058 | 0.583 | 0.525 | 0.233 |
| TPSB105*050T3000 | B | 1 | 50 | 0.5 | 6 | 3000 | 1 | 0.168 | 0.151 | 0.067 | 0.505 | 0.454 | 0.202 |
| TPSC105*050T2500 | C | 1 | 50 | 0.5 | 4 | 2500 | 1 | 0.210 | 0.189 | 0.084 | 0.524 | 0.472 | 0.210 |
| TPSC155*050T1500 | C | 1.5 | 50 | 0.8 | 6 | 1500 | 1 | 0.271 | 0.244 | 0.108 | 0.406 | 0.366 | 0.162 |
| TPSC155*050T2000 | C | 1.5 | 50 | 0.8 | 6 | 2000 | 1 | 0.235 | 0.211 | 0.094 | 0.469 | 0.422 | 0.188 |
| TPSC225*050T1500 | C | 2.2 | 50 | 1.1 | 8 | 1500 | 1 | 0.271 | 0.244 | 0.108 | 0.406 | 0.366 | 0.162 |
| TPSD225*050T1200V | D | 2.2 | 50 | 1.1 | 6 | 1200 | 3 | 0.354 | 0.318 | 0.141 | 0.424 | 0.382 | 0.170 |
| TPSC335*050T1000 | C | 3.3 | 50 | 1.6 | 6 | 1000 | 1 | 0.332 | 0.298 | 0.133 | 0.332 | 0.298 | 0.133 |
| TPSD335*050T0800V | D | 3.3 | 50 | 1.7 | 6 | 800 | 3 | 0.433 | 0.390 | 0.173 | 0.346 | 0.312 | 0.139 |
| TPSC475*050T0800 | C | 4.7 | 50 | 2.4 | 6 | 800 | 1 | 0.371 | 0.334 | 0.148 | 0.297 | 0.267 | 0.119 |
| TPSD475*050T0500V | D | 4.7 | 50 | 2.4 | 6 | 500 | 3 | 0.548 | 0.493 | 0.219 | 0.274 | 0.246 | 0.110 |
| TPSD475*050T0700V | D | 4.7 | 50 | 2.4 | 6 | 700 | 3 | 0.463 | 0.417 | 0.185 | 0.324 | 0.292 | 0.130 |
| TPSD685*050T0500V | D | 6.8 | 50 | 3.4 | 6 | 500 | 3 | 0.548 | 0.493 | 0.219 | 0.274 | 0.246 | 0.110 |
| TPSD685*050T0600V | D | 6.8 | 50 | 3.4 | 6 | 600 | 3 | 0.500 | 0.450 | 0.200 | 0.300 | 0.270 | 0.120 |
| TPSD106*050T0500V | D | 10 | 50 | 5 | 6 | 500 | 3 | 0.548 | 0.493 | 0.219 | 0.274 | 0.246 | 0.110 |
| TPSE106*050T0250V | E | 10 | 50 | 5 | 6 | 250 | 3 | 0.812 | 0.731 | 0.325 | 0.203 | 0.183 | 0.081 |
| TPSE106*050T0300V | E | 10 | 50 | 5 | 6 | 300 | 3 | 0.742 | 0.667 | 0.297 | 0.222 | 0.200 | 0.089 |
| TPSE106*050T0400V | E | 10 | 50 | 5 | 6 | 400 | 3 | 0.642 | 0.578 | 0.257 | 0.257 | 0.231 | 0.103 |
| TPSE106*050T0500V | E | 10 | 50 | 5 | 6 | 500 | 3 | 0.574 | 0.517 | 0.230 | 0.287 | 0.259 | 0.115 |
| TPSE156*050T0250V | E | 15 | 50 | 7.5 | 6 | 250 | 3 | 0.812 | 0.731 | 0.325 | 0.203 | 0.183 | 0.081 |

Moisture Sensitivity Level (MSL) is defined according to J-STD-020

*Please use "U" instead of "T" in the suffix letter for 13" reel packaging

Please use specific PN for automotive version - see "HOW TO ORDER".

All technical data relates to an ambient temperature of +25°C. Capacitance and DF are measured at 120Hz, 0.5V RMS with a maximum DC bias of 2.2 volts. DCL is measured at rated voltage after 5 minutes.

The EIA & CECC standards for low ESR Solid Tantalum Capacitors allow an ESR movement to 1.25 times catalogue limit post mounting.

For typical weight and composition see page 144.

NOTE: AVX reserves the right to supply a higher voltage rating or tighter tolerance part in the same case size, to the same reliability standards.



F91 Series



Low ESR, Resin-Molded Chip J-Lead



For SMD



For High Frequency

- Compliant to the RoHS directive (2002/95/EC).

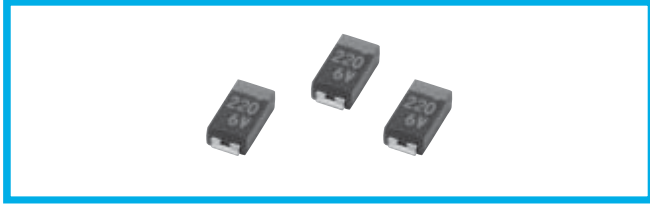

Type numbering system (Example: 10V 100μF)

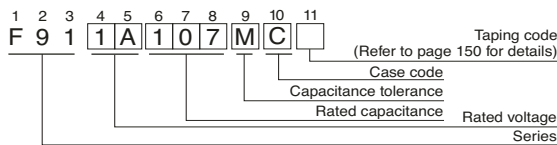

Drawing

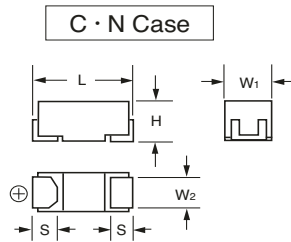

Dimensions

| Case Code | L | W ₁ | W ₂ | H | S |
|-----------|-----------|----------------|----------------|-----------|-----------|
| C | 6.0 ± 0.2 | 3.2 ± 0.2 | 2.2 ± 0.1 | 2.5 ± 0.2 | 1.3 ± 0.2 |
| N | 7.3 ± 0.2 | 4.3 ± 0.2 | 2.4 ± 0.1 | 2.8 ± 0.2 | 1.3 ± 0.2 |

Marking

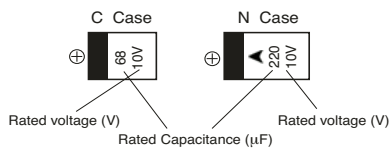

Standard Ratings

| Cap. (μF) | Code | V | | |
|-----------|------|---|-------|----|
| | | 4 | 6.3 | 10 |
| 68 | 686 | | | C |
| 100 | 107 | | C | C |
| 150 | 157 | C | C | N |
| 220 | 227 | C | C · N | N |
| 330 | 337 | N | N | N |
| 470 | 477 | N | N | |
| 680 | 687 | N | | |

Specifications

| Item | Performance Characteristics |
|-----------------------------------|---|
| Category | |
| Temperature Range | -55 to +125°C (Rated temperature : +85°C) |
| Capacitance Tolerance | ±20%, ±10% (at 120Hz) |
| Dissipation Factor (120Hz) | Refer to the table below. |
| ESR (100kHz) | Refer to the table below. |
| Leakage Current | <ul style="list-style-type: none"> After 1 minute's application of rated voltage, leakage current at 20°C is not more than 0.01CV or 0.5μA, whichever is greater. After 1 minute's application of rated voltage, leakage current at 85°C is not more than 0.1CV or 5μA, whichever is greater. After 1 minute's application of derated voltage, leakage current at 125°C is not more than 0.125CV or 6.3μA, whichever is greater. |
| Capacitance Change by Temperature | +15% Max. (at +125°C) +10% Max. (at +85°C) -10% Max. (at -55°C) |
| Damp Heat (Steady State) | At 40°C 90 to 95% R.H. 500 hours (No voltage applied) Capacitance Change Within ±10% of the initial value Dissipation Factor.....Initial specified value or less Leakage Current.....Initial specified value or less |
| Temperature Cycles | -55°C / +125°C 30 minutes each 5 cycles Capacitance Change Within ±5% of the initial value Dissipation Factor.....Initial specified value or less Leakage Current.....Initial specified value or less |
| Resistance to Soldering Heat | 10 seconds reflow at 260°C, 5 seconds immersion at 260°C Capacitance Change Within ±5% of the initial value Dissipation Factor.....Initial specified value or less Leakage Current.....Initial specified value or less |
| Surge | After application of surge in series with a 33Ω resistor at the rate of 30 seconds ON, 30 seconds OFF, for 1000 successive test cycles at 85°C, capacitors shall meet the characteristic requirements table below. Capacitance Change.....Within ±5% of the initial value Dissipation Factor.....Initial specified value or less Leakage Current.....Initial specified value or less |
| Endurance | After 2000 hours' application of rated voltage in series with a 3Ω resistor at 85°C, or derated voltage in series with a 3Ω resistor at 125°C, capacitors shall meet the characteristics requirements table below. Capacitance Change.....Within ±10% of the initial value Dissipation Factor.....Initial specified value or less Leakage Current.....Initial specified value or less |
| Shear Test | After applying the pressure load of 5N for 10±1 seconds horizontally to the center of capacitor side body which has no electrode and has been soldered beforehand on a substrate, there shall be found neither exfoliation nor its sign at the terminal electrode. 5N (0.51 kg · f) For 10±1 seconds |
| Terminal Strength | Keeping a capacitor surface-mounted on a substrate upside down and supporting the substrate at both of the opposite bottom points 45mm apart from the center of capacitor, the pressure strength is applied with a specified jig at the center of substrate so that the substrate may bend by 1mm as illustrated. Then, there shall be found no remarkable abnormality on the capacitor terminals. R230 20 45 45 1mm |

| Rated Volt | Rated Capacitance (μF) | Case code | Part Number | Leakage Current (μA) | Dissipation Factor (% @120Hz) | ESR (mΩ @100kHz) |
|------------|------------------------|-----------|-------------|----------------------|-------------------------------|------------------|
| 4V | 150 | C | F910G157MCC | 6.0 | 12 | 250 |
| | 220 | C | F910G227MCC | 8.8 | 12 | 250 |
| | 330 | N | F910G337MNC | 13.2 | 10 | 100 |
| | 470 | N | F910G477MNC | 18.8 | 16 | 100 |
| | 680 | N | F910G687MNC | 27.2 | 18 | 100 |
| 6.3V | 100 | C | F910J107MCC | 6.3 | 8 | 250 |
| | 150 | C | F910J157MCC | 9.5 | 12 | 250 |
| | 220 | C | F910J227MCC | 13.9 | 14 | 250 |
| | 220 | N | F910J227MNC | 13.9 | 10 | 100 |
| | 330 | N | F910J337MNC | 20.8 | 14 | 100 |
| | 470 | N | F910J477MNC | 29.6 | 16 | 100 |
| 10V | 68 | C | F911A686MCC | 6.8 | 8 | 300 |
| | 100 | C | F911A107MCC | 10.0 | 10 | 250 |
| | 150 | N | F911A157MNC | 15.0 | 10 | 100 |
| | 220 | N | F911A227MNC | 22.0 | 12 | 100 |
| | 330 | N | F911A337MNC | 33.0 | 18 | 100 |

* In case of capacitance tolerance ± 10% type, [K] will be put at 9th digit of type numbering system.

TPM Multianode



Tantalum Ultra Low ESR Capacitor



- Multi-anode construction
- Super low ESR
- CV range: 10-2200 μ F / 2.5-50V
- 4 case sizes available
- "Mirror" multi-anode construction used with D case capacitors reduces ESL to half



SnPb termination option is not RoHS compliant.

MULTIANODE CONSTRUCTION

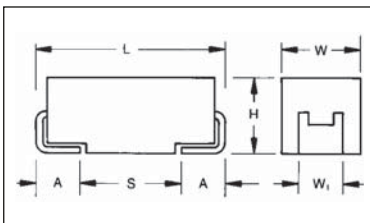
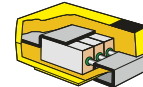

For part marking see page 151

CASE DIMENSIONS: millimeters (inches)

| Code | EIA Code | EIA Metric | L \pm 0.20 (0.008) | W+0.20 (0.008) -0.10 (0.004) | H+0.20 (0.008) -0.10 (0.004) | W \pm 0.20 (0.008) | A+0.30 (0.012) -0.20 (0.008) | S Min. |
|------|----------|------------|----------------------|------------------------------|------------------------------|----------------------|------------------------------|--------------|
| D | 2917 | 7343-31 | 7.30 (0.287) | 4.30 (0.169) | 2.90 (0.114) | 2.40 (0.094) | 1.30 (0.051) | 4.40 (0.173) |
| E | 2917 | 7343-43 | 7.30 (0.287) | 4.30 (0.169) | 4.10 (0.162) | 2.40 (0.094) | 1.30 (0.051) | 4.40 (0.173) |
| V | 2924 | 7361-38 | 7.30 (0.287) | 6.10 (0.240) | 3.55 (0.140) | 3.10 (0.120) | 1.30 (0.051) | 4.40 (0.173) |
| Y | 2917 | 7343-20 | 7.30 (0.287) | 4.30 (0.169) | 2.00 (0.079) max | 2.40 (0.094) | 1.30 (0.051) | 4.40 (0.173) |

W1 dimension applies to the termination width for A dimensional area only.

HOW TO ORDER

TPM

Type

E

Case Size
See table above

108

Capacitance Code
pF code: 1st two digits represent significant figures, 3rd digit represents multiplier (number of zeros to follow)

M

Tolerance
K=±10%
M=±20%

004

Rated DC Voltage
002=2.5Vdc
004=4Vdc
006=6.3Vdc
010=10Vdc
016=16Vdc
020=20Vdc
025=25Vdc
035=35Vdc
050=50Vdc

R

Packaging
R = Pure Tin 7" Reel
S = Pure Tin 13" Reel
H = Tin Lead 7" Reel (Contact Manufacturer)
K = Tin Lead 13" Reel (Contact Manufacturer)
H, K = Non RoHS

0018

ESR in m Ω

TECHNICAL SPECIFICATIONS

| | | | | | | | | | | |
|----------------------------|--|-----|-----|-----|----|----|----|----|----|----|
| Technical Data: | All technical data relate to an ambient temperature of +25°C | | | | | | | | | |
| Capacitance Range: | 10 μ F to 2200 μ F | | | | | | | | | |
| Capacitance Tolerance: | \pm 10%, \pm 20% | | | | | | | | | |
| Rated Voltage (V_R) | \leq +85°C: | 2.5 | 4 | 6.3 | 10 | 16 | 20 | 25 | 35 | 50 |
| Category Voltage (V_C) | \leq +125°C: | 1.7 | 2.7 | 4 | 7 | 10 | 13 | 17 | 23 | 33 |
| Surge Voltage (V_S) | \leq +85°C: | 3.3 | 5.2 | 8 | 13 | 20 | 26 | 32 | 46 | 65 |
| Surge Voltage (V_S) | \leq +125°C: | 2.2 | 3.4 | 5 | 8 | 13 | 16 | 20 | 28 | 40 |
| Temperature Range: | -55°C to +125°C | | | | | | | | | |
| Reliability: | 1% per 1000 hours at 85°C, V_R with 0.1 Ω /V series impedance, 60% confidence level | | | | | | | | | |

TPM Multianode



Tantalum Ultra Low ESR Capacitor

CAPACITANCE AND RATED VOLTAGE, VR (VOLTAGE CODE) RANGE (LETTER DENOTES CASE SIZE)

| Capacitance | | Rated Voltage DC (V _R) to 85°C | | | | | | | | |
|-------------|------|--|-----------------------------|--|----------------------|----------|----------|-------------|--------------------|------------------|
| μF | Code | 2.5V (e) | 4V (G) | 6.3V (J) | 10V (A) | 16V (C) | 20V (D) | 25V (E) | 35V (V) | 50V (T) |
| 6.8 | 685 | | | | | | | | | |
| 10 | 106 | | | | | | | | | D(140) E(120) |
| 15 | 156 | | | | | | | | | E(75,100) |
| 22 | 226 | | | | | | | | D(70) E(60,100) | E(75,100) |
| 33 | 336 | | | | | | | D(65) | E(50,65) | |
| 47 | 476 | | | | | | D(45,55) | D(55)/E(65) | E(55,65) | |
| 68 | 686 | | | | | D(40,50) | | E(45,55) | | |
| 100 | 107 | | | | Y(45) ^(M) | D(40,50) | E(35,45) | | | |
| 150 | 157 | | | | Y(45) ^(M) | E(30,40) | E(35) | | | |
| 220 | 227 | | | Y(30) ^(M) | D(35) | E(25,40) | | | | |
| 330 | 337 | | D(25,35) | D(25,35) | D(35) E(23,35) | E(50) | | | | |
| 470 | 477 | | D(25,35) | D(30) E(18,23,30) | E(23,30) | | | | | |
| 680 | 687 | | D(25) E(18,23) | E(18,23) V(23) | | | | | | |
| 1000 | 108 | D(25) | D(25,45) E(18,23), V(18) | E(25) ^(M) V(20) ^(M) | | | | | | |
| 1500 | 158 | E(12,15,18) | E(15,18) | | | | | | | |
| 2200 | 228 | E(18) ^(M) | | | | | | | | |

Released codes ^(M tolerance only)

Engineering samples - please contact manufacturer

*Codes under development - subject to change

Note: Voltage ratings are minimum values. AVX reserves the right to supply higher ratings in the same case size, to the same reliability standards.

TPM Multianode



Tantalum Ultra Low ESR Capacitor

RATINGS & PART NUMBER REFERENCE

| AVX Part No. | Case Size | Capacitance (µF) | Rated Voltage (V) | DCL (µA) Max. | DF % Max. | ESR Max. (mΩ) @100kHz | MSL | 100kHz RMS Current (A) | | | 100kHz RMS Voltage (V) | | |
|---|-----------|------------------|-------------------|---------------|-----------|-----------------------|-----|------------------------|-------|-------|------------------------|-------|-------|
| | | | | | | | | 25°C | 85°C | 125°C | 25°C | 85°C | 125°C |
| 2.5 Volt @ 85°C (1.7 Volt @ 125°C) | | | | | | | | | | | | | |
| TPMD108*002#0025 | D | 1000 | 2.5 | 25 | 8 | 25 | 3 | 3.194 | 2.874 | 1.277 | 0.080 | 0.072 | 0.032 |
| TPME158*002#0012 | E | 1500 | 2.5 | 38 | 6 | 12 | 3 | 4.743 | 4.269 | 1.897 | 0.057 | 0.051 | 0.023 |
| TPME158*002#0015 | E | 1500 | 2.5 | 38 | 6 | 15 | 3 | 4.243 | 3.818 | 1.697 | 0.064 | 0.057 | 0.025 |
| TPME158*002#0018 | E | 1500 | 2.5 | 38 | 6 | 18 | 3 | 3.873 | 3.486 | 1.549 | 0.070 | 0.063 | 0.028 |
| TPME228M002#0018 | E | 2200 | 2.5 | 44 | 10 | 18 | 3 | 3.873 | 3.486 | 1.549 | 0.070 | 0.063 | 0.028 |
| 4 Volt @ 85°C (2.7 Volt @ 125°C) | | | | | | | | | | | | | |
| TPMD337*004#0025 | D | 330 | 4 | 13.2 | 8 | 25 | 3 | 3.194 | 2.874 | 1.277 | 0.080 | 0.072 | 0.032 |
| TPMD337*004#0035 | D | 330 | 4 | 13.2 | 8 | 35 | 3 | 2.699 | 2.429 | 1.080 | 0.094 | 0.085 | 0.038 |
| TPMD477*004#0025 | D | 470 | 4 | 18.8 | 8 | 25 | 3 | 3.194 | 2.874 | 1.277 | 0.080 | 0.072 | 0.032 |
| TPMD477*004#0035 | D | 470 | 4 | 18.8 | 8 | 35 | 3 | 2.699 | 2.429 | 1.080 | 0.094 | 0.085 | 0.038 |
| TPMD687*004#0025 | D | 680 | 4 | 27.2 | 8 | 25 | 3 | 3.194 | 2.874 | 1.277 | 0.080 | 0.072 | 0.032 |
| TPME687*004#0018 | E | 680 | 4 | 27 | 6 | 18 | 3 | 3.873 | 3.486 | 1.549 | 0.070 | 0.063 | 0.028 |
| TPME687*004#0023 | E | 680 | 4 | 27 | 6 | 23 | 3 | 3.426 | 3.084 | 1.370 | 0.079 | 0.071 | 0.032 |
| TPMD108*004#0025 | D | 1000 | 4 | 40 | 8 | 25 | 3 | 3.194 | 2.874 | 1.277 | 0.080 | 0.072 | 0.032 |
| TPMD108*004#0045 | D | 1000 | 4 | 40 | 8 | 45 | 3 | 2.380 | 2.142 | 0.952 | 0.107 | 0.096 | 0.043 |
| TPME108*004#0018 | E | 1000 | 4 | 40 | 6 | 18 | 3 | 3.873 | 3.486 | 1.549 | 0.070 | 0.063 | 0.028 |
| TPME108*004#0023 | E | 1000 | 4 | 40 | 6 | 23 | 3 | 3.426 | 3.084 | 1.370 | 0.079 | 0.071 | 0.032 |
| TPMV108*004#0018 | V | 1000 | 4 | 40 | 6 | 18 | 3 | 3.979 | 3.581 | 1.592 | 0.072 | 0.064 | 0.029 |
| TPME158*004#0015 | E | 1500 | 4 | 40 | 6 | 15 | 3 | 4.243 | 3.818 | 1.697 | 0.064 | 0.057 | 0.025 |
| TPME158*004#0018 | E | 1500 | 4 | 40 | 6 | 18 | 3 | 3.873 | 3.486 | 1.549 | 0.070 | 0.063 | 0.028 |
| 6.3 Volt @ 85°C (4 Volt @ 125°C) | | | | | | | | | | | | | |
| TPMY227M006#0030 | Y | 220 | 6.3 | 13.2 | 6 | 30 | 3 | 2.646 | 2.381 | 1.058 | 0.079 | 0.071 | 0.032 |
| TPMD337*006#0025 | D | 330 | 6.3 | 19.8 | 8 | 25 | 3 | 3.194 | 2.874 | 1.277 | 0.080 | 0.072 | 0.032 |
| TPMD337*006#0035 | D | 330 | 6.3 | 19.8 | 8 | 35 | 3 | 2.699 | 2.429 | 1.080 | 0.094 | 0.085 | 0.038 |
| TPMD477*006#0030 | D | 470 | 6.3 | 28.2 | 8 | 30 | 3 | 2.915 | 2.624 | 1.166 | 0.087 | 0.079 | 0.035 |
| TPME477*006#0018 | E | 470 | 6.3 | 28 | 6 | 18 | 3 | 3.873 | 3.486 | 1.549 | 0.070 | 0.063 | 0.028 |
| TPME477*006#0023 | E | 470 | 6.3 | 28 | 6 | 23 | 3 | 3.426 | 3.084 | 1.370 | 0.079 | 0.071 | 0.032 |
| TPME477*006#0030 | E | 470 | 6.3 | 28 | 6 | 30 | 3 | 3.000 | 2.700 | 1.200 | 0.090 | 0.081 | 0.036 |
| TPME687*006#0018 | E | 680 | 6.3 | 41 | 6 | 18 | 3 | 3.873 | 3.486 | 1.549 | 0.070 | 0.063 | 0.028 |
| TPME687*006#0023 | E | 680 | 6.3 | 41 | 6 | 23 | 3 | 3.426 | 3.084 | 1.370 | 0.079 | 0.071 | 0.032 |
| TPMV687*006#0023 | V | 680 | 6.3 | 41 | 6 | 23 | 3 | 3.520 | 3.168 | 1.408 | 0.081 | 0.073 | 0.032 |
| TPME108M006#0025 | E | 1000 | 6.3 | 63 | 8 | 25 | 3 | 3.286 | 2.958 | 1.315 | 0.082 | 0.074 | 0.033 |
| TPMV108M006#0020 | V | 1000 | 6.3 | 63 | 8 | 20 | 3 | 3.775 | 3.397 | 1.510 | 0.075 | 0.068 | 0.030 |
| 10 Volt @ 85°C (7 Volt @ 125°C) | | | | | | | | | | | | | |
| TPMY107M010#0045 | Y | 100 | 10 | 10 | 8 | 45 | 3 | 2.160 | 1.944 | 0.864 | 0.097 | 0.087 | 0.039 |
| TPMY157M010#0045 | Y | 150 | 10 | 15 | 8 | 45 | 3 | 2.160 | 1.944 | 0.864 | 0.097 | 0.087 | 0.039 |
| TPMD227*010#0035 | D | 220 | 10 | 22 | 8 | 35 | 3 | 2.699 | 2.429 | 1.080 | 0.094 | 0.085 | 0.038 |
| TPMD337*010#0035 | D | 330 | 10 | 33 | 8 | 35 | 3 | 2.699 | 2.429 | 1.080 | 0.094 | 0.085 | 0.038 |
| TPME337*010#0023 | E | 330 | 10 | 33 | 6 | 23 | 3 | 3.426 | 3.084 | 1.370 | 0.079 | 0.071 | 0.032 |
| TPME337*010#0035 | E | 330 | 10 | 33 | 6 | 35 | 3 | 2.777 | 2.500 | 1.111 | 0.097 | 0.087 | 0.039 |
| TPME477*010#0023 | E | 470 | 10 | 47 | 6 | 23 | 3 | 3.426 | 3.084 | 1.370 | 0.079 | 0.071 | 0.032 |
| TPME477*010#0030 | E | 470 | 10 | 47 | 6 | 30 | 3 | 3.000 | 2.700 | 1.200 | 0.090 | 0.081 | 0.036 |
| 16 Volt @ 85°C (10 Volt @ 125°C) | | | | | | | | | | | | | |
| TPMD686*016#0040 | D | 68 | 16 | 10.9 | 8 | 40 | 3 | 2.525 | 2.272 | 1.010 | 0.101 | 0.091 | 0.040 |
| TPMD686*016#0050 | D | 68 | 16 | 10.9 | 8 | 50 | 3 | 2.258 | 2.032 | 0.903 | 0.113 | 0.102 | 0.045 |
| TPMD107*016#0040 | D | 100 | 16 | 16 | 8 | 40 | 3 | 2.525 | 2.272 | 1.010 | 0.101 | 0.091 | 0.040 |
| TPMD107*016#0050 | D | 100 | 16 | 16 | 8 | 50 | 3 | 2.258 | 2.032 | 0.903 | 0.113 | 0.102 | 0.045 |
| TPME157*016#0030 | E | 150 | 16 | 24 | 6 | 30 | 3 | 3.000 | 2.700 | 1.200 | 0.090 | 0.081 | 0.036 |
| TPME157*016#0040 | E | 150 | 16 | 24 | 6 | 40 | 3 | 2.598 | 2.338 | 1.039 | 0.104 | 0.094 | 0.042 |
| TPME227*016#0025 | E | 220 | 16 | 35 | 6 | 25 | 3 | 3.286 | 2.958 | 1.315 | 0.082 | 0.074 | 0.033 |
| TPME227*016#0040 | E | 220 | 16 | 35 | 6 | 40 | 3 | 2.598 | 2.338 | 1.039 | 0.104 | 0.094 | 0.042 |
| TPME337*016#0050 | E | 330 | 16 | 52.8 | 10 | 50 | 3 | 2.324 | 2.091 | 0.930 | 0.116 | 0.105 | 0.046 |
| 20 Volt @ 85°C (13 Volt @ 125°C) | | | | | | | | | | | | | |
| TPMD476*020#0045 | D | 47 | 20 | 9.4 | 8 | 45 | 3 | 2.380 | 2.142 | 0.952 | 0.107 | 0.096 | 0.043 |
| TPMD476*020#0055 | D | 47 | 20 | 9.4 | 8 | 55 | 3 | 2.153 | 1.938 | 0.861 | 0.118 | 0.107 | 0.047 |
| TPME107*020#0035 | E | 100 | 20 | 20 | 6 | 35 | 3 | 2.777 | 2.500 | 1.111 | 0.097 | 0.087 | 0.039 |
| TPME107*020#0045 | E | 100 | 20 | 20 | 6 | 45 | 3 | 2.449 | 2.205 | 0.980 | 0.110 | 0.099 | 0.044 |
| TPME157*020#0035 | E | 150 | 20 | 30 | 10 | 35 | 3 | 2.777 | 2.500 | 1.111 | 0.097 | 0.087 | 0.039 |
| 25 Volt @ 85°C (17 Volt @ 125°C) | | | | | | | | | | | | | |
| TPMD336*025#0065 | D | 33 | 25 | 8.3 | 8 | 65 | 3 | 1.981 | 1.783 | 0.792 | 0.129 | 0.116 | 0.051 |
| TPMD476*025#0055 | D | 47 | 25 | 11.8 | 8 | 55 | 3 | 2.153 | 1.938 | 0.861 | 0.118 | 0.107 | 0.047 |
| TPME476*025#0065 | E | 47 | 25 | 11.8 | 6 | 65 | 3 | 2.038 | 1.834 | 0.815 | 0.132 | 0.119 | 0.053 |
| TPME686*025#0045 | E | 68 | 25 | 17 | 6 | 45 | 3 | 2.449 | 2.205 | 0.980 | 0.110 | 0.099 | 0.044 |
| TPME686*025#0055 | E | 68 | 25 | 17 | 6 | 55 | 3 | 2.216 | 1.994 | 0.886 | 0.122 | 0.110 | 0.049 |
| 35 Volt @ 85°C (23 Volt @ 125°C) | | | | | | | | | | | | | |
| TPMD226*035#0070 | D | 22 | 35 | 7.7 | 8 | 70 | 3 | 1.909 | 1.718 | 0.763 | 0.134 | 0.120 | 0.053 |
| TPME226*035#0060 | E | 22 | 35 | 8 | 6 | 60 | 3 | 2.121 | 1.909 | 0.849 | 0.127 | 0.115 | 0.051 |
| TPME226*035#0100 | E | 22 | 35 | 8 | 6 | 100 | 3 | 1.643 | 1.479 | 0.657 | 0.164 | 0.148 | 0.066 |
| TPME336*035#0050 | E | 33 | 35 | 12 | 6 | 50 | 3 | 2.324 | 2.091 | 0.930 | 0.116 | 0.105 | 0.046 |
| TPME336*035#0065 | E | 33 | 35 | 12 | 6 | 65 | 3 | 2.038 | 1.834 | 0.815 | 0.132 | 0.119 | 0.053 |
| TPME476*035#0055 | E | 47 | 35 | 16 | 6 | 55 | 3 | 2.216 | 1.994 | 0.886 | 0.122 | 0.110 | 0.049 |
| TPME476*035#0065 | E | 47 | 35 | 16 | 6 | 65 | 3 | 2.038 | 1.834 | 0.815 | 0.132 | 0.119 | 0.053 |
| 50 Volt @ 85°C (33 Volt @ 125°C) | | | | | | | | | | | | | |
| TPMD106*050#0140 | D | 10 | 50 | 5 | 8 | 140 | 3 | 1.350 | 1.215 | 0.540 | 0.189 | 0.170 | 0.076 |
| TPME106*050#0120 | E | 10 | 50 | 5 | 6 | 120 | 3 | 1.500 | 1.350 | 0.600 | 0.180 | 0.162 | 0.072 |
| TPME156*050#0075 | E | 15 | 50 | 7.5 | 6 | 75 | 3 | 1.897 | 1.708 | 0.759 | 0.142 | 0.128 | 0.057 |
| TPME156*050#0100 | E | 15 | 50 | 7.5 | 6 | 100 | 3 | 1.643 | 1.479 | 0.657 | 0.164 | 0.148 | 0.066 |
| TPME226*050#0075 | E | 22 | 50 | 11 | 8 | 75 | 3 | 1.897 | 1.708 | 0.759 | 0.142 | 0.128 | 0.057 |
| TPME226*050#0100 | E | 22 | 50 | 11 | 8 | 100 | 3 | 1.643 | 1.479 | 0.657 | 0.164 | 0.148 | 0.066 |

Moisture Sensitivity Level (MSL) is defined according to J-STD-020.
 All technical data relates to an ambient temperature of +25°C. Capacitance and DF are measured at 120Hz, 0.5V RMS with a maximum DC bias of 2.2 volts.
 DCL is measured at rated voltage after 5 minutes.

The EIA & CECC standards for low ESR Solid Tantalum Capacitors allow an ESR movement to 1.25 times catalogue limit post mounting.

For typical weight and composition see page 144.

NOTE: AVX reserves the right to supply a higher voltage rating or tighter tolerance part in the same case size, to the same reliability standards.



TPC Series



Low ESR TACmicrochip®

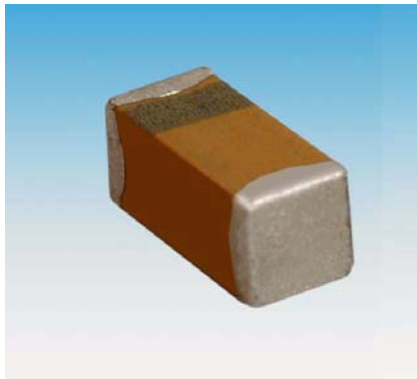

- Low ESR TACmicrochip® capacitor
- Smallest and low profile tantalum
- CV range: 1.0-100µF / 3-25V
- 4 case sizes available
- Power supply applications



CASE DIMENSIONS: millimeters (inches)

| Code | EIA Code | EIA Metric | L+0.20 (0.008) -0.00 (0.000) | W+0.15 (0.008) -0.00 (0.000) | H+0.15 (0.008) -0.00 (0.000) | Termination Spacing(S) | Minimum Termination Length (Lt) |
|------|----------|------------|---------------------------------|--|--|------------------------|---------------------------------|
| H | 0805 | 2012-10 | 2.00 (0.079) | 1.35 (0.053) | 1.00 (0.039) max | 0.70 (0.028) min | 0.15 (0.006) |
| K | 0402 | 1005-07 | 1.00 (0.039) | 0.50 ^{+0.20} _{-0.00} (0.020 -0.000) +0.008 | 0.50 ^{+0.20} _{-0.00} (0.020 -0.000) +0.008 | 0.40 (0.016) min | 0.10 (0.004) |
| L | 0603 | 1608-10 | 1.60 (0.063) | 0.85 (0.033) | 0.85 (0.033) | 0.55 (0.022) min | 0.15 (0.006) |
| R | 0805 | 2012-15 | 2.00 (0.079) | 1.35 (0.053) | 1.35 (0.053) | 0.70 (0.028) min | 0.15 (0.006) |

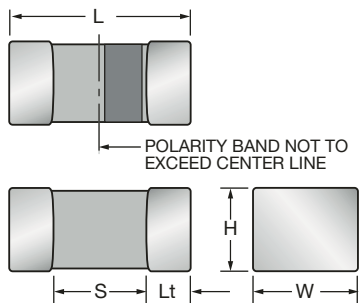

HOW TO ORDER

| | | | | | | |
|------------------------------|-------------------------------------|---|--------------------------------------|---|--|------------------|
| TPC | R | 106 | M | 010 | R | 1800 |
| Type TACmicrochip® | Case Size See table above | Capacitance Code pF code: 1st two digits represent significant figures, 3rd digit represents multiplier (number of zeros to follow) | Tolerance K=±10% M=±20% | Rated DC Voltage 003=3Vdc 004=4Vdc 006=6.3Vdc 010=10Vdc 016=16Vdc 020=20Vdc 025=25Vdc | Packaging R, P = 7" Standard Tin Termination Plastic Tape X, Q = 4 1/4" Standard Tin Termination Plastic Tape A, M = 7" Gold Termination Plastic Tape F, N = 4 1/4" Gold Termination Plastic Tape | ESR in mΩ |

TECHNICAL SPECIFICATIONS

| | | | | | | | | |
|------------------------------------|--|-----|-----|-----|----|----|----|----|
| Technical Data: | All technical data relate to an ambient temperature of +25°C | | | | | | | |
| Capacitance Range: | 1.0 µF to 100 µF | | | | | | | |
| Capacitance Tolerance: | ±10%; ±20% | | | | | | | |
| Leakage Current DCL: | 0.01CV or 0.5µA whichever is the greater | | | | | | | |
| Rated Voltage (V _R) | ≤ +85°C: | 3 | 4 | 6.3 | 10 | 16 | 20 | 25 |
| Category Voltage (V _C) | ≤ +125°C: | 2 | 2.7 | 4 | 7 | 10 | 13 | 17 |
| Surge Voltage (V _S) | ≤ +85°C: | 3.9 | 5.2 | 8 | 13 | 20 | 26 | 32 |
| Surge Voltage (V _S) | ≤ +125°C: | 2.6 | 3.2 | 5 | 8 | 12 | 16 | 20 |
| Temperature Range: | -55°C to +125°C | | | | | | | |
| Reliability: | 1% per 1000 hours at 85°C, V _R with 0.1Ω/V series impedance, 60% confidence level | | | | | | | |
| Termination Finish: | Nickel and Tin Plating (standard), Nickel and Gold Plating option available upon request | | | | | | | |

TPC Series



Low ESR TACmicrochip®

LOW ESR RANGE (LETTER DENOTES CASE SIZE)

| Capacitance | | Voltage Rating DC (V _R) at 85°C | | | | | | |
|-------------|------|---|---------------------------------|------------------------|--|---------|-------------------------|---------|
| µF | Code | 3.0V | 4.0V | 6.3V | 10V | 16V | 20V | 25V |
| 1.0 | 105 | | | | L(5000) | | | R(3000) |
| 1.5 | 155 | | | | | | | |
| 2.2 | 225 | | | K(8000)/L(5000) | L(5000) | L(5000) | | |
| 3.3 | 335 | | | | L(5000) | | | |
| 4.7 | 475 | K(8000) | | | L(5000) ^(M) | | R(1500) ^{(M)*} | |
| 6.8 | 685 | | | | | | | |
| 10 | 106 | | | L(4000) ^(M) | H(2500) L(4000) ^(M) ,R(1800) | R(1800) | | |
| 15 | 156 | | | R(1800) | R(1500) | | | |
| 22 | 226 | | L(5000) ^(M) /R(1800) | R(1500) | R(1500) | | | |
| 33 | 336 | R(1800) | H(1500) ^(M) /R(1500) | | R(1500) ^(M) | | | |
| 47 | 476 | R(1500) | | R(1800) ^(M) | | | | |
| 68 | 686 | | | | | | | |
| 100 | 107 | | R(1000) ^(M) | | | | | |

Codes shown are examples of ESR values offered on certain CV and case size. Other codes and ESR values available upon request.

Released codes ^(M tolerance only)

*Code under development – subject to change

Note: Voltage ratings are minimum values. AVX reserves the right to supply higher ratings in the same case size, to the same reliability standards

RATINGS & PART NUMBER REFERENCE

| AVX Part No. | EIA | Case Size | Cap (µF) | Rated Voltage (V) | DCL (µA) Max. | DF % Max. | ESR Max. (mΩ) @100kHz | MSL | 100kHz Ripple Current Ratings (A) | | | 100kHz Ripple Voltage Ratings (V) | | |
|---|------|-----------|----------|-------------------|---------------|-----------|-----------------------|-----|-----------------------------------|-------|-------|-----------------------------------|-------|-------|
| | | | | | | | | | 25°C | 85°C | 125°C | 25°C | 85°C | 125°C |
| 3 Volt @ 85°C (2 Volt @ 125°C) | | | | | | | | | | | | | | |
| TPCK475*003#8000 | 0402 | K | 4.7 | 3 | 0.5 | 12 | 8000 | 1 | 0.043 | 0.039 | 0.017 | 0.346 | 0.312 | 0.139 |
| TPCR336*003#1800 | 0805 | R | 33 | 3 | 1.0 | 10 | 1800 | 1 | 0.158 | 0.142 | 0.063 | 0.285 | 0.256 | 0.114 |
| TPCR476*003#1500 | 0805 | R | 47 | 3 | 1.5 | 10 | 1500 | 1 | 0.173 | 0.156 | 0.069 | 0.260 | 0.234 | 0.104 |
| 4 Volt @ 85°C (2.7 Volt @ 125°C) | | | | | | | | | | | | | | |
| TPCL226M004#5000 | 0603 | L | 22 | 4 | 0.9 | 6 | 5000 | 1 | 0.071 | 0.064 | 0.028 | 0.354 | 0.318 | 0.141 |
| TPCR226*004#1800 | 0805 | R | 22 | 4 | 0.9 | 8 | 1800 | 1 | 0.158 | 0.142 | 0.063 | 0.285 | 0.256 | 0.114 |
| TPCH336M004#1500 | 0805 | H | 33 | 4 | 1.3 | 14 | 1500 | 1 | 0.163 | 0.147 | 0.065 | 0.245 | 0.221 | 0.098 |
| TPCR336*004#1500 | 0805 | R | 33 | 4 | 1.3 | 10 | 1500 | 1 | 0.173 | 0.156 | 0.069 | 0.260 | 0.234 | 0.104 |
| TPCR107M004#1000 | 0805 | R | 100 | 4 | 4.0 | 30 | 1000 | 1 | 0.212 | 0.191 | 0.085 | 0.212 | 0.191 | 0.085 |
| 6.3 Volt @ 85°C (4 Volt @ 125°C) | | | | | | | | | | | | | | |
| TPCK225*006#8000 | 0402 | K | 2.2 | 6.3 | 0.5 | 8 | 8000 | 1 | 0.043 | 0.039 | 0.017 | 0.346 | 0.312 | 0.139 |
| TPCL225*006#5000 | 0603 | L | 2.2 | 6.3 | 0.5 | 6 | 5000 | 1 | 0.071 | 0.064 | 0.028 | 0.354 | 0.318 | 0.141 |
| TPCL106M006#4000 | 0603 | L | 10 | 6.3 | 0.6 | 10 | 4000 | 1 | 0.079 | 0.071 | 0.032 | 0.316 | 0.285 | 0.126 |
| TPCR156*006#1800 | 0805 | R | 15 | 6.3 | 0.9 | 8 | 1800 | 1 | 0.158 | 0.142 | 0.063 | 0.285 | 0.256 | 0.114 |
| TPCR226*006#1500 | 0805 | R | 22 | 6.3 | 1.4 | 10 | 1500 | 1 | 0.173 | 0.156 | 0.069 | 0.260 | 0.234 | 0.104 |
| TPCR476M006#1800 | 0805 | R | 47 | 6.3 | 3.0 | 20 | 1800 | 1 | 0.158 | 0.142 | 0.063 | 0.285 | 0.256 | 0.114 |
| 10 Volt @ 85°C (7 Volt @ 125°C) | | | | | | | | | | | | | | |
| TPCL105*010#5000 | 0603 | L | 1.0 | 10 | 0.5 | 6 | 5000 | 1 | 0.071 | 0.064 | 0.028 | 0.354 | 0.318 | 0.141 |
| TPCL225*010#5000 | 0603 | L | 2.2 | 10 | 0.5 | 6 | 5000 | 1 | 0.071 | 0.064 | 0.028 | 0.354 | 0.318 | 0.141 |
| TPCL335*010#5000 | 0603 | L | 3.3 | 10 | 0.5 | 8 | 5000 | 1 | 0.071 | 0.064 | 0.028 | 0.354 | 0.318 | 0.141 |
| TPCL475M010#5000 | 0603 | L | 4.7 | 10 | 0.5 | 10 | 5000 | 1 | 0.071 | 0.064 | 0.028 | 0.354 | 0.318 | 0.141 |
| TPCH106*010#2500 | 0805 | H | 10 | 10 | 1.0 | 8 | 2500 | 1 | 0.126 | 0.113 | 0.050 | 0.100 | 0.09 | 0.040 |
| TPCL106M010#4000 | 0603 | L | 10 | 10 | 1.0 | 20 | 4000 | 1 | 0.079 | 0.071 | 0.032 | 0.316 | 0.285 | 0.126 |
| TPCR106*010#1800 | 0805 | R | 10 | 10 | 1.0 | 8 | 1800 | 1 | 0.158 | 0.142 | 0.063 | 0.285 | 0.256 | 0.114 |
| TPCR156*010#1500 | 0805 | R | 15 | 10 | 1.5 | 10 | 1500 | 1 | 0.173 | 0.156 | 0.069 | 0.260 | 0.234 | 0.104 |
| TPCR226*010#1500 | 0805 | R | 22 | 10 | 2.2 | 14 | 1500 | 1 | 0.173 | 0.156 | 0.069 | 0.260 | 0.234 | 0.104 |
| TPCR336M010#1500 | 0805 | R | 33 | 10 | 3.3 | 20 | 1500 | 1 | 0.173 | 0.156 | 0.069 | 0.260 | 0.234 | 0.104 |
| 16 Volt @ 85°C (10 Volt @ 125°C) | | | | | | | | | | | | | | |
| TPCL225*016#5000 | 0603 | L | 2.2 | 16 | 0.5 | 10 | 5000 | 1 | 0.071 | 0.064 | 0.028 | 0.354 | 0.318 | 0.141 |
| TPCR106*016#1800 | 0805 | R | 10 | 16 | 1.6 | 10 | 1800 | 1 | 0.158 | 0.142 | 0.063 | 0.285 | 0.256 | 0.114 |
| 20 Volt @ 85°C (13 Volt @ 125°C) | | | | | | | | | | | | | | |
| TPCR475M020#1500 | 0805 | R | 4.7 | 20 | 0.9 | 8 | 1500 | 1 | 0.173 | 0.156 | 0.069 | 0.260 | 0.234 | 0.104 |
| 25 Volt @ 85°C (17 Volt @ 125°C) | | | | | | | | | | | | | | |
| TPCR105*025#3000 | 0805 | R | 1.0 | 25 | 0.5 | 8 | 3000 | 1 | 0.122 | 0.110 | 0.049 | 0.367 | 0.331 | 0.147 |

Moisture Sensitivity Level (MSL) is defined according to J-STD-020.

All technical data relates to an ambient temperature of +25°C. Capacitance and DF are measured at 120Hz, 0.5V RMS with a maximum DC bias of 2.2 volts. DCL is measured at rated voltage after 5 minutes.

The EIA & CECC standards for low ESR Solid Tantalum Capacitors allow an ESR movement to 1.25 times catalogue limit post mounting.

For typical weight and composition see page 144.

NOTE: AVX reserves the right to supply a higher voltage rating or tighter tolerance part in the same case size, to the same reliability standards.

TCJ Series



Tantalum Solid Electrolytic Chip Capacitors with Conductive Polymer Electrode



- Conductive polymer electrode reduces ignition failure mode
- Lower ESR
- 3x reflow 260°C compatible
- CV range: 0.47-470µF / 2.5-125V
- 16 case sizes available



Elektra Award 2010



LEAD-FREE
LEAD-FREE COMPATIBLE COMPONENT



RoHS
COMPLIANT

CASE DIMENSIONS: millimeters (inches)

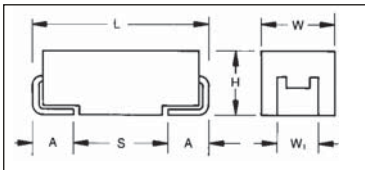

For part marking see page 151

| Code | EIA Code | EIA Metric | L±0.20 (0.008) | W+0.20 (0.008) -0.10 (0.004) | H+0.20 (0.008) -0.10 (0.004) | W ₁ ±0.20 (0.008) | A+0.30 (0.012) -0.20 (0.008) | S Min. |
|------|----------|------------|----------------|------------------------------|------------------------------|------------------------------|------------------------------|--------------|
| A | 1206 | 3216-18 | 3.20 (0.126) | 1.60 (0.063) | 1.60 (0.063) | 1.20 (0.047) | 0.80 (0.031) | 1.10 (0.043) |
| B | 1210 | 3528-21 | 3.50 (0.138) | 2.80 (0.110) | 1.90 (0.075) | 2.20 (0.087) | 0.80 (0.031) | 1.40 (0.055) |
| C | 2312 | 6032-28 | 6.00 (0.236) | 3.20 (0.126) | 2.60 (0.102) | 2.20 (0.087) | 1.30 (0.051) | 2.90 (0.114) |
| D | 2917 | 7343-31 | 7.30 (0.287) | 4.30 (0.169) | 2.90 (0.114) | 2.40 (0.094) | 1.30 (0.051) | 4.40 (0.173) |
| E | 2917 | 7343-43 | 7.30 (0.287) | 4.30 (0.169) | 4.10 (0.162) | 2.40 (0.094) | 1.30 (0.051) | 4.40 (0.173) |
| G | 1206 | 3216-15 | 3.20 (0.126) | 1.60 (0.063) | 1.50 (0.059) max | 1.20 (0.047) | 0.80 (0.031) | 1.10 (0.043) |
| H | 1210 | 3528-15 | 3.50 (0.138) | 2.80 (0.110) | 1.50 (0.059) max | 2.20 (0.087) | 0.80 (0.031) | 1.40 (0.055) |
| K | 1206 | 3216-10 | 3.20 (0.126) | 1.60 (0.063) | 1.00 (0.039) max | 1.20 (0.047) | 0.80 (0.031) | 1.10 (0.043) |
| N | 0805 | 2012-10 | 2.05 (0.081) | 1.30 (0.051) | 1.00 (0.039) max | 1.00 (0.039) | 0.50 (0.020) | 0.85 (0.033) |
| P | 0805 | 2012-15 | 2.05 (0.081) | 1.35 (0.050) | 1.50 (0.059) max | 1.00±0.10 (0.039±0.004) | 0.50 (0.020) | 0.85 (0.033) |
| R | 0805 | 2012-12 | 2.05 (0.081) | 1.30 (0.051) | 1.20 (0.047) max | 1.00±0.10 (0.039±0.004) | 0.50 (0.020) | 0.85 (0.033) |
| S | 1206 | 3216-12 | 3.20 (0.126) | 1.60 (0.063) | 1.20 (0.047) max | 1.20 (0.047) | 0.80 (0.031) | 1.10 (0.043) |
| T | 1210 | 3528-12 | 3.50 (0.138) | 2.80 (0.110) | 1.20 (0.047) max | 2.20 (0.087) | 0.80 (0.031) | 1.40 (0.055) |
| V | 2924 | 7361-38 | 7.30 (0.287) | 6.10 (0.240) | 3.55 (0.140) | 3.10 (0.120) | 1.30 (0.051) | 4.40 (0.173) |
| W | 2312 | 6032-15 | 6.00 (0.236) | 3.20 (0.126) | 1.50 (0.059) max | 2.20 (0.087) | 1.30 (0.051) | 2.90 (0.114) |
| Y | 2917 | 7343-20 | 7.30 (0.287) | 4.30 (0.169) | 2.00 (0.079) max | 2.40 (0.094) | 1.30 (0.051) | 4.40 (0.173) |

W1 dimension applies to the termination width for A dimensional area only.

HOW TO ORDER

TCJ

Type

A

Case Size
See table above

226

Capacitance Code
pF code: 1st two digits represent significant figures, 3rd digit represents multiplier (number of zeros to follow)

M

Tolerance
M=±20%

004

Rated DC Voltage
002=2.5Vdc
004=4Vdc
006=6.3Vdc
010=10Vdc
016=16Vdc
020=20Vdc
025=25Vdc
035=35Vdc
050=50Vdc
063=63Vdc
075=75Vdc
100=100Vdc
125=125Vdc

R

Packaging
R = Pure Tin 7" Reel
S = Pure Tin 13" Reel

0300

ESR in mΩ

TECHNICAL SPECIFICATIONS

Technical Data:

All technical data relate to an ambient temperature of +25°C

Capacitance Range: 0.47 µF to 470 µF

Capacitance Tolerance: ±20%

Leakage Current DCL: 0.1CV

| Rated Voltage (V _R) | ≤ +85°C: | 2.5 | 4 | 6.3 | 10 | 16 | 2.5 | 4 | 6.3 | 10 | 16 | 20 | 25 | 35 | 50 | 63 | 75 | 100 | 125 |
|------------------------------------|-----------|-----|-----|-----|----|----|------|-----|-----|----|------|----|----|----|----|------|------|-----|-------|
| Category Voltage (V _C) | ≤ +105°C: | | | | | | 2 | 3.2 | 5 | 8 | 12.8 | 16 | 20 | 28 | 40 | 50.4 | 60 | 80 | 100 |
| Category Voltage (V _C) | ≤ +125°C: | 1.7 | 2.7 | 4 | 7 | 10 | | | | | | | | | | | | | |
| Surge Voltage (V _S) | ≤ +85°C: | 3.3 | 5.2 | 8 | 13 | 20 | 3.25 | 5.2 | 8 | 13 | 20.8 | 26 | 33 | 46 | 65 | 81.9 | 97.5 | 130 | 162.5 |
| Surge Voltage (V _S) | ≤ +105°C: | | | | | | 2.5 | 4 | 6 | 10 | 16 | 20 | 25 | 35 | 50 | 63 | 75 | 100 | 125 |
| Surge Voltage (V _S) | ≤ +125°C: | 2.2 | 3.4 | 5 | 8 | 13 | | | | | | | | | | | | | |

Temperature Range: -55°C to +125°C, -55°C to +105°C

Reliability: 1% per 1000 hours at 85°C, V_R with 0.1Ω/V series impedance, 60% confidence level



TCJ Series



Tantalum Solid Electrolytic Chip Capacitors with Conductive Polymer Electrode

CAPACITANCE AND RATED VOLTAGE, VR (VOLTAGE CODE) RANGE (LETTER DENOTES CASE SIZE)

125°C RATED PARTS

| Capacitance | | Rated Voltage DC (V _R) to 85°C | | | | |
|-------------|------|--|---------------------------------|--|----------------------------------|----------------------------|
| µF | Code | 2.5V (e) | 4V (G) | 6.3V (J) | 10V (A) | 16V (C) |
| 1.0 | 105 | | | | | |
| 4.7 | 475 | | | | K(500), R(500) | |
| 6.8 | 685 | | | | | A(200) |
| 10 | 106 | | | A(300), R(500) | A(300) | A(200), B(200), T(150,200) |
| 15 | 156 | | A(300) | A(300) | A(200) | B(150) |
| 22 | 226 | | A(300) | A(300), K(400) R(500), S(400), T(150) | B(300), T(150) | B(150) |
| 33 | 336 | | A(300) | A(200) B(70,200) T(150) | B(70,200) C(100) T(70,150) | |
| 47 | 476 | | A(200), T(80) | A(200), B(70) K(400), P(500) T(80,120) | B(70), C(100) | |
| 68 | 686 | A(250) | A(250), B(70) T(80) | B(55,70) C(100), W(70) | | |
| 100 | 107 | A(200), B(70) | A(200), B(70) G(300), T(150) | B(45,69,70) | | |
| 150 | 157 | B(70) | B(70) | B(45,69,70) H(200), W(40,70) | | |
| 220 | 227 | | B(45,70) | B(70,200) | | |

105°C RATED PARTS

| Cap | | Rated Voltage DC (V _R) to 85°C | | | | | | | | | | | | |
|------|------|--|-----------------|------------------------------|--------------------|----------------------|---------------|-------------------------------------|-----------------------------------|----------------------|-----------------------|---------|----------|----------|
| µF | Code | 2.5V (e) | 4V (G) | 6.3V (J) | 10V (A) | 16V (C) | 20V (D) | 25V (E) | 35V (V) | 50V (T) | 63V (J) | 75V (P) | 100V (A) | 125V (B) |
| 0.47 | 474 | | | | | | | | | | B(400) | | | |
| 0.68 | 684 | | | | | | | | | B(400) | B(300) | | | |
| 1.0 | 105 | | | | | | | N*, P(500) | A(250)* | A*, B(300) | B(300), C(300) | | | |
| 1.5 | 155 | | | | | | | | B(200) | B(300), C(300) | C(300) | | | |
| 2.2 | 225 | | | | | | | | B(200) | C(300) | C(200) | | | |
| 3.3 | 335 | | | | | | | | B(200) | C(200) | C(200) | | | D(250) |
| 4.7 | 475 | | | | | | | B(150) | B(200), C(200) | C(200) | C(200), D(120) | D(150) | | |
| 6.8 | 685 | | | | | | | B(150) | C(200) | C(200), D(120) | D(120), E(100,150) | D(120) | V(250) | |
| 10 | 106 | | | N(200*,500) | | | | B(150) | B(200), C(200), Y(70) | D(120), E(70,100) | E(100,150) | | | |
| 15 | 156 | | | | | | | B(100,150), Y(70,200)* | C(200), D(70,100), W*, Y(200)* | E(70,100) | | | | |
| 22 | 226 | | | N(500) | | | Y(70) | B(150), C(100), D(60,100), Y(70) | D(70,100), Y(70)* | | | | | |
| 33 | 336 | | | | | Y(60,70) | Y(70) | D(60,100), Y(70,100) | D(70,100), E(55,70) | | | | | |
| 47 | 476 | | | K(150,200), R(500), T(70) | | Y(45,70) | D(55)*, Y(70) | D(60,100), E(50) | E(55) | | | | | |
| 68 | 686 | | | T(200) | | D(45,55) Y(45,55) | D(55), E(45) | E(50) | | | | | | |
| 100 | 107 | | | A(70)*, T(200) | D(45,55), Y(45,55) | E(40) | D(55), E(45) | E(80) | | | | | | |
| 150 | 157 | | | B(35), Y(40) | D(45,55), Y(45,55) | E(40) | | | | | | | | |
| 220 | 227 | A(35)* | B(60) | D(40,50) W(100)*, Y(50) | D(40,50), Y(40,50) | | | | | | | | | |
| 330 | 337 | | D(50), Y(50) | D(40,50) Y(40,50) | | | | | | | | | | |
| 470 | 477 | D(50), Y(50) | D(50) Y(50) | | | | | | | | | | | |

Available Ratings, (ESR ratings in mOhms in brackets)

Engineering samples - please contact manufacturer

*Codes under development - subject to change

Note: Voltage ratings are minimum values. AVX reserves the right to supply higher ratings in the same case size, to the same reliability standards.



TCJ Series



Tantalum Solid Electrolytic Chip Capacitors with Conductive Polymer Electrode

RATINGS & PART NUMBER REFERENCE

| AVX Part No. | Case Size | Capacitance (μF) | Rated Voltage (V) | DCL (μA) Max. | DF % Max. | ESR Max. (mΩ) @100kHz | MSL | 100kHz RMS Current (mA) | | | 100kHz RMS Voltage (mV) | | |
|---|-----------|------------------|-------------------|---------------|-----------|-----------------------|-----|-------------------------|------|-------|-------------------------|------|-------|
| | | | | | | | | 25°C | 85°C | 125°C | 25°C | 85°C | 125°C |
| 2.5 Volt @ 85°C (1.7 Volt @ 125°C) | | | | | | | | | | | | | |
| TCJA686M002#0250 | A | 68 | 2.5 | 17.0 | 6 | 250 | 3 | 548 | 493 | 219 | 137 | 123 | 55 |
| TCJA107M002#0200 | A | 100 | 2.5 | 25.0 | 6 | 200 | 3 | 612 | 551 | 245 | 122 | 110 | 49 |
| TCJB107M002#0070 | B | 100 | 2.5 | 25.0 | 6 | 70 | 3 | 1102 | 992 | 441 | 77 | 69 | 31 |
| TCJB157M002#0070 | B | 150 | 2.5 | 37.5 | 6 | 70 | 3 | 1102 | 992 | 441 | 77 | 69 | 31 |
| 4 Volt @ 85°C (2.7 Volt @ 125°C) | | | | | | | | | | | | | |
| TCJA156M004#0300 | A | 15 | 4 | 6.0 | 6 | 300 | 3 | 500 | 450 | 200 | 150 | 135 | 60 |
| TCJA226M004#0300 | A | 22 | 4 | 8.8 | 6 | 300 | 3 | 500 | 450 | 200 | 150 | 135 | 60 |
| TCJA336M004#0300 | A | 33 | 4 | 13.2 | 6 | 300 | 3 | 500 | 450 | 200 | 150 | 135 | 60 |
| TCJA476M004#0200 | A | 47 | 4 | 18.8 | 6 | 200 | 3 | 612 | 551 | 245 | 122 | 110 | 49 |
| TCJT476M004#0080 | T | 47 | 4 | 18.8 | 8 | 80 | 3 | 1000 | 900 | 400 | 80 | 72 | 32 |
| TCJA686M004#0250 | A | 68 | 4 | 27.2 | 6 | 250 | 3 | 548 | 493 | 219 | 137 | 123 | 55 |
| TCJB686M004#0070 | B | 68 | 4 | 27.2 | 6 | 70 | 3 | 1102 | 992 | 441 | 77 | 69 | 31 |
| TCJT686M004#0080 | T | 68 | 4 | 27.2 | 8 | 80 | 3 | 1000 | 900 | 400 | 80 | 72 | 32 |
| TCJA107M004#0200 | A | 100 | 4 | 40.0 | 6 | 200 | 3 | 612 | 551 | 245 | 122 | 110 | 49 |
| TCJB107M004#0070 | B | 100 | 4 | 40.0 | 8 | 70 | 3 | 1102 | 992 | 441 | 77 | 69 | 31 |
| TCJG107M004#0300 | G | 100 | 4 | 40.0 | 10 | 300 | 3 | 483 | 435 | 193 | 145 | 130 | 58 |
| TCJT107M004#0150 | T | 100 | 4 | 40.0 | 8 | 150 | 3 | 730 | 657 | 292 | 110 | 99 | 44 |
| TCJB157M004#0070 | B | 150 | 4 | 60.0 | 6 | 70 | 3 | 1102 | 992 | 441 | 77 | 69 | 31 |
| TCJB227M004#0045 | B | 220 | 4 | 88.0 | 10 | 45 | 3 | 1374 | 1237 | 550 | 62 | 56 | 25 |
| TCJB227M004#0070 | B | 220 | 4 | 88.0 | 10 | 70 | 3 | 1102 | 992 | 441 | 77 | 69 | 31 |
| 6.3 Volt @ 85°C (4 Volt @ 125°C) | | | | | | | | | | | | | |
| TCJA106M006#0300 | A | 10 | 6.3 | 6.0 | 6 | 300 | 3 | 500 | 450 | 200 | 150 | 135 | 60 |
| TCJR106M006#0500 | R | 10 | 6.3 | 6.0 | 6 | 500 | 3 | 332 | 298 | 133 | 166 | 149 | 66 |
| TCJA156M006#0300 | A | 15 | 6.3 | 9.0 | 6 | 300 | 3 | 500 | 450 | 200 | 150 | 135 | 60 |
| TCJA226M006#0300 | A | 22 | 6.3 | 13.2 | 6 | 300 | 3 | 500 | 450 | 200 | 150 | 135 | 60 |
| TCJK226M006#0400 | K | 22 | 6.3 | 13.2 | 8 | 400 | 3 | 403 | 363 | 161 | 161 | 145 | 64 |
| TCJR226M006#0500 | R | 22 | 6.3 | 13.2 | 10 | 500 | 3 | 332 | 298 | 133 | 166 | 149 | 66 |
| TCJS226M006#0400 | S | 22 | 6.3 | 13.2 | 8 | 400 | 3 | 403 | 363 | 161 | 161 | 145 | 64 |
| TCJT226M006#0150 | T | 22 | 6.3 | 13.2 | 6 | 150 | 3 | 730 | 657 | 292 | 110 | 99 | 44 |
| TCJA336M006#0200 | A | 33 | 6.3 | 19.8 | 6 | 200 | 3 | 612 | 551 | 245 | 122 | 110 | 49 |
| TCJB336M006#0070 | B | 33 | 6.3 | 19.8 | 6 | 70 | 3 | 1102 | 992 | 441 | 77 | 69 | 31 |
| TCJB336M006#0200 | B | 33 | 6.3 | 19.8 | 6 | 200 | 3 | 652 | 587 | 261 | 130 | 117 | 52 |
| TCJT336M006#0150 | T | 33 | 6.3 | 19.8 | 8 | 150 | 3 | 730 | 657 | 292 | 110 | 99 | 44 |
| TCJA476M006#0200 | A | 47 | 6.3 | 28.2 | 6 | 200 | 3 | 612 | 551 | 245 | 122 | 110 | 49 |
| TCJB476M006#0070 | B | 47 | 6.3 | 28.2 | 6 | 70 | 3 | 1102 | 992 | 441 | 77 | 69 | 31 |
| TCJK476M006#0400 | K | 47 | 6.3 | 28.2 | 6 | 400 | 3 | 403 | 363 | 161 | 161 | 146 | 64 |
| TCJP476M006#0500 | P | 47 | 6.3 | 28.2 | 10 | 500 | 3 | 346 | 312 | 139 | 173 | 156 | 69 |
| TCJT476M006#0080 | T | 47 | 6.3 | 28.2 | 8 | 80 | 3 | 1000 | 900 | 400 | 80 | 72 | 32 |
| TCJT476M006#0120 | T | 47 | 6.3 | 28.2 | 8 | 120 | 3 | 816 | 735 | 327 | 98 | 88 | 39 |
| TCJB686M006#0055 | B | 68 | 6.3 | 40.8 | 8 | 55 | 3 | 1243 | 1119 | 497 | 68 | 62 | 27 |
| TCJB686M006#0070 | B | 68 | 6.3 | 40.8 | 8 | 70 | 3 | 1102 | 992 | 441 | 77 | 69 | 31 |
| TCJC686M006#0100 | C | 68 | 6.3 | 40.8 | 6 | 100 | 3 | 1049 | 944 | 420 | 105 | 94 | 42 |
| TCJW686M006#0070 | W | 68 | 6.3 | 40.8 | 8 | 70 | 3 | 1134 | 1021 | 454 | 79 | 71 | 32 |
| TCJB107M006#0045 | B | 100 | 6.3 | 60.0 | 10 | 45 | 3 | 1374 | 1237 | 550 | 62 | 56 | 25 |
| TCJB107M006#0069 | B | 100 | 6.3 | 60.0 | 10 | 69 | 3 | 1110 | 999 | 444 | 77 | 69 | 31 |
| TCJB107M006#0070 | B | 100 | 6.3 | 60.0 | 10 | 70 | 3 | 1102 | 992 | 441 | 77 | 69 | 31 |
| TCJB157M006#0045 | B | 150 | 6.3 | 90.0 | 10 | 45 | 3 | 1374 | 1237 | 550 | 62 | 56 | 25 |
| TCJB157M006#0069 | B | 150 | 6.3 | 90.0 | 10 | 69 | 3 | 1110 | 999 | 444 | 77 | 69 | 31 |
| TCJB157M006#0070 | B | 150 | 6.3 | 90.0 | 10 | 70 | 3 | 1102 | 992 | 441 | 77 | 69 | 31 |
| TCJH157M006#0200 | H | 150 | 6.3 | 90.0 | 6 | 200 | 3 | 632 | 569 | 253 | 126 | 114 | 51 |
| TCJW157M006#0040 | W | 150 | 6.3 | 90.0 | 6 | 40 | 3 | 1500 | 1350 | 600 | 60 | 54 | 24 |
| TCJW157M006#0070 | W | 150 | 6.3 | 90.0 | 6 | 70 | 3 | 1134 | 1021 | 454 | 79 | 71 | 32 |
| TCJB227M006#0070 | B | 220 | 6.3 | 132.0 | 10 | 70 | 3 | 1102 | 992 | 441 | 77 | 69 | 31 |
| TCJB227M006#0200 | B | 220 | 6.3 | 132.0 | 10 | 200 | 3 | 652 | 587 | 261 | 130 | 117 | 52 |
| 10 Volt @ 85°C (7 Volt @ 125°C) | | | | | | | | | | | | | |
| TCJK475M010#0500 | K | 4.7 | 10 | 4.7 | 6 | 500 | 3 | 361 | 324 | 144 | 180 | 162 | 72 |
| TCJR475M010#0500 | R | 4.7 | 10 | 4.7 | 6 | 500 | 3 | 332 | 298 | 133 | 166 | 149 | 66 |
| TCJA106M010#0300 | A | 10 | 10 | 10.0 | 6 | 300 | 3 | 500 | 450 | 200 | 150 | 135 | 60 |
| TCJA156M010#0200 | A | 15 | 10 | 15.0 | 6 | 200 | 3 | 612 | 551 | 245 | 122 | 110 | 49 |

Moisture Sensitivity Level (MSL) is defined according to J-STD-020.

All technical data relates to an ambient temperature of +25°C. Capacitance and DF are measured at 120Hz, 0.5RMS with DC bias of 2.2 volts. DCL is measured at rated voltage after 5 minutes.

ESR allowed to move up to 1.25 times catalog limit post mounting.

For typical weight and composition see page 144.

NOTE: AVX reserves the right to supply a higher voltage rating or tighter tolerance part in the same case size, to the same reliability standards.



TCJ Series



Tantalum Solid Electrolytic Chip Capacitors with Conductive Polymer Electrode

RATINGS & PART NUMBER REFERENCE

| AVX Part No. | Case Size | Capacitance (µF) | Rated Voltage (V) | DCL (µA) Max. | DF % Max. | ESR Max. (mΩ) @100kHz | MSL | 100kHz RMS Current (mA) | | | 100kHz RMS Voltage (mV) | | |
|---|-----------|------------------|-------------------|---------------|-----------|-----------------------|-----|-------------------------|------|-------|-------------------------|------|-------|
| | | | | | | | | 25°C | 85°C | 125°C | 25°C | 85°C | 125°C |
| TCJB226M010#0300 | B | 22 | 10 | 22.0 | 6 | 300 | 3 | 532 | 479 | 213 | 160 | 144 | 64 |
| TCJT226M010#0150 | T | 22 | 10 | 22.0 | 6 | 150 | 3 | 730 | 657 | 292 | 110 | 99 | 44 |
| TCJB336M010#0070 | B | 33 | 10 | 33.0 | 6 | 70 | 3 | 1102 | 992 | 441 | 77 | 69 | 31 |
| TCJB336M010#0200 | B | 33 | 10 | 33.0 | 6 | 200 | 3 | 652 | 587 | 261 | 130 | 117 | 52 |
| TCJC336M010#0100 | C | 33 | 10 | 33.0 | 6 | 100 | 3 | 1049 | 944 | 420 | 105 | 94 | 42 |
| TCJT336M010#0070 | T | 33 | 10 | 33.0 | 6 | 70 | 3 | 1069 | 962 | 428 | 75 | 67 | 30 |
| TCJT336M010#0150 | T | 33 | 10 | 33.0 | 6 | 150 | 3 | 730 | 657 | 292 | 110 | 99 | 44 |
| TCJB476M010#0070 | B | 47 | 10 | 47.0 | 6 | 70 | 3 | 1102 | 992 | 441 | 77 | 69 | 31 |
| TCJC476M010#0100 | C | 47 | 10 | 47.0 | 6 | 100 | 3 | 1049 | 944 | 420 | 105 | 94 | 42 |
| 16 Volt @ 85°C (10 Volt @ 125°C) | | | | | | | | | | | | | |
| TCJA685M016#0200 | A | 6.8 | 16 | 10.9 | 6 | 200 | 3 | 612 | 551 | 245 | 122 | 110 | 49 |
| TCJA106M016#0200 | A | 10 | 16 | 16.0 | 6 | 200 | 3 | 612 | 551 | 245 | 122 | 110 | 49 |
| TCJB106M016#0200 | B | 10 | 16 | 16.0 | 6 | 200 | 3 | 652 | 587 | 261 | 130 | 117 | 52 |
| TCJT106M016#0150 | T | 10 | 16 | 16.0 | 6 | 150 | 3 | 730 | 657 | 292 | 110 | 99 | 44 |
| TCJT106M016#0200 | T | 10 | 16 | 16.0 | 6 | 200 | 3 | 632 | 569 | 253 | 126 | 114 | 51 |
| TCJB156M016#0150 | B | 15 | 16 | 24.0 | 6 | 150 | 3 | 753 | 677 | 301 | 113 | 102 | 45 |
| TCJB226M016#0150 | B | 22 | 16 | 35.2 | 6 | 150 | 3 | 753 | 677 | 301 | 113 | 102 | 45 |

Moisture Sensitivity Level (MSL) is defined according to J-STD-020.

All technical data relates to an ambient temperature of +25°C. Capacitance and DF are measured at 120Hz, 0.5RMS with DC bias of 2.2 volts. DCL is measured at rated voltage after 5 minutes.

ESR allowed to move up to 1.25 times catalog limit post mounting.

For typical weight and composition see page 144.

NOTE: AVX reserves the right to supply a higher voltage rating or tighter tolerance part in the same case size, to the same reliability standards.

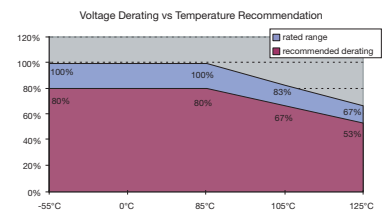

| AVX Part No. | Case Size | Capacitance (µF) | Rated Voltage (V) | DCL (µA) Max. | DF % Max. | ESR Max. (mΩ) @100kHz | MSL | 100kHz RMS Current (mA) | | | 100kHz RMS Voltage (mV) | | |
|---|-----------|------------------|-------------------|---------------|-----------|-----------------------|-----|-------------------------|------|-------|-------------------------|------|-------|
| | | | | | | | | 25°C | 85°C | 105°C | 25°C | 85°C | 105°C |
| 2.5 Volt @ 85°C (2 Volt @ 105°C) | | | | | | | | | | | | | |
| TCJD477M002#0050 | D | 470 | 2.5 | 117.5 | 6 | 50 | 3 | 1732 | 1559 | 1126 | 87 | 78 | 56 |
| TCJY477M002#0050 | Y | 470 | 2.5 | 117.5 | 6 | 50 | 3 | 1581 | 1423 | 1028 | 79 | 71 | 51 |
| 4 Volt @ 85°C (3.2 Volt @ 105°C) | | | | | | | | | | | | | |
| TCJB227M004#0060 | B | 220 | 4 | 88 | 10 | 60 | 3 | 1190 | 1071 | 774 | 71 | 64 | 46 |
| TCJD337M004#0050 | D | 330 | 4 | 132 | 6 | 50 | 3 | 1732 | 1559 | 1126 | 87 | 78 | 56 |
| TCJY337M004#0050 | Y | 330 | 4 | 132 | 6 | 50 | 3 | 1581 | 1423 | 1028 | 79 | 71 | 51 |
| TCJD477M004#0050 | D | 470 | 4 | 188 | 6 | 50 | 3 | 1732 | 1559 | 1126 | 87 | 78 | 56 |
| TCJY477M004#0050 | Y | 470 | 4 | 188 | 6 | 50 | 3 | 1581 | 1423 | 1028 | 79 | 71 | 51 |
| 6.3 Volt @ 85°C (5 Volt @ 105°C) | | | | | | | | | | | | | |
| TCJN106M006#0500 | N | 10 | 6.3 | 6.0 | 6 | 500 | 3 | 316 | 285 | 206 | 158 | 142 | 103 |
| TCJN226M006#0500 | N | 22 | 6.3 | 13.2 | 10 | 500 | 3 | 316 | 285 | 206 | 158 | 142 | 103 |
| TCJK476M006#0150 | K | 47 | 6.3 | 28.2 | 6 | 150 | 3 | 658 | 592 | 428 | 99 | 89 | 64 |
| TCJK476M006#0200 | K | 47 | 6.3 | 28.2 | 6 | 200 | 3 | 570 | 513 | 371 | 114 | 103 | 74 |
| TCJR476M006#0500 | R | 47 | 6.3 | 28.2 | 10 | 500 | 3 | 332 | 298 | 216 | 166 | 149 | 108 |
| TCJT476M006#0070 | T | 47 | 6.3 | 28.2 | 8 | 70 | 3 | 1069 | 962 | 695 | 75 | 67 | 49 |
| TCJT686M006#0200 | T | 68 | 6.3 | 40.8 | 8 | 200 | 3 | 632 | 569 | 411 | 126 | 114 | 82 |
| TCJT107M006#0200 | T | 100 | 6.3 | 60 | 10 | 200 | 3 | 632 | 569 | 411 | 126 | 114 | 82 |
| TCJB157M006#0035 | B | 150 | 6.3 | 90 | 10 | 35 | 3 | 1558 | 1403 | 1013 | 55 | 49 | 35 |
| TCJY157M006#0040 | Y | 150 | 6.3 | 90 | 6 | 40 | 3 | 1768 | 1591 | 1149 | 71 | 64 | 46 |
| TCJD227M006#0040 | D | 220 | 6.3 | 132 | 6 | 40 | 3 | 1936 | 1743 | 1259 | 77 | 70 | 50 |
| TCJD227M006#0050 | D | 220 | 6.3 | 132 | 6 | 50 | 3 | 1732 | 1559 | 1126 | 87 | 78 | 56 |
| TCJY227M006#0050 | Y | 220 | 6.3 | 132 | 6 | 50 | 3 | 1581 | 1423 | 1028 | 79 | 71 | 51 |
| TCJD337M006#0040 | D | 330 | 6.3 | 198 | 6 | 40 | 3 | 1936 | 1743 | 1259 | 77 | 70 | 50 |
| TCJD337M006#0050 | D | 330 | 6.3 | 198 | 6 | 50 | 3 | 1732 | 1559 | 1126 | 87 | 78 | 56 |
| TCJY337M006#0040 | Y | 330 | 6.3 | 198 | 12 | 40 | 3 | 1768 | 1591 | 1149 | 71 | 64 | 46 |
| TCJY337M006#0050 | Y | 330 | 6.3 | 198 | 12 | 50 | 3 | 1581 | 1423 | 1028 | 79 | 71 | 51 |
| 10 Volt @ 85°C (8 Volt @ 105°C) | | | | | | | | | | | | | |
| TCJD107M010#0045 | D | 100 | 10 | 100 | 6 | 45 | 3 | 1826 | 1643 | 1187 | 82 | 74 | 53 |
| TCJD107M010#0055 | D | 100 | 10 | 100 | 6 | 55 | 3 | 1651 | 1486 | 1073 | 91 | 82 | 59 |
| TCJY107M010#0045 | Y | 100 | 10 | 100 | 6 | 45 | 3 | 1667 | 1500 | 1083 | 75 | 68 | 49 |
| TCJY107M010#0055 | Y | 100 | 10 | 100 | 6 | 55 | 3 | 1508 | 1357 | 980 | 83 | 75 | 54 |
| TCJD157M010#0045 | D | 150 | 10 | 150 | 6 | 45 | 3 | 1826 | 1643 | 1187 | 82 | 74 | 53 |
| TCJD157M010#0055 | D | 150 | 10 | 150 | 6 | 55 | 3 | 1651 | 1486 | 1073 | 91 | 82 | 59 |
| TCJY157M010#0045 | Y | 150 | 10 | 150 | 6 | 45 | 3 | 1667 | 1500 | 1083 | 75 | 68 | 49 |
| TCJY157M010#0055 | Y | 150 | 10 | 150 | 6 | 55 | 3 | 1508 | 1357 | 980 | 83 | 75 | 54 |
| TCJD227M010#0040 | D | 220 | 10 | 220 | 6 | 40 | 3 | 1936 | 1743 | 1259 | 77 | 70 | 50 |
| TCJD227M010#0050 | D | 220 | 10 | 220 | 6 | 50 | 3 | 1732 | 1559 | 1126 | 87 | 78 | 56 |
| TCJY227M010#0040 | Y | 220 | 10 | 220 | 6 | 40 | 3 | 1768 | 1591 | 1149 | 71 | 64 | 46 |
| TCJY227M010#0050 | Y | 220 | 10 | 220 | 6 | 50 | 3 | 1581 | 1423 | 1028 | 79 | 71 | 51 |



TCJ Series



Tantalum Solid Electrolytic Chip Capacitors with Conductive Polymer Electrode

RATINGS & PART NUMBER REFERENCE

| AVX Part No. | Case Size | Capacitance (µF) | Rated Voltage (V) | DCL (µA) Max. | DF % Max. | ESR Max. (mΩ) @100kHz | MSL | 100kHz RMS Current (mA) | | | 100kHz RMS Voltage (mV) | | |
|---|-----------|------------------|-------------------|---------------|-----------|-----------------------|-----|-------------------------|------|-------|-------------------------|------|-------|
| | | | | | | | | 25°C | 85°C | 105°C | 25°C | 85°C | 105°C |
| 16 Volt @ 85°C (12.8 Volt @ 105°C) | | | | | | | | | | | | | |
| TCJY336M016#0060 | Y | 33 | 16 | 52.8 | 6 | 60 | 3 | 1443 | 1299 | 938 | 87 | 78 | 56 |
| TCJY336M016#0070 | Y | 33 | 16 | 52.8 | 6 | 70 | 3 | 1336 | 1203 | 869 | 94 | 84 | 61 |
| TCJY476M016#0045 | Y | 47 | 16 | 75.2 | 6 | 45 | 3 | 1667 | 1500 | 1083 | 75 | 68 | 49 |
| TCJY476M016#0070 | Y | 47 | 16 | 75.2 | 6 | 70 | 3 | 1336 | 1203 | 869 | 94 | 84 | 61 |
| TCJD686M016#0045 | D | 68 | 16 | 108.8 | 6 | 45 | 3 | 1826 | 1643 | 1187 | 82 | 74 | 53 |
| TCJD686M016#0055 | D | 68 | 16 | 108.8 | 6 | 55 | 3 | 1651 | 1486 | 1073 | 91 | 82 | 59 |
| TCJY686M016#0045 | Y | 68 | 16 | 108.8 | 6 | 45 | 3 | 1667 | 1500 | 1083 | 75 | 68 | 49 |
| TCJY686M016#0055 | Y | 68 | 16 | 108.8 | 6 | 55 | 3 | 1508 | 1357 | 980 | 83 | 75 | 54 |
| TCJE107M016#0040 | E | 100 | 16 | 160.0 | 6 | 40 | 3 | 2031 | 1828 | 1320 | 81 | 73 | 53 |
| TCJE157M016#0040 | E | 150 | 16 | 240.0 | 6 | 40 | 3 | 2031 | 1828 | 1320 | 81 | 73 | 53 |
| 20 Volt @ 85°C (16 Volt @ 105°C) | | | | | | | | | | | | | |
| TCJY226M020#0070 | Y | 22 | 20 | 44.0 | 6 | 70 | 3 | 1336 | 1203 | 869 | 94 | 84 | 61 |
| TCJY336M020#0070 | Y | 33 | 20 | 66.0 | 6 | 70 | 3 | 1336 | 1203 | 869 | 94 | 84 | 61 |
| TCJY476M020#0070 | Y | 47 | 20 | 94.0 | 6 | 70 | 3 | 1336 | 1203 | 869 | 94 | 84 | 61 |
| TCJD686M020#0055 | D | 68 | 20 | 136.0 | 6 | 55 | 3 | 1651 | 1486 | 1073 | 91 | 82 | 59 |
| TCJE686M020#0045 | E | 68 | 20 | 136.0 | 6 | 45 | 3 | 1915 | 1723 | 1245 | 86 | 78 | 56 |
| TCJD107M020#0055 | D | 100 | 20 | 200.0 | 6 | 55 | 3 | 1651 | 1486 | 1073 | 91 | 82 | 59 |
| TCJE107M020#0045 | E | 100 | 20 | 200.0 | 6 | 45 | 3 | 1915 | 1723 | 1245 | 86 | 78 | 56 |
| 25 Volt @ 85°C (20 Volt @ 105°C) | | | | | | | | | | | | | |
| TCJP105M025#0500 | P | 1.0 | 25 | 2.5 | 6 | 500 | 3 | 346 | 312 | 225 | 173 | 156 | 113 |
| TCJB475M025#0150 | B | 4.7 | 25 | 11.8 | 6 | 150 | 3 | 753 | 677 | 489 | 113 | 102 | 73 |
| TCJB685M025#0150 | B | 6.8 | 25 | 17.0 | 6 | 150 | 3 | 753 | 677 | 489 | 113 | 102 | 73 |
| TCJB106M025#0150 | B | 10 | 25 | 25.0 | 6 | 150 | 3 | 753 | 677 | 489 | 113 | 102 | 73 |
| TCJB156M025#0100 | B | 15 | 25 | 37.5 | 6 | 100 | 3 | 922 | 830 | 599 | 92 | 83 | 60 |
| TCJB156M025#0150 | B | 15 | 25 | 37.5 | 6 | 150 | 3 | 753 | 677 | 489 | 113 | 102 | 73 |
| TCJB226M025#0150 | B | 22 | 25 | 55.0 | 6 | 150 | 3 | 753 | 677 | 489 | 113 | 102 | 73 |
| TCJC226M025#0100 | C | 22 | 25 | 55.0 | 6 | 100 | 3 | 1049 | 944 | 682 | 105 | 94 | 68 |
| TCJD226M025#0060 | D | 22 | 25 | 55.0 | 6 | 60 | 3 | 1581 | 1423 | 1028 | 95 | 85 | 62 |
| TCJD226M025#0100 | D | 22 | 25 | 55.0 | 6 | 100 | 3 | 1225 | 1102 | 796 | 122 | 110 | 80 |
| TCJY226M025#0070 | Y | 22 | 25 | 55.0 | 6 | 70 | 3 | 1336 | 1203 | 869 | 94 | 84 | 61 |
| TCJD336M025#0060 | D | 33 | 25 | 82.5 | 6 | 60 | 3 | 1581 | 1423 | 1028 | 95 | 85 | 62 |
| TCJD336M025#0100 | D | 33 | 25 | 82.5 | 6 | 100 | 3 | 1225 | 1102 | 796 | 122 | 110 | 80 |
| TCJY336M025#0070 | Y | 33 | 25 | 82.5 | 6 | 70 | 3 | 1336 | 1203 | 869 | 94 | 84 | 61 |
| TCJY336M025#0100 | Y | 33 | 25 | 82.5 | 6 | 100 | 3 | 1118 | 1006 | 727 | 112 | 101 | 73 |
| TCJD476M025#0060 | D | 47 | 25 | 117.5 | 6 | 60 | 3 | 1581 | 1423 | 1028 | 95 | 85 | 62 |
| TCJD476M025#0100 | D | 47 | 25 | 117.5 | 6 | 100 | 3 | 1225 | 1102 | 796 | 122 | 110 | 80 |
| TCJE476M025#0050 | E | 47 | 25 | 117.5 | 6 | 50 | 3 | 1817 | 1635 | 1181 | 91 | 82 | 59 |
| TCJE686M025#0050 | E | 68 | 25 | 170.0 | 6 | 50 | 3 | 1817 | 1635 | 1181 | 91 | 82 | 59 |
| TCJE107M025#0080 | E | 100 | 25 | 250.0 | 6 | 80 | 3 | 1436 | 1293 | 933 | 115 | 103 | 75 |
| 35 Volt @ 85°C (28 Volt @ 105°C) | | | | | | | | | | | | | |
| TCJB155M035#0200 | B | 1.5 | 35 | 5.3 | 6 | 200 | 3 | 652 | 587 | 424 | 130 | 117 | 85 |
| TCJB225M035#0200 | B | 2.2 | 35 | 7.7 | 6 | 200 | 3 | 652 | 587 | 424 | 130 | 117 | 85 |
| TCJB335M035#0200 | B | 3.3 | 35 | 11.6 | 6 | 200 | 3 | 652 | 587 | 424 | 130 | 117 | 85 |
| TCJB475M035#0200 | B | 4.7 | 35 | 16.5 | 6 | 200 | 3 | 652 | 587 | 424 | 130 | 117 | 85 |
| TCJC475M035#0200 | C | 4.7 | 35 | 16.5 | 6 | 200 | 3 | 742 | 667 | 482 | 148 | 133 | 96 |
| TCJC685M035#0200 | C | 6.8 | 35 | 23.8 | 6 | 200 | 3 | 742 | 667 | 482 | 148 | 133 | 96 |
| TCJB106M035#0200 | B | 10 | 35 | 35.0 | 6 | 200 | 3 | 652 | 587 | 424 | 130 | 117 | 85 |
| TCJC106M035#0200 | C | 10 | 35 | 35.0 | 6 | 200 | 3 | 742 | 667 | 482 | 148 | 133 | 96 |
| TCJC156M035#0200 | C | 15 | 35 | 52.5 | 6 | 200 | 3 | 742 | 667 | 482 | 148 | 133 | 96 |
| TCJY106M035#0070 | Y | 10 | 35 | 35.0 | 6 | 70 | 3 | 1336 | 1203 | 869 | 94 | 84 | 61 |
| TCJD156M035#0070 | D | 15 | 35 | 52.5 | 6 | 70 | 3 | 1464 | 1317 | 952 | 102 | 92 | 67 |
| TCJD156M035#0100 | D | 15 | 35 | 52.5 | 6 | 100 | 3 | 1225 | 1102 | 796 | 122 | 110 | 80 |
| TCJD226M035#0070 | D | 22 | 35 | 77.0 | 6 | 70 | 3 | 1464 | 1317 | 952 | 102 | 92 | 67 |
| TCJD226M035#0100 | D | 22 | 35 | 77.0 | 6 | 100 | 3 | 1225 | 1102 | 796 | 122 | 110 | 80 |
| TCJD336M035#0070 | D | 33 | 35 | 115.5 | 6 | 70 | 3 | 1464 | 1317 | 952 | 102 | 92 | 67 |
| TCJD336M035#0100 | D | 33 | 35 | 115.5 | 6 | 100 | 3 | 1225 | 1102 | 796 | 122 | 110 | 80 |
| TCJE336M035#0055 | E | 33 | 35 | 115.5 | 6 | 55 | 3 | 1732 | 1559 | 1126 | 95 | 86 | 62 |
| TCJE336M035#0070 | E | 33 | 35 | 115.5 | 6 | 70 | 3 | 1535 | 1382 | 998 | 107 | 97 | 70 |
| TCJE476M035#0055 | E | 47 | 35 | 164.5 | 6 | 55 | 3 | 1732 | 1559 | 1126 | 95 | 86 | 62 |

Moisture Sensitivity Level (MSL) is defined according to J-STD-020.

All technical data relates to an ambient temperature of +25°C. Capacitance and DF are measured at 120Hz, 0.5RMS with DC bias of 2.2 volts. DCL is measured at rated voltage after 5 minutes.

ESR allowed to move up to 1.25 times catalog limit post mounting.

For typical weight and composition see page 144.

NOTE: AVX reserves the right to supply a higher voltage rating or tighter tolerance part in the same case size, to the same reliability standards.



TCJ Series



Tantalum Solid Electrolytic Chip Capacitors with Conductive Polymer Electrode

RATINGS & PART NUMBER REFERENCE

| AVX Part No. | Case Size | Capacitance (µF) | Rated Voltage (V) | DCL (µA) Max. | DF % Max. | ESR Max. (mΩ) @100kHz | MSL | 100kHz RMS Current (mA) | | | 100kHz RMS Voltage (mV) | | |
|---|-----------|------------------|-------------------|---------------|-----------|-----------------------|-----|-------------------------|------|-------|-------------------------|------|-------|
| | | | | | | | | 25°C | 85°C | 105°C | 25°C | 85°C | 105°C |
| 50 Volt @ 85°C (40 Volt @ 105°C) | | | | | | | | | | | | | |
| TCJB684M050#0400 | B | 0.68 | 50 | 3.4 | 6 | 400 | 3 | 461 | 415 | 300 | 184 | 166 | 120 |
| TCJB105M050#0300 | B | 1.0 | 50 | 5.0 | 6 | 300 | 3 | 532 | 479 | 346 | 160 | 144 | 104 |
| TCJB155M050#0300 | B | 1.5 | 50 | 7.5 | 6 | 300 | 3 | 532 | 479 | 346 | 160 | 144 | 104 |
| TCJC155M050#0300 | C | 1.5 | 50 | 7.5 | 6 | 300 | 3 | 606 | 545 | 394 | 182 | 163 | 118 |
| TCJC225M050#0300 | C | 2.2 | 50 | 11 | 6 | 300 | 3 | 606 | 545 | 394 | 182 | 163 | 118 |
| TCJC335M050#0200 | C | 3.3 | 50 | 16.5 | 8 | 200 | 3 | 742 | 667 | 482 | 148 | 133 | 96 |
| TCJC475M050#0200 | C | 4.7 | 50 | 23.5 | 8 | 200 | 3 | 742 | 667 | 482 | 148 | 133 | 96 |
| TCJC685M050#0200 | C | 6.8 | 50 | 34.0 | 8 | 200 | 3 | 742 | 667 | 482 | 148 | 133 | 96 |
| TCJD685M050#0120 | D | 6.8 | 50 | 34.0 | 10 | 120 | 3 | 1118 | 1006 | 727 | 134 | 121 | 87 |
| TCJD106M050#0120 | D | 10 | 50 | 50.0 | 10 | 120 | 3 | 1118 | 1006 | 727 | 134 | 121 | 87 |
| TCJE106M050#0070 | E | 10 | 50 | 50.0 | 6 | 70 | 3 | 1535 | 1382 | 998 | 107 | 97 | 70 |
| TCJE106M050#0100 | E | 10 | 50 | 50.0 | 6 | 100 | 3 | 1285 | 1156 | 835 | 128 | 116 | 83 |
| TCJE156M050#0070 | E | 15 | 50 | 75.0 | 6 | 70 | 3 | 1535 | 1382 | 998 | 107 | 97 | 70 |
| TCJE156M050#0100 | E | 15 | 50 | 75.0 | 6 | 100 | 3 | 1285 | 1156 | 835 | 128 | 116 | 83 |
| 63 Volt @ 85°C (50.4 Volt @ 105°C) | | | | | | | | | | | | | |
| TCJB474M063#0400 | B | 0.47 | 63 | 3.0 | 8 | 400 | 3 | 461 | 415 | 300 | 184 | 166 | 120 |
| TCJB684M063#0300 | B | 0.68 | 63 | 4.3 | 8 | 300 | 3 | 532 | 479 | 346 | 160 | 144 | 104 |
| TCJB105M063#0300 | B | 1.0 | 63 | 6.3 | 8 | 300 | 3 | 532 | 479 | 346 | 160 | 144 | 104 |
| TCJC105M063#0300 | C | 1.0 | 63 | 6.3 | 6 | 300 | 3 | 606 | 545 | 394 | 182 | 163 | 118 |
| TCJC155M063#0300 | C | 1.5 | 63 | 9.5 | 6 | 300 | 3 | 606 | 545 | 394 | 182 | 163 | 118 |
| TCJC225M063#0200 | C | 2.2 | 63 | 13.9 | 6 | 200 | 3 | 742 | 667 | 482 | 148 | 133 | 96 |
| TCJC335M063#0200 | C | 3.3 | 63 | 20.8 | 6 | 200 | 3 | 742 | 667 | 482 | 148 | 133 | 96 |
| TCJC475M063#0200 | C | 4.7 | 63 | 29.6 | 6 | 200 | 3 | 742 | 667 | 482 | 148 | 133 | 96 |
| TCJD475M063#0120 | D | 4.7 | 63 | 29.6 | 6 | 120 | 3 | 1118 | 1006 | 727 | 134 | 121 | 87 |
| TCJD685M063#0120 | D | 6.8 | 63 | 42.8 | 6 | 120 | 3 | 1118 | 1006 | 727 | 134 | 121 | 87 |
| TCJE685M063#0100 | E | 6.8 | 63 | 42.8 | 6 | 100 | 3 | 1285 | 1156 | 835 | 128 | 116 | 83 |
| TCJE685M063#0150 | E | 6.8 | 63 | 42.8 | 6 | 150 | 3 | 1049 | 944 | 682 | 157 | 142 | 102 |
| TCJE106M063#0100 | E | 10 | 63 | 63.0 | 6 | 100 | 3 | 1285 | 1156 | 835 | 128 | 116 | 83 |
| TCJE106M063#0150 | E | 10 | 63 | 63.0 | 6 | 150 | 3 | 1049 | 944 | 682 | 157 | 142 | 102 |
| 75 Volt @ 85°C (60 Volt @ 105°C) | | | | | | | | | | | | | |
| TCJD475M075#0150 | D | 4.7 | 75 | 35.3 | 6 | 150 | 3 | 1000 | 900 | 650 | 150 | 135 | 98 |
| TCJD685M075#0120 | D | 6.8 | 75 | 51.0 | 6 | 120 | 3 | 1118 | 1006 | 727 | 134 | 121 | 87 |
| 100 Volt @ 85°C (80 Volt @ 105°C) | | | | | | | | | | | | | |
| TCJV685M100#0250 | V | 6.8 | 100 | 68.0 | 8 | 250 | 3 | 1000 | 900 | 650 | 250 | 225 | 163 |
| 125 Volt @ 85°C (100 Volt @ 105°C) | | | | | | | | | | | | | |
| TCJD335M125#0250 | D | 3.3 | 125 | 41.2 | 8 | 250 | 3 | 775 | 697 | 503 | 194 | 174 | 126 |

Moisture Sensitivity Level (MSL) is defined according to J-STD-020.

All technical data relates to an ambient temperature of +25°C. Capacitance and DF are measured at 120Hz, 0.5RMS with DC bias of 2.2 volts. DCL is measured at rated voltage after 5 minutes.

ESR allowed to move up to 1.25 times catalog limit post mounting.

For typical weight and composition see page 144.

NOTE: AVX reserves the right to supply a higher voltage rating or tighter tolerance part in the same case size, to the same reliability standards.

Voltage vs Temperature Rating

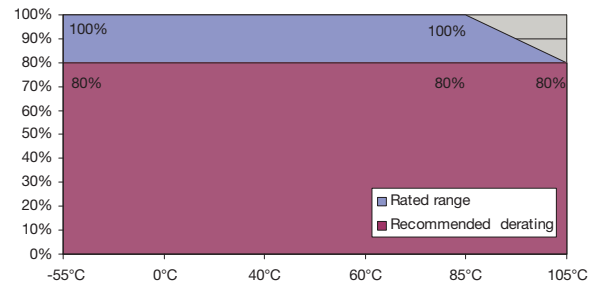

TCM Series



Tantalum Solid Electrolytic Chip Capacitors Conductive Polymer Multianode

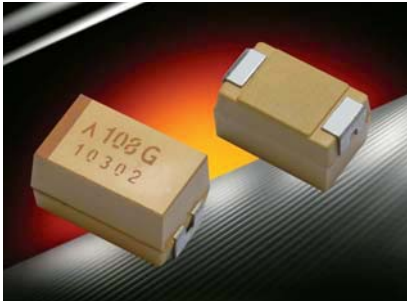

- Conductive polymer multianode
- Extremely Low ESR
- Reduced ignition failure mode
- 3x reflow 260°C compatible
- Volumetric efficiency
- High frequency capacitance retention

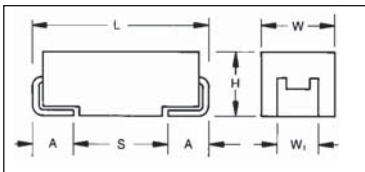

CASE DIMENSIONS: millimeters (inches)

| Code | EIA Code | EIA Metric | L±0.20 (0.008) | W+0.20 (0.008) -0.10 (0.004) | H+0.20 (0.008) -0.10 (0.004) | W ₁ ±0.20 (0.008) | A+0.30 (0.012) -0.20 (0.008) | S Min. |
|------|----------|------------|----------------|---------------------------------|---------------------------------|------------------------------|---------------------------------|--------------|
| E | 2917 | 7343-43 | 7.30 (0.287) | 4.30 (0.169) | 4.10 (0.162) | 2.40 (0.094) | 1.30 (0.051) | 4.40 (0.173) |

W₁ dimension applies to the termination width for A dimensional area only.

For part marking see page 151

HOW TO ORDER

| | | | | | | |
|------------|------------------------------|--|---------------------|--|--|-------------|
| TCM | E | 108 | M | 004 | R | 0010 |
| Type | Case Size See table above | Capacitance Code pF code: 1st two digits represent significant figures, 3rd digit represents multiplier (number of zeros to follow) | Tolerance M=±20% | Rated DC Voltage 004=4Vdc 006=6.3Vdc 010=10Vdc 035=35Vdc | Packaging R = Pure Tin 7" Reel S = Pure Tin 13" Reel | ESR in mΩ |

TECHNICAL SPECIFICATIONS

| | | | | | | |
|------------------------------------|--|-----|-----|----|----|--|
| Technical Data: | All technical data relate to an ambient temperature of +25°C | | | | | |
| Capacitance Range: | 22 μF to 1000 μF | | | | | |
| Capacitance Tolerance: | ±20% | | | | | |
| Leakage Current DCL: | 0.1CV | | | | | |
| Rated Voltage (V _R) | ≤ +85°C: | 4 | 6.3 | 10 | 35 | |
| Category Voltage (V _C) | ≤ +105°C: | 3.2 | 5 | 8 | 28 | |
| Surge Voltage (V _S) | ≤ +85°C: | 5.2 | 8 | 13 | 46 | |
| Surge Voltage (V _S) | ≤ +105°C: | 4 | 6 | 10 | 35 | |
| Temperature Range: | -55°C to +105°C | | | | | |
| Reliability: | 1% per 1000 hours at 85°C, V _R with 0.1Ω/V series impedance, 60% confidence level | | | | | |

TCM Series



Tantalum Solid Electrolytic Chip Capacitors Conductive Polymer Multianode

CAPACITANCE AND RATED VOLTAGE, VR (VOLTAGE CODE) RANGE (LETTER DENOTES CASE SIZE)

| Capacitance | | Rated Voltage DC (V _R) to 85°C | | | |
|-------------|------|--|----------|----------|---------|
| μF | Code | 4V (G) | 6.3V (J) | 10V (A) | 35V (V) |
| 22 | 226 | | | | E(25) |
| 33 | 336 | | | | |
| 47 | 476 | | | | |
| 68 | 686 | | | | |
| 100 | 107 | | | | |
| 150 | 157 | | | | |
| 220 | 227 | | | | |
| 330 | 337 | | | E(10,15) | |
| 470 | 477 | | | | |
| 680 | 687 | | E(12) | | |
| 1000 | 108 | E(10,12) | | | |
| 1500 | 158 | | | | |

Available Ratings, (ESR ratings in mΩ in brackets)

Engineering samples - please contact manufacturer

*Codes under development – subject to change

Note: Voltage ratings are minimum values. AVX reserves the right to supply higher ratings in the same case size, to the same reliability standards.

RATINGS & PART NUMBER REFERENCE

| AVX Part No. | Case Size | Capacitance (μF) | Rated Voltage (V) | DCL (μA) Max. | DF % Max. | ESR Max. (mΩ) @100kHz | MSL | 100kHz RMS Current (mA) | | | 100kHz RMS Voltage (mV) | | |
|---|-----------|------------------|-------------------|---------------|-----------|-----------------------|-----|-------------------------|------|-------|-------------------------|------|-------|
| | | | | | | | | 25°C | 85°C | 105°C | 25°C | 85°C | 105°C |
| 4 Volt @ 85°C (3.2 Volt @ 105°C) | | | | | | | | | | | | | |
| TCME108M004#0010 | E | 1000 | 4 | 400 | 8 | 10 | 3 | 5196 | 4677 | 3377 | 52 | 47 | 34 |
| TCME108M004#0012 | E | 1000 | 4 | 400 | 8 | 12 | 3 | 4743 | 4269 | 3083 | 57 | 51 | 37 |
| 6.3 Volt @ 85°C (5 Volt @ 105°C) | | | | | | | | | | | | | |
| TCME687M006#0012 | E | 680 | 6.3 | 408 | 8 | 12 | 3 | 4743 | 4269 | 3083 | 57 | 51 | 37 |
| 10 Volt @ 85°C (8 Volt @ 105°C) | | | | | | | | | | | | | |
| TCME337M010#0010 | E | 330 | 10 | 330 | 8 | 10 | 3 | 5196 | 4677 | 3377 | 52 | 47 | 34 |
| TCME337M010#0015 | E | 330 | 10 | 330 | 8 | 15 | 3 | 4243 | 3818 | 2758 | 64 | 57 | 41 |
| 35 Volt @ 85°C (28 Volt @ 105°C) | | | | | | | | | | | | | |
| TCME226M035#0025 | E | 22 | 35 | 77 | 8 | 25 | 3 | 3286 | 2958 | 2136 | 82 | 74 | 53 |

Moisture Sensitivity Level (MSL) is defined according to J-STD-020.

All technical data relates to an ambient temperature of +25°C. Capacitance and DF are measured at 120Hz, 0.5RMS with DC bias of 2.2 volts. DCL is measured at rated voltage after 5 minutes.

ESR allowed to move up to 1.25 times catalog limit post mounting.

For typical weight and composition see page 144.

NOTE: AVX reserves the right to supply a higher voltage rating or tighter tolerance part in the same case size, to the same reliability standards.

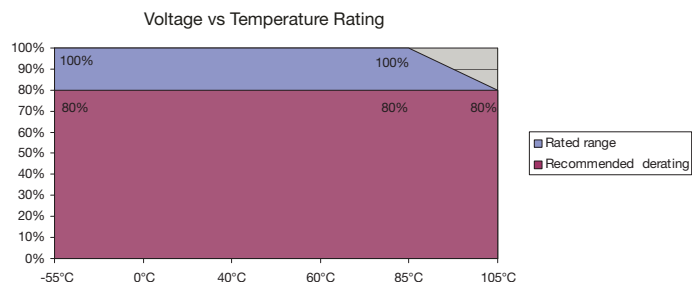

TCN Series



Tantalum Solid Electrolytic Chip Capacitors Undertab Series with Conductive Polymer Electrode



- Conductive polymer electrode reduces ignition failure mode
- Lower ESR
- Undertab terminations layout:
 - High Volumetric Efficiency
 - High PCB assembly density
 - High capacitance in smaller dimensions
- 3x reflow 260°C compatible
- Consumer applications (e.g. mobiles, MP3 etc.)
- 4 case sizes available

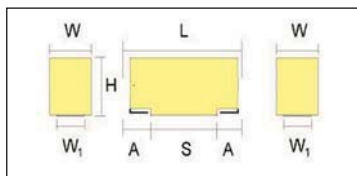

For part marking see page 151

CASE DIMENSIONS: millimeters (inches)

| Code | EIA Code | EIA Metric | L±0.20 (0.008) | W±0.20 (0.008) -0.10 (0.004) | H max. | W _i ±0.20 (0.008) | A±0.30 (0.012) -0.20 (0.008) |
|------|----------|------------|----------------|------------------------------|--------------|------------------------------|------------------------------|
| L | 1210 | 3528-10 | 3.50 (0.138) | 2.80 (0.110) | 1.00 (0.039) | 2.20 (0.087) | 0.80 (0.031) |
| N | 0805 | 2012-10 | 2.05 (0.081) | 1.30 (0.051) | 1.00 (0.039) | 1.00 (0.039) | 0.50 (0.020) |
| S | 1206 | 3216-12 | 3.20 (0.126) | 1.60 (0.063) | 1.20 (0.047) | 1.20 (0.047) | 0.80 (0.031) |
| T | 1210 | 3528-12 | 3.50 (0.138) | 2.80 (0.110) | 1.20 (0.047) | 2.20 (0.087) | 0.80 (0.031) |

W₁ dimension applies to the termination width for A dimensional area only.

HOW TO ORDER

TCN

Type

L

Case Size
See table above

157

Capacitance Code
pF code: 1st two digits represent significant figures, 3rd digit represents multiplier (number of zeros to follow)

M

Tolerance
M = ±20%

006

Rated DC Voltage
004 = 4Vdc
006 = 6.3Vdc
010 = 10Vdc

R

Packaging
R = Pure Tin 7" Reel
S = Pure Tin 13" Reel

0200

ESR in mΩ

TECHNICAL SPECIFICATIONS

| | | | | | |
|------------------------------------|---|-----|-----|----|--|
| Technical Data: | All technical data relate to an ambient temperature of +25°C | | | | |
| Capacitance Range: | 15µF to 470 µF | | | | |
| Capacitance Tolerance: | ±20% | | | | |
| Rated Voltage (V _R) | ≤ +85°C: | 4 | 6.3 | 10 | |
| Category Voltage (V _C) | ≤ +105°C: | 3.2 | 5 | 8 | |
| Surge Voltage (V _S) | ≤ +85°C: | 5.2 | 8 | 13 | |
| Surge Voltage (V _S) | ≤ +105°C: | 4 | 6 | 10 | |
| Temperature Range: | -55°C to +105°C | | | | |
| Reliability: | 1% per 1000 hours at 85°C, V _R with 0.1V _R series impedance with 60% confidence level | | | | |

Tantalum Solid Electrolytic Chip Capacitors Undertab Series with Conductive Polymer Electrode

CAPACITANCE AND RATED VOLTAGE, VR (VOLTAGE CODE) RANGE (LETTER DENOTES CASE SIZE)

| Capacitance | | Rated Voltage DC to 85°C / 0.66DC to 105°C | | |
|-------------|------|--|------------------------------------|------------------------------------|
| µF | Code | 4V (G) | 6.3V (J) | 10V (A) |
| 15 | 156 | | | N(500)* |
| 22 | 226 | | | N(500)* |
| 33 | 336 | N(500)* | K(500)*/N(500)* | K(500)*/N(500)* |
| 47 | 476 | N(500)* | K(500)* N(70,200,350)*/N(500) | K(500)*/S(500)* |
| 68 | 686 | K(500)*/N(500)* | K(500)*/S(500)* | G(150)*/L(150)* S(500)* |
| 100 | 107 | K(500)*/S(500)* | G(200)*/L(200)/S(250)* | G(150)*/L(150)* S(150)*/T(150)* |
| 150 | 157 | G(200)*/L(200)* S(500)* | K(200)* L(200)/S(200) T(200) | G(150)*/H(150)* T(150)* |
| 220 | 227 | G(200)*/L(150)* S(200)*/T(150)* | H(100,200)*/T(200)* | H(150)* |
| 330 | 337 | H(150)*/T(150)* | H(200)* | |
| 470 | 477 | H(150)* | | |

Available Ratings, (ESR ratings in mOhms in brackets)

Engineering samples - please contact manufacturer

*Codes under development - subject to change

Note: Voltage ratings are minimum values. AVX reserves the right to supply higher ratings in the same case size, to the same reliability standards.

RATINGS & PART NUMBER REFERENCE

| AVX Part No. | Case Size | Capacitance (µF) | Rated Voltage (V) | DCL (µA) Max. | DF % Max. | ESR Max. (mΩ) @100kHz | MSL | 100kHz RMS Current (mA) | | | 100kHz RMS Voltage (mV) | | |
|---|-----------|------------------|-------------------|---------------|-----------|-----------------------|-----|-------------------------|------|-------|-------------------------|------|-------|
| | | | | | | | | 25°C | 85°C | 105°C | 25°C | 85°C | 105°C |
| 6.3 Volt @ 85°C (5 Volt @ 105°C) | | | | | | | | | | | | | |
| TCNN476M006#0500 | N | 47 | 6.3 | 28.2 | 10 | 500 | 3 | 283 | 255 | 184 | 141 | 127 | 92 |
| TCNL107M006#0200 | L | 100 | 6.3 | 60 | 10 | 200 | 3 | 548 | 493 | 356 | 110 | 99 | 71 |
| TCNL157M006#0200 | L | 150 | 6.3 | 90 | 10 | 200 | 3 | 548 | 493 | 356 | 110 | 99 | 71 |
| TCNS157M006#0200 | S | 150 | 6.3 | 90 | 10 | 200 | 3 | 524 | 472 | 341 | 105 | 94 | 68 |
| TCNT157M006#0200 | T | 150 | 6.3 | 90 | 10 | 200 | 3 | 592 | 532 | 385 | 118 | 106 | 77 |
| TCNT227M006#0200 | T | 220 | 6.3 | 132 | 10 | 200 | 3 | 592 | 532 | 385 | 118 | 106 | 77 |

Moisture Sensitivity Level (MSL) is defined according to J-STD-020.

All technical data relates to an ambient temperature of +25°C. Capacitance and DF are measured at 120Hz, 0.5RMS with DC bias of 2.2 volts.

DCL is measured at rated voltage after 5 minutes.

ESR allowed to move up to 1.25 times catalog limit post mounting.

For typical weight and composition see page 144.

NOTE: AVX reserves the right to supply a higher voltage rating or tighter tolerance part in the same case size, to the same reliability standards.

Voltage vs Temperature Rating

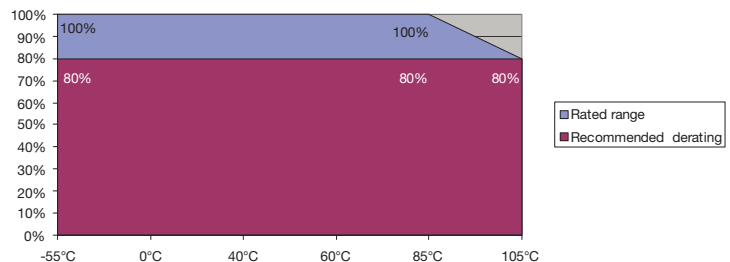

F38 Series

Conductive Polymer, Miniature, Frameless®



FRAMELESS™



- Compliant to the RoHS directive (2002/95/EC).

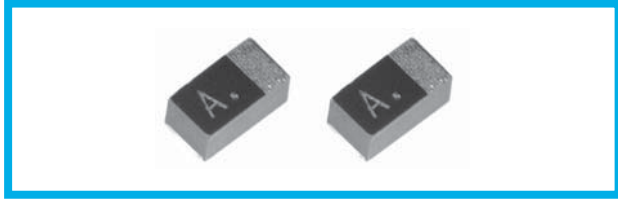

Applications

- Smartphone
- Wireless module
- Tablet PC
- Portable game

Catalog Numbering (Example: 10V 2.2uF)

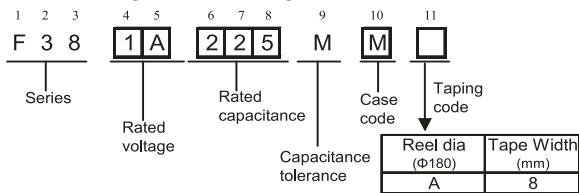

Dimensions

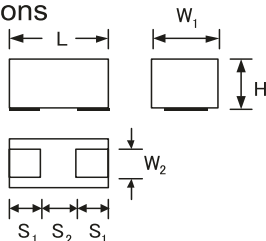

| Case Code | L | W ₁ | W ₂ | H | S ₁ | S ₂ |
|-----------|-------------------------------------|--------------------------------------|----------------|---------|----------------|----------------|
| M | 1.6 ^{+0.2} _{-0.1} | 0.85 ^{+0.2} _{-0.1} | 0.65±0.1 | 0.8±0.1 | 0.5±0.1 | 0.6±0.1 |
| S | 2.0 ^{+0.2} _{-0.1} | 1.25 ^{+0.2} _{-0.1} | 0.9±0.1 | 0.8±0.1 | 0.5±0.1 | 1.0±0.1 |

Marking

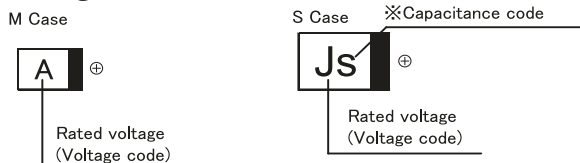

Standard ratings

| μF | V | | | ※ Capacitance code | | |
|-----|------|----|-----|--------------------|-------|-----|
| | Code | 4 | 6.3 | | 10 | |
| 2.2 | 225 | 0G | 0J | 1A | M | - |
| 4.7 | 475 | | | | M | - |
| 10 | 106 | | | | (M) | a |
| 22 | 226 | | | | (M) | (S) |
| 47 | 476 | | | | (M)·S | j |
| 100 | 107 | | | | (S) | A |

() The series in parentheses are being developed. Please contact to your local Nichicon sales office when these series are being designed in your application.

Specifications

| Item | Performance Characteristics |
|------------------------------|---|
| Category | -55~+105°C (Rated temperature : +85°C) |
| Temperature Range | |
| Capacitance Tolerance | ±20% (120Hz) |
| Dissipation Factor | Refer to the table below |
| E.S.R. | Refer to the table below |
| Leakage Current | Refer to the table below Provided that After 5 minute's application of rated voltage, leakage current at 105°C, 10 times or less than 20°C specified value. |
| Damp Heat (Steady State) | At 40°C, 90~95% R.H., For 500hours (No voltage applied) Capacitance Change...Refer to the table below (1) Dissipation Factor...200% or less of initial specified value Leakage Current...300% or less of initial specified value |
| Temperature Cycles | At -55°C / +105°C, For 30 minutes each, 5 cycles Capacitance Change...Refer to the table below (1) Dissipation Factor...200% or less of initial specified value Leakage Current...400% or less of initial specified value |
| Resistance to Soldering Heat | 10 seconds reflow at 240°C Capacitance Change...Refer to the table below (1) Dissipation Factor...200% or less of initial specified value Leakage Current...300% or less of initial specified value |
| Surge | After application of surge in series with a 1kΩ resistor at the rate of 30 seconds ON, 30 seconds OFF, for 1000 successive test cycles at 85°C, capacitors meet the characteristics requirements tableed below. Capacitance Change...Refer to the table below (1) Dissipation Factor...200% or less of initial specified value Leakage Current...300% or less of initial specified value |
| Endurance | After 1000 hours' application of rated voltage in series with a 3Ω resistor at 85°C, capacitors meet the characteristic requirements tableed below Capacitance Change...Refer to the table below (1) Dissipation Factor...200% or less of initial specified value Leakage Current...400% or less of initial specified value |
| Shear Test | After applying the pressure load of 5N for 10±1 seconds horizontally to the center of capacitor side body which has no electrode and has been soldered beforehand on an substrate, there shall be found neither exfoliation nor its sign at the terminal electrode. 5N (0.51kg·f) For 10 ± 1seconds |
| Terminal Strength | Keeping a capacitor surface-mounted on a substrate upside down and supporting the substrate at both of the opposite bottom points 45mm apart from the center of the capacitor, the pressure strength is applied with a specified jig at the center of the substrate so that the substrate may bend by 1mm as illustrated. Then, there shall be found no remarkable abnormality on the capacitor terminals. R230 45 45 |

Standard ratings

| Rated Volt | Rated Capacitance (μF) | Case code | Part Number | *2 Leakage Current (uA) | Dissipation Factor (%@120Hz) | ESR (mΩ@100kHz) | *1 ΔC/C (%) |
|------------|------------------------|-----------|-------------|-------------------------|------------------------------|-----------------|-------------|
| 6.3V | 47 | S | F380J476MSA | 29.6 | 10 | 200 | * |
| 10V | 2.2 | M | F381A225MMA | 10.0 | 6 | 500 | * |
| | 4.7 | M | F381A475MMA | 10.0 | 6 | 500 | * |

*1: ΔC/C Marked "※"

| Item | M Case (%) |
|------------------------------|------------|
| Damp heat, steady state | -20~+30 |
| Rapid change of temperature | ±20 |
| Resistance to soldering heat | ±20 |
| Surge | ±20 |
| Endurance | ±20 |

*2: Leakage Current

After 5 minute's application of rated voltage, leakage current at 20°C.

The correlations among rated voltage, surge voltage and derated voltage

| Rated voltage(V) | 6.3 | 10 |
|--------------------------|-----|----|
| 85°C Surge voltage(V) | 8 | 13 |
| 105°C Derated voltage(V) | 5 | 8 |

(Notice) Design, Specifications are subject to change without notice.



TRJ Series



Professional Tantalum Chip Capacitor



- Improved reliability – 2x standard
- DCL reduced by 25% to 0.0075 CV
- Robust against higher thermo-mechanical stresses during assembly process
- CV range: 0.10-470µF / 4-50V
- 5 case sizes available
- 123 low ESR parts released
- Automotive, medical, aerospace, military and other high-end applications



SnPb termination option is not RoHS compliant.

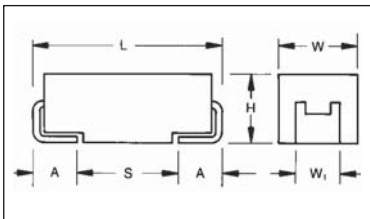

For part marking see page 151

CASE DIMENSIONS: millimeters (inches)

| Code | EIA Code | EIA Metric | L±0.20 (0.008) | W+0.20 (0.008) -0.10 (0.004) | H+0.20 (0.008) -0.10 (0.004) | W ₁ ±0.20 (0.008) -0.20 (0.008) | A+0.30 (0.012) -0.20 (0.008) | S Min. |
|------|----------|------------|----------------|------------------------------|------------------------------|--|------------------------------|--------------|
| A | 1206 | 3216-18 | 3.20 (0.126) | 1.60 (0.063) | 1.60 (0.063) | 1.20 (0.047) | 0.80 (0.031) | 1.10 (0.043) |
| B | 1210 | 3528-21 | 3.50 (0.138) | 2.80 (0.110) | 1.90 (0.075) | 2.20 (0.087) | 0.80 (0.031) | 1.40 (0.055) |
| C | 2312 | 6032-28 | 6.00 (0.236) | 3.20 (0.126) | 2.60 (0.102) | 2.20 (0.087) | 1.30 (0.051) | 2.90 (0.114) |
| D | 2917 | 7343-31 | 7.30 (0.287) | 4.30 (0.169) | 2.90 (0.114) | 2.40 (0.094) | 1.30 (0.051) | 4.40 (0.173) |
| E | 2917 | 7343-43 | 7.30 (0.287) | 4.30 (0.169) | 4.10 (0.162) | 2.40 (0.094) | 1.30 (0.051) | 4.40 (0.173) |

W₁ dimension applies to the termination width for A dimensional area only.

HOW TO ORDER

| | | | | | | | |
|------------|------------------------------|--|-------------------------------|--|---|---|--|
| TRJ | B | 105 | * | 035 | R | RJ | - |
| Type | Case Size See table above | Capacitance Code pF code: 1st two digits represent significant figures, 3rd digit represents multiplier (number of zeros to follow) | Tolerance K=±10% M=±20% | Rated DC Voltage 004 = 4V 006 = 6.3V 010 = 10V 016 = 16V 020 = 20V 025 = 25V 035 = 35V 050 = 50V | Packaging R = Pure Tin 7" Reel S = Pure Tin 13" Reel A = Gold Plating 7" Reel B = Gold Plating 13" Reel H = Tin Lead 7" Reel (Contact Manufacturer) K = Tin Lead 13" Reel (Contact Manufacturer) H, K = Non RoHS | Standard Suffix OR 0100 Low ESR in mΩ | Additional characters may be added for special requirements V = Dry pack Option (selected codes only) |

TECHNICAL SPECIFICATIONS

| | | | | | | | | | | |
|------------------------------------|--|-----|-----|----|----|----|----|----|----|--|
| Technical Data: | All technical data relate to an ambient temperature of +25°C | | | | | | | | | |
| Capacitance Range: | 0.10 µF to 470 µF | | | | | | | | | |
| Capacitance Tolerance: | ±10%; ±20% | | | | | | | | | |
| Leakage Current DCL: | 0.0075CV | | | | | | | | | |
| Rated Voltage (V _R) | ≤ +85°C: | 4 | 6.3 | 10 | 16 | 20 | 25 | 35 | 50 | |
| Category Voltage (V _C) | ≤ +125°C: | 2.7 | 4 | 7 | 10 | 13 | 17 | 23 | 33 | |
| Surge Voltage (V _S) | ≤ +85°C: | 5.2 | 8 | 13 | 20 | 26 | 32 | 46 | 65 | |
| Surge Voltage (V _S) | ≤ +125°C: | 3.4 | 5 | 8 | 13 | 16 | 20 | 28 | 40 | |
| Temperature Range: | -55°C to +125°C | | | | | | | | | |
| Reliability: | 0.5% per 1000 hours at 85°C, V _R with 0.1Ω/V series impedance, 60% confidence level | | | | | | | | | |
| Termination Plating: | Sn Plating (standard), Gold and SnPb Plating upon request Meets requirements of AEC-Q200 | | | | | | | | | |



Professional Tantalum Chip Capacitor

CAPACITANCE AND RATED VOLTAGE, VR (VOLTAGE CODE) RANGE (LETTER DENOTES CASE SIZE)

| Capacitance | | Rated Voltage DC (V _R) to 85°C | | | | | | | |
|-------------|------|--|-------------------------|-------------------------------------|---------------------------|--------------------------|------------------------|--------------------------|------------------------|
| μF | Code | 4V (G) | 6.3V (J) | 10V (A) | 16V (C) | 20V (D) | 25V (E) | 35V (V) | 50V (T) |
| 0.10 | 104 | | | | | | | A | |
| 0.15 | 154 | | | | | | | A, A(6000) | |
| 0.22 | 224 | | | | | | | A, A(6000) | A, A(7000) |
| 0.33 | 334 | | | | | | | A, A(6000) | A |
| 0.47 | 474 | | | | | | A, A(7000) | A, A(4000) | B |
| 0.68 | 684 | | | | | | A, A(6000) | A, A(6000) | B, B(2000) |
| 1.0 | 105 | | | | A | A, A(3000) | A, A(3000) | A, B, A(3000), B(2000) | C, B, B(2000) |
| 1.5 | 155 | | | A | | A, A(3000) | A, B, A(3000) | A, B, A(2000), B(2500) | C, C(1500) |
| 2.2 | 225 | | | A | A, A(3500) | A, A(3000) | A, B, A(1600), B(1200) | B, B(2000) | C, D, C(1000), D(1200) |
| 3.3 | 335 | | | | A, B, A(3500) | A, B, A(2500), B(1300) | B, B(2000) | B, C, D, B(1000), C(800) | C, D, C(1000), D(800) |
| 4.7 | 475 | | | A, A(2000) | A, B, A(2000), B(1500) | A, B, A(1800), B(1000) | B, B(1000) | B, C, D, B(1500), C(600) | D, D(600) |
| 6.8 | 685 | | | A, B, A(1800) | A, B, C, A(1500), B(1200) | B, C, B(1000) | B, C, B(1000), C(600) | C, D, C(600) | D |
| 10 | 106 | | A, B, A(1500) | A, B, A(1800), B(800) | B, C, B(800) | B, C, B(1000), C(500) | C, D, C(600) | C, D, C(600), D(250,400) | E, E(300,400) |
| 15 | 156 | B | A, B, A(1500), B(700) | A, B, C, A(1000), B(600) | B, B(800) | B, C, D, B(500), C(400) | C, D, C(500), D(300) | D, D(225) | |
| 22 | 226 | | A, B, C, A(900), B(600) | B, B(700) | B, C, D, B(600), C(350) | C, D, C(400), D(150,300) | D, D(300) | D, D(200,400) | |
| 33 | 336 | C | B, C, B(600) | B, C, D, B(650), C(300) | C, C(300) | C, D, C(300), D(250) | D, D(400) | E, E(150,250) | |
| 47 | 476 | | B, C, B(500), C(250) | C, D, C(300) | C, D, C(350), D(200) | D, D(200) | D, E, D(250), E(150) | | |
| 68 | 686 | | C, C(200) | C, C(300) | C, D, C(200), D(150) | D, E, D(200), E(120,200) | | | |
| 100 | 107 | | C, C(300) | C, D, E, C(200), D(100,150), E(100) | D, E, D(150), E(150) | E, E(150) | | | |
| 150 | 157 | | C, D, C(300), D(150) | D, E, D(150), E(150) | E, E(150) | | | | |
| 220 | 227 | | D, D(150) | D, E, E(150) | U, U(200) | | | | |
| 330 | 337 | | D, E, E(150) | E, E(100) | | | | | |
| 470 | 477 | | E, E(200) | | | | | | |

Not recommended for new designs, higher voltage or smaller case size substitution are offered.

Available Ratings, (ESR ratings in mOhms in brackets)

Engineering samples - please contact manufacturer

*Codes under development - subject to change

Note: Voltage ratings are minimum values. AVX reserves the right to supply higher ratings in the same case size, to the same reliability standards.

TRJ Series



Professional Tantalum Chip Capacitor

RATINGS & PART NUMBER REFERENCE

| AVX Part No. | Case Size | Capacitance (µF) | Rated Voltage (V) | DCL (µA) Max. | DF % Max. | ESR Max. (mΩ) @100kHz | MSL | 100kHz RMS Current (mA) | | | 100kHz RMS Voltage (mV) | | |
|---|-----------|------------------|-------------------|---------------|-----------|-----------------------|-----------------|-------------------------|------|-------|-------------------------|------|-------|
| | | | | | | | | 25°C | 85°C | 125°C | 25°C | 85°C | 125°C |
| 4 Volt @ 85°C (2.7 Volt @ 125°C) | | | | | | | | | | | | | |
| TRJB156*004#RJ | B | 15 | 4 | 0.45 | 6 | 3000 | 1 | 168 | 151 | 67 | 505 | 454 | 202 |
| TRJC336*004#RJ | C | 33 | 4 | 1.0 | 6 | 2000 | 1 | 235 | 211 | 94 | 469 | 422 | 188 |
| 6.3 Volt @ 85°C (4 Volt @ 125°C) | | | | | | | | | | | | | |
| TRJA106*006#RJ | A | 10 | 6.3 | 0.45 | 6 | 2200 | 1 | 185 | 166 | 74 | 406 | 366 | 162 |
| TRJA106*006#1500 | A | 10 | 6.3 | 0.45 | 6 | 1500 | 1 | 224 | 201 | 89 | 335 | 302 | 134 |
| TRJB106*006#RJ | B | 10 | 6.3 | 0.45 | 6 | 3000 | 1 | 168 | 151 | 67 | 505 | 454 | 202 |
| TRJA156*006#RJ | A | 15 | 6.3 | 0.68 | 6 | 2030 | 1 | 192 | 173 | 77 | 390 | 351 | 156 |
| TRJA156*006#1500 | A | 15 | 6.3 | 0.68 | 6 | 1500 | 1 | 224 | 201 | 89 | 335 | 302 | 134 |
| TRJB156*006#RJ | B | 15 | 6.3 | 0.68 | 6 | 2030 | 1 | 205 | 184 | 82 | 415 | 374 | 166 |
| TRJB156*006#0700 | B | 15 | 6.3 | 0.68 | 6 | 700 | 1 | 348 | 314 | 139 | 244 | 220 | 98 |
| TRJA226*006#RJ | A | 22 | 6.3 | 0.99 | 6 | 1700 | 1 | 210 | 189 | 84 | 357 | 321 | 143 |
| TRJA226*006#0900 | A | 22 | 6.3 | 0.99 | 6 | 900 | 1 | 289 | 260 | 115 | 260 | 234 | 104 |
| TRJB226*006#RJ | B | 22 | 6.3 | 0.99 | 6 | 1880 | 1 | 213 | 191 | 85 | 400 | 360 | 160 |
| TRJB226*006#0600 | B | 22 | 6.3 | 0.99 | 6 | 600 | 1 | 376 | 339 | 151 | 226 | 203 | 90 |
| TRJC226*006#RJ | C | 22 | 6.3 | 0.99 | 6 | 2000 | 1 | 235 | 211 | 94 | 469 | 422 | 188 |
| TRJB336*006#RJ | B | 33 | 6.3 | 1.5 | 6 | 1740 | 1 | 221 | 199 | 88 | 385 | 346 | 154 |
| TRJB336*006#0600 | B | 33 | 6.3 | 1.5 | 6 | 600 | 1 | 376 | 339 | 151 | 226 | 203 | 90 |
| TRJC336*006#RJ | C | 33 | 6.3 | 1.5 | 6 | 1800 | 1 | 247 | 222 | 99 | 445 | 400 | 178 |
| TRJB476*006#RJ | B | 47 | 6.3 | 2.1 | 6 | 1620 | 1 | 229 | 206 | 92 | 371 | 334 | 148 |
| TRJB476*006#0500 | B | 47 | 6.3 | 2.1 | 6 | 500 | 1 | 412 | 371 | 165 | 206 | 186 | 82 |
| TRJC476*006#RJ | C | 47 | 6.3 | 2.1 | 6 | 540 | 1 | 451 | 406 | 181 | 244 | 219 | 97 |
| TRJC476*006#0250 | C | 47 | 6.3 | 2.1 | 6 | 250 | 1 | 663 | 597 | 265 | 166 | 149 | 66 |
| TRJC686*006#RJ | C | 68 | 6.3 | 3.1 | 6 | 490 | 1 | 474 | 426 | 190 | 232 | 209 | 93 |
| TRJC686*006#0200 | C | 68 | 6.3 | 3.1 | 6 | 200 | 1 | 742 | 667 | 297 | 148 | 133 | 59 |
| TRJC107*006#RJ | C | 100 | 6.3 | 4.5 | 6 | 440 | 1 | 500 | 450 | 200 | 220 | 198 | 88 |
| TRJC107*006#0300 | C | 100 | 6.3 | 4.5 | 6 | 300 | 1 | 606 | 545 | 242 | 182 | 163 | 73 |
| TRJC157*006#RJ | C | 150 | 6.3 | 6.8 | 8 | 500 | 1 | 469 | 422 | 188 | 235 | 211 | 94 |
| TRJC157*006#0300 | C | 150 | 6.3 | 6.8 | 8 | 300 | 1 | 606 | 545 | 242 | 182 | 163 | 73 |
| TRJD157*006#RJ | D | 150 | 6.3 | 6.8 | 6 | 400 | 1 | 612 | 551 | 245 | 245 | 220 | 98 |
| TRJD157*006#0150 | D | 150 | 6.3 | 6.8 | 6 | 150 | 1 | 1000 | 900 | 400 | 150 | 135 | 60 |
| TRJD227*006#RJ | D | 220 | 6.3 | 9.9 | 8 | 360 | 1 | 645 | 581 | 258 | 232 | 209 | 93 |
| TRJD227*006#0150 | D | 220 | 6.3 | 9.9 | 8 | 150 | 1 | 1000 | 900 | 400 | 150 | 135 | 60 |
| TRJD337*006#RJ | D | 330 | 6.3 | 14 | 8 | 400 | 1 | 612 | 551 | 245 | 245 | 220 | 98 |
| TRJE337*006#RJ | E | 330 | 6.3 | 14 | 8 | 330 | 1 ¹⁾ | 707 | 636 | 283 | 233 | 210 | 93 |
| TRJE337*006#0150 | E | 330 | 6.3 | 14 | 8 | 150 | 1 ¹⁾ | 1049 | 944 | 420 | 157 | 142 | 63 |
| TRJE477*006#RJ | E | 470 | 6.3 | 21 | 8 | 250 | 1 ¹⁾ | 812 | 731 | 325 | 203 | 183 | 81 |
| TRJE477*006#0200 | E | 470 | 6.3 | 21 | 8 | 200 | 1 ¹⁾ | 908 | 817 | 363 | 182 | 163 | 73 |
| 10 Volt @ 85°C (7 Volt @ 125°C) | | | | | | | | | | | | | |
| TRJA155*010#RJ | A | 1.5 | 10 | 0.30 | 6 | 7000 | 1 | 104 | 93 | 41 | 725 | 652 | 290 |
| TRJA225*010#RJ | A | 2.2 | 10 | 0.30 | 6 | 7000 | 1 | 104 | 93 | 41 | 725 | 652 | 290 |
| TRJA475*010#RJ | A | 4.7 | 10 | 0.35 | 6 | 2900 | 1 | 161 | 145 | 64 | 466 | 420 | 187 |
| TRJA475*010#2000 | A | 4.7 | 10 | 0.35 | 6 | 2000 | 1 | 194 | 174 | 77 | 387 | 349 | 155 |
| TRJA685*010#RJ | A | 6.8 | 10 | 0.51 | 6 | 2650 | 1 | 168 | 151 | 67 | 446 | 401 | 178 |
| TRJA685*010#1800 | A | 6.8 | 10 | 0.51 | 6 | 1800 | 1 | 204 | 184 | 82 | 367 | 331 | 147 |
| TRJB685*010#RJ | B | 6.8 | 10 | 0.51 | 6 | 3000 | 1 | 168 | 151 | 67 | 505 | 454 | 202 |
| TRJA106*010#RJ | A | 10 | 10 | 0.75 | 6 | 2200 | 1 | 185 | 166 | 74 | 406 | 366 | 162 |
| TRJA106*010#1800 | A | 10 | 10 | 0.75 | 6 | 1800 | 1 | 204 | 184 | 82 | 367 | 331 | 147 |
| TRJB106*010#RJ | B | 10 | 10 | 0.75 | 6 | 2200 | 1 | 197 | 177 | 79 | 432 | 389 | 173 |
| TRJB106*010#0800 | B | 10 | 10 | 0.75 | 6 | 800 | 1 | 326 | 293 | 130 | 261 | 235 | 104 |
| TRJA156*010#RJ | A | 15 | 10 | 1.10 | 6 | 1800 | 1 | 204 | 184 | 82 | 367 | 331 | 147 |
| TRJA156*010#1000 | A | 15 | 10 | 1.10 | 6 | 1000 | 1 | 274 | 246 | 110 | 274 | 246 | 110 |
| TRJB156*010#RJ | B | 15 | 10 | 1.1 | 6 | 2030 | 1 | 205 | 184 | 82 | 415 | 374 | 166 |
| TRJB156*010#0600 | B | 15 | 10 | 1.1 | 6 | 600 | 1 | 376 | 339 | 151 | 226 | 203 | 90 |
| TRJC156*010#RJ | C | 15 | 10 | 1.1 | 6 | 2000 | 1 | 235 | 211 | 94 | 469 | 422 | 188 |
| TRJB226*010#RJ | B | 22 | 10 | 1.7 | 6 | 1880 | 1 | 213 | 191 | 85 | 400 | 360 | 160 |
| TRJB226*010#0700 | B | 22 | 10 | 1.7 | 6 | 700 | 1 | 348 | 314 | 139 | 244 | 220 | 98 |
| TRJB336*010#RJ | B | 33 | 10 | 2.5 | 6 | 1000 | 1 | 292 | 262 | 117 | 292 | 262 | 117 |
| TRJB336*010#0650 | B | 33 | 10 | 2.5 | 6 | 650 | 1 | 362 | 325 | 145 | 235 | 212 | 94 |
| TRJC336*010#RJ | C | 33 | 10 | 2.5 | 6 | 590 | 1 | 432 | 389 | 173 | 255 | 229 | 102 |
| TRJC336*010#0300 | C | 33 | 10 | 2.5 | 6 | 300 | 1 | 606 | 545 | 242 | 182 | 163 | 73 |
| TRJD336*010#RJ | D | 33 | 10 | 2.5 | 6 | 1100 | 1 | 369 | 332 | 148 | 406 | 366 | 162 |
| TRJC476*010#RJ | C | 47 | 10 | 3.5 | 6 | 540 | 1 | 451 | 406 | 181 | 244 | 219 | 97 |
| TRJC476*010#0300 | C | 47 | 10 | 3.5 | 6 | 300 | 1 | 606 | 545 | 242 | 182 | 163 | 73 |
| TRJD476*010#RJ | D | 47 | 10 | 3.5 | 6 | 400 | 1 | 612 | 551 | 245 | 245 | 220 | 98 |
| TRJC686*010#RJ | C | 68 | 10 | 5.1 | 6 | 490 | 1 | 474 | 426 | 190 | 232 | 209 | 93 |
| TRJC686*010#0300 | C | 68 | 10 | 5.1 | 6 | 300 | 1 | 606 | 545 | 242 | 182 | 163 | 73 |
| TRJC107*010#RJ | C | 100 | 10 | 7.5 | 8 | 500 | 1 | 469 | 422 | 188 | 235 | 211 | 94 |
| TRJC107*010#0200 | C | 100 | 10 | 7.5 | 8 | 200 | 1 | 742 | 667 | 297 | 148 | 133 | 59 |
| TRJD107*010#RJ | D | 100 | 10 | 7.5 | 6 | 440 | 1 | 584 | 525 | 234 | 257 | 231 | 103 |
| TRJD107*010#0100 | D | 100 | 10 | 7.5 | 6 | 100 | 1 | 1225 | 1102 | 490 | 122 | 110 | 49 |
| TRJD107*010#0150 | D | 100 | 10 | 7.5 | 6 | 150 | 1 | 1000 | 900 | 400 | 150 | 135 | 60 |

¹⁾ Dry pack option (see How to order) recommended for reduction of stress during soldering. Dry pack parts should be treated as MSL 3.
 Moisture Sensitivity Level (MSL) is defined according to J-STD-020.
 All technical data relates to an ambient temperature of +25°C. Capacitance and DF are measured at 120Hz, 0.5V RMS with a maximum DC bias of 2.2 volts.
 DCL is measured at rated voltage after 5 minutes.

The EIA & CECC standards for low ESR Solid Tantalum Capacitors allow an ESR movement to 1.25 times catalogue limit post mounting.
 For typical weight and composition see page 144.

NOTE: AVX reserves the right to supply a higher voltage rating or tighter tolerance part in the same case size, to the same reliability standards.



TRJ Series



Professional Tantalum Chip Capacitor

RATINGS & PART NUMBER REFERENCE

| AVX Part No. | Case Size | Capacitance (µF) | Rated Voltage (V) | DCL (µA) Max. | DF % Max. | ESR Max. (mΩ) @100kHz | MSL | 100kHz RMS Current (mA) | | | 100kHz RMS Voltage (mV) | | |
|---|-----------|------------------|-------------------|---------------|-----------|-----------------------|-----------------|-------------------------|------|-------|-------------------------|------|-------|
| | | | | | | | | 25°C | 85°C | 125°C | 25°C | 85°C | 125°C |
| TRJE107*010#RJ | E | 100 | 10 | 7.5 | 6 | 440 | 1 ¹⁾ | 612 | 551 | 245 | 269 | 242 | 108 |
| TRJE107*010#0100 | E | 100 | 10 | 7.5 | 6 | 100 | 1 ¹⁾ | 1285 | 1156 | 514 | 128 | 116 | 51 |
| TRJD157*010#RJ | D | 150 | 10 | 11 | 8 | 400 | 1 | 612 | 551 | 245 | 245 | 220 | 98 |
| TRJD157*010#0150 | D | 150 | 10 | 11 | 8 | 150 | 1 | 1000 | 900 | 400 | 150 | 135 | 60 |
| TRJE157*010#RJ | E | 150 | 10 | 11 | 8 | 400 | 1 ¹⁾ | 642 | 578 | 257 | 257 | 231 | 103 |
| TRJE157*010#0150 | E | 150 | 10 | 11 | 8 | 150 | 1 ¹⁾ | 1049 | 944 | 420 | 157 | 142 | 63 |
| TRJD227*010#RJ | D | 220 | 10 | 17 | 8 | 500 | 1 | 548 | 493 | 219 | 274 | 246 | 110 |
| TRJE227*010#RJ | E | 220 | 10 | 17 | 8 | 360 | 1 ¹⁾ | 677 | 609 | 271 | 244 | 219 | 97 |
| TRJE227*010#0150 | E | 220 | 10 | 17 | 8 | 150 | 1 ¹⁾ | 1049 | 944 | 420 | 157 | 142 | 63 |
| TRJE337*010#RJ | E | 330 | 10 | 25 | 8 | 300 | 1 ¹⁾ | 742 | 667 | 297 | 222 | 200 | 89 |
| TRJE337*010#100 | E | 330 | 10 | 25 | 8 | 10.0 | 1 ¹⁾ | 1285 | 1156 | 514 | 128 | 116 | 51 |
| 16 Volt @ 85°C (10 Volt @ 125°C) | | | | | | | | | | | | | |
| TRJA105*016#RJ | A | 1.0 | 16 | 0.30 | 6 | 10000 | 1 | 87 | 78 | 35 | 866 | 779 | 346 |
| TRJA225*016#RJ | A | 2.2 | 16 | 0.30 | 6 | 4550 | 1 | 128 | 116 | 51 | 584 | 526 | 234 |
| TRJA225*016#3500 | A | 2.2 | 16 | 0.30 | 6 | 3500 | 1 | 146 | 132 | 59 | 512 | 461 | 205 |
| TRJA335*016#RJ | A | 3.3 | 16 | 0.40 | 6 | 3740 | 1 | 142 | 127 | 57 | 530 | 477 | 212 |
| TRJA335*016#3500 | A | 3.3 | 16 | 0.40 | 6 | 3500 | 1 | 146 | 132 | 59 | 512 | 461 | 205 |
| TRJB335*016#RJ | B | 3.3 | 16 | 0.40 | 6 | 4500 | 1 | 137 | 124 | 55 | 618 | 557 | 247 |
| TRJA475*016#RJ | A | 4.7 | 16 | 0.56 | 6 | 3160 | 1 | 154 | 139 | 62 | 487 | 438 | 195 |
| TRJA475*016#2000 | A | 4.7 | 16 | 0.56 | 6 | 2000 | 1 | 194 | 174 | 77 | 387 | 349 | 155 |
| TRJB475*016#RJ | B | 4.7 | 16 | 0.56 | 6 | 3160 | 1 | 164 | 148 | 66 | 518 | 466 | 207 |
| TRJB475*016#1500 | B | 4.7 | 16 | 0.56 | 6 | 1500 | 1 | 238 | 214 | 95 | 357 | 321 | 143 |
| TRJA685*016#RJ | A | 6.8 | 16 | 0.82 | 4 | 2000 | 1 | 194 | 174 | 77 | 387 | 349 | 155 |
| TRJA685*016#1500 | A | 6.8 | 16 | 0.82 | 4 | 1500 | 1 | 224 | 201 | 89 | 335 | 302 | 134 |
| TRJB685*016#RJ | B | 6.8 | 16 | 0.82 | 6 | 2650 | 1 | 179 | 161 | 72 | 475 | 427 | 190 |
| TRJB685*016#1200 | B | 6.8 | 16 | 0.82 | 6 | 1200 | 1 | 266 | 240 | 106 | 319 | 287 | 128 |
| TRJC685*016#RJ | C | 6.8 | 16 | 0.82 | 6 | 2500 | 1 | 210 | 189 | 84 | 524 | 472 | 210 |
| TRJB106*016#RJ | B | 10 | 16 | 1.2 | 6 | 2200 | 1 | 197 | 177 | 79 | 432 | 389 | 173 |
| TRJB106*016#0800 | B | 10 | 16 | 1.2 | 6 | 800 | 1 | 326 | 293 | 130 | 261 | 235 | 104 |
| TRJC106*016#RJ | C | 10 | 16 | 1.2 | 6 | 2000 | 1 | 235 | 211 | 94 | 469 | 422 | 188 |
| TRJB156*016#RJ | B | 15 | 16 | 1.8 | 6 | 2030 | 1 | 205 | 184 | 82 | 415 | 374 | 166 |
| TRJB156*016#0800 | B | 15 | 16 | 1.8 | 6 | 800 | 1 | 326 | 293 | 130 | 261 | 235 | 104 |
| TRJB226*016#RJ | B | 22 | 16 | 2.6 | 6 | 1100 | 1 | 278 | 250 | 111 | 306 | 275 | 122 |
| TRJB226*016#0600 | B | 22 | 16 | 2.6 | 6 | 600 | 1 | 376 | 339 | 151 | 226 | 203 | 90 |
| TRJC226*016#RJ | C | 22 | 16 | 2.6 | 6 | 700 | 1 | 396 | 357 | 159 | 277 | 250 | 111 |
| TRJC226*016#0350 | C | 22 | 16 | 2.6 | 6 | 350 | 1 | 561 | 505 | 224 | 196 | 177 | 78 |
| TRJD226*016#RJ | D | 22 | 16 | 2.6 | 6 | 1100 | 1 | 369 | 332 | 148 | 406 | 366 | 162 |
| TRJC336*016#RJ | C | 33 | 16 | 4.0 | 6 | 590 | 1 | 432 | 389 | 173 | 255 | 229 | 102 |
| TRJC336*016#0300 | C | 33 | 16 | 4.0 | 6 | 300 | 1 | 606 | 545 | 242 | 182 | 163 | 73 |
| TRJC476*016#RJ | C | 47 | 16 | 5.6 | 6 | 540 | 1 | 451 | 406 | 181 | 244 | 219 | 97 |
| TRJC476*016#0350 | C | 47 | 16 | 5.6 | 6 | 350 | 1 | 561 | 505 | 224 | 196 | 177 | 78 |
| TRJD476*016#RJ | D | 47 | 16 | 5.6 | 6 | 540 | 1 | 527 | 474 | 211 | 285 | 256 | 114 |
| TRJD476*016#0200 | D | 47 | 16 | 5.6 | 6 | 200 | 1 | 866 | 779 | 346 | 173 | 156 | 69 |
| TRJC686*016#RJ | C | 68 | 16 | 8.2 | 6 | 490 | 1 | 474 | 426 | 190 | 232 | 209 | 93 |
| TRJC686*016#0200 | C | 68 | 16 | 8.2 | 6 | 200 | 1 | 742 | 667 | 297 | 148 | 133 | 59 |
| TRJD686*016#RJ | D | 68 | 16 | 8.2 | 6 | 490 | 1 | 553 | 498 | 221 | 271 | 244 | 108 |
| TRJD686*016#0150 | D | 68 | 16 | 8.2 | 6 | 150 | 1 | 1000 | 900 | 400 | 150 | 135 | 60 |
| TRJD107*016#RJ | D | 100 | 16 | 12 | 6 | 440 | 1 | 584 | 525 | 234 | 257 | 231 | 103 |
| TRJD107*016#0150 | D | 100 | 16 | 12 | 6 | 150 | 1 | 1000 | 900 | 400 | 150 | 135 | 60 |
| TRJE107*016#RJ | E | 100 | 16 | 12 | 6 | 440 | 1 ¹⁾ | 612 | 551 | 245 | 269 | 242 | 108 |
| TRJE107*016#0150 | E | 100 | 16 | 12 | 6 | 150 | 1 ¹⁾ | 1049 | 944 | 420 | 157 | 142 | 63 |
| TRJE157*016#RJ | E | 150 | 16 | 16 | 6 | 300 | 1 ¹⁾ | 742 | 667 | 297 | 222 | 200 | 89 |
| TRJE157*016#0150 | E | 150 | 16 | 16 | 6 | 150 | 1 ¹⁾ | 1049 | 944 | 420 | 157 | 142 | 63 |
| TRJU227*016#RJ | U | 220 | 16 | 26.4 | 12 | 500 | 3 | 574 | 517 | 230 | 287 | 259 | 115 |
| TRJU227*016#R0200V | U | 220 | 16 | 26.4 | 12 | 200 | 3 | 908 | 817 | 363 | 182 | 163 | 73 |
| 20 Volt @ 85°C (13 Volt @ 125°C) | | | | | | | | | | | | | |
| TRJA105*020#RJ | A | 1 | 20 | 0.30 | 4 | 6630 | 1 | 106 | 96 | 43 | 705 | 635 | 282 |
| TRJA105*020#3000 | A | 1 | 20 | 0.30 | 4 | 3000 | 1 | 158 | 142 | 63 | 474 | 427 | 190 |
| TRJA155*020#RJ | A | 1.5 | 20 | 0.30 | 6 | 5460 | 1 | 117 | 105 | 47 | 640 | 576 | 256 |
| TRJA155*020#3000 | A | 1.5 | 20 | 0.30 | 6 | 3000 | 1 | 158 | 142 | 63 | 474 | 427 | 190 |
| TRJA225*020#RJ | A | 2.2 | 20 | 0.33 | 6 | 4550 | 1 | 128 | 116 | 51 | 584 | 526 | 234 |
| TRJA225*020#3000 | A | 2.2 | 20 | 0.33 | 6 | 3000 | 1 | 158 | 142 | 63 | 474 | 427 | 190 |
| TRJA335*020#RJ | A | 3.3 | 20 | 0.50 | 6 | 3740 | 1 | 142 | 127 | 57 | 530 | 477 | 212 |
| TRJA335*020#2500 | A | 3.3 | 20 | 0.50 | 6 | 2500 | 1 | 173 | 156 | 69 | 433 | 390 | 173 |
| TRJB335*020#RJ | B | 3.3 | 20 | 0.50 | 6 | 3740 | 1 | 151 | 136 | 60 | 564 | 507 | 226 |
| TRJB335*020#1300 | B | 3.3 | 20 | 0.50 | 6 | 1300 | 1 | 256 | 230 | 102 | 332 | 299 | 133 |
| TRJA475*020#RJ | A | 4.7 | 20 | 0.71 | 5 | 2500 | 1 | 184 | 166 | 74 | 461 | 415 | 184 |
| TRJA475*020#1800 | A | 4.7 | 20 | 0.71 | 5 | 1800 | 1 | 217 | 196 | 87 | 391 | 352 | 156 |
| TRJB475*020#RJ | B | 4.7 | 20 | 0.71 | 6 | 3160 | 1 | 164 | 148 | 66 | 518 | 466 | 207 |
| TRJB475*020#1000 | B | 4.7 | 20 | 0.71 | 6 | 1000 | 1 | 292 | 262 | 117 | 292 | 262 | 117 |
| TRJB685*020#RJ | B | 6.8 | 20 | 1.0 | 6 | 2650 | 1 | 179 | 161 | 72 | 475 | 427 | 190 |

¹⁾ Dry pack option (see How to order) recommended for reduction of stress during soldering. Dry pack parts should be treated as MSL 3.
Moisture Sensitivity Level (MSL) is defined according to J-STD-020.
All technical data relates to an ambient temperature of +25°C. Capacitance and DF are measured at 120Hz, 0.5V RMS with a maximum DC bias of 2.2 volts.
DCL is measured at rated voltage after 5 minutes.

The EIA & CECC standards for low ESR Solid Tantalum Capacitors allow an ESR movement to 1.25 times catalogue limit post mounting.

For typical weight and composition see page 144.

NOTE: AVX reserves the right to supply a higher voltage rating or tighter tolerance part in the same case size, to the same reliability standards.



TRJ Series

Professional Tantalum Chip Capacitor



RATINGS & PART NUMBER REFERENCE

| AVX Part No. | Case Size | Capacitance (μF) | Rated Voltage (V) | DCL (μA) Max. | DF % Max. | ESR Max. (mΩ) @100kHz | MSL | 100kHz RMS Current (mA) | | | 100kHz RMS Voltage (mV) | | |
|---|-----------|------------------|-------------------|---------------|-----------|-----------------------|-----------------|-------------------------|------|-------|-------------------------|------|-------|
| | | | | | | | | 25°C | 85°C | 125°C | 25°C | 85°C | 125°C |
| TRJB685*020#1000 | B | 6.8 | 20 | 1.0 | 6 | 1000 | 1 | 292 | 262 | 117 | 292 | 262 | 117 |
| TRJC685*020#RJ | C | 6.8 | 20 | 1.0 | 6 | 2000 | 1 | 235 | 211 | 94 | 469 | 422 | 188 |
| TRJB106*020#RJ | B | 10 | 20 | 1.5 | 6 | 2200 | 1 | 197 | 177 | 79 | 432 | 389 | 173 |
| TRJB106*020#1000 | B | 10 | 20 | 1.5 | 6 | 1000 | 1 | 292 | 262 | 117 | 292 | 262 | 117 |
| TRJC106*020#RJ | C | 10 | 20 | 1.5 | 6 | 800 | 1 | 371 | 334 | 148 | 297 | 267 | 119 |
| TRJC106*020#0500 | C | 10 | 20 | 1.5 | 6 | 500 | 1 | 469 | 422 | 188 | 235 | 211 | 94 |
| TRJB156*020#RJ | B | 15 | 20 | 2.3 | 6 | 1400 | 1 | 280 | 252 | 112 | 392 | 353 | 157 |
| TRJB156*020#0500 | B | 15 | 20 | 2.3 | 6 | 500 | 1 | 469 | 422 | 188 | 235 | 211 | 94 |
| TRJC156*020#RJ | C | 15 | 20 | 2.3 | 6 | 720 | 1 | 391 | 352 | 156 | 281 | 253 | 113 |
| TRJC156*020#0400 | C | 15 | 20 | 2.3 | 6 | 400 | 1 | 524 | 472 | 210 | 210 | 189 | 84 |
| TRJD156*020#RJ | D | 15 | 20 | 2.3 | 6 | 1100 | 1 | 369 | 332 | 148 | 406 | 366 | 162 |
| TRJC226*020#RJ | C | 22 | 20 | 3.3 | 6 | 650 | 1 | 411 | 370 | 165 | 267 | 241 | 107 |
| TRJC226*020#0400 | C | 22 | 20 | 3.3 | 6 | 400 | 1 | 524 | 472 | 210 | 210 | 189 | 84 |
| TRJD226*020#RJ | D | 22 | 20 | 3.3 | 6 | 650 | 1 | 480 | 432 | 192 | 312 | 281 | 125 |
| TRJD226*020#0150 | D | 22 | 20 | 3.3 | 6 | 150 | 1 | 1000 | 900 | 400 | 150 | 135 | 60 |
| TRJD226*020#0300 | D | 22 | 20 | 3.3 | 6 | 300 | 1 | 707 | 636 | 283 | 212 | 191 | 85 |
| TRJC336*020#RJ | C | 33 | 20 | 5.0 | 6 | 590 | 1 | 432 | 389 | 173 | 255 | 229 | 102 |
| TRJC336*020#0300 | C | 33 | 20 | 5.0 | 6 | 300 | 1 | 606 | 545 | 242 | 182 | 163 | 73 |
| TRJD336*020#RJ | D | 33 | 20 | 5.0 | 6 | 590 | 1 | 504 | 454 | 202 | 297 | 268 | 119 |
| TRJD336*020#0250 | D | 33 | 20 | 5.0 | 6 | 250 | 1 | 775 | 697 | 310 | 194 | 174 | 77 |
| TRJD476*020#RJ | D | 47 | 20 | 7.1 | 6 | 540 | 1 | 527 | 474 | 211 | 285 | 256 | 114 |
| TRJD476*020#0200 | D | 47 | 20 | 7.1 | 6 | 200 | 1 | 866 | 779 | 346 | 173 | 156 | 69 |
| TRJD686*020#RJ | D | 68 | 20 | 10 | 6 | 490 | 1 | 553 | 498 | 221 | 271 | 244 | 108 |
| TRJD686*020#0200 | D | 68 | 20 | 10 | 6 | 200 | 1 | 866 | 779 | 346 | 173 | 156 | 69 |
| TRJE686*020#RJ | E | 68 | 20 | 10 | 6 | 490 | 1 ¹⁾ | 580 | 522 | 232 | 284 | 256 | 114 |
| TRJE686*020#0120 | E | 68 | 20 | 10 | 6 | 120 | 1 ¹⁾ | 1173 | 1055 | 469 | 141 | 127 | 56 |
| TRJE686*020#0200 | E | 68 | 20 | 10 | 6 | 200 | 1 ¹⁾ | 908 | 817 | 363 | 182 | 163 | 73 |
| TRJE107*020#RJ | E | 100 | 20 | 15 | 6 | 300 | 1 ¹⁾ | 742 | 667 | 297 | 222 | 200 | 89 |
| TRJE107*020#0150 | E | 100 | 20 | 15 | 6 | 150 | 1 ¹⁾ | 1049 | 944 | 420 | 157 | 142 | 63 |
| 25 Volt @ 85°C (17 Volt @ 125°C) | | | | | | | | | | | | | |
| TRJA474*025#RJ | A | 0.47 | 25 | 0.30 | 4 | 9530 | 1 | 89 | 80 | 35 | 845 | 761 | 338 |
| TRJA474*025#7000 | A | 0.47 | 25 | 0.30 | 4 | 7000 | 1 | 104 | 93 | 41 | 725 | 652 | 290 |
| TRJA684*025#RJ | A | 0.68 | 25 | 0.30 | 4 | 7980 | 1 | 97 | 87 | 39 | 774 | 696 | 309 |
| TRJA684*025#6000 | A | 0.68 | 25 | 0.30 | 4 | 6000 | 1 | 112 | 101 | 45 | 671 | 604 | 268 |
| TRJA105*025#RJ | A | 1 | 25 | 0.30 | 4 | 6630 | 1 | 106 | 96 | 43 | 705 | 635 | 282 |
| TRJA105*025#3000 | A | 1 | 25 | 0.30 | 4 | 3000 | 1 | 158 | 142 | 63 | 474 | 427 | 190 |
| TRJA155*025#RJ | A | 1.5 | 25 | 0.30 | 6 | 5460 | 1 | 117 | 105 | 47 | 640 | 576 | 256 |
| TRJA155*025#3000 | A | 1.5 | 25 | 0.30 | 6 | 3000 | 1 | 158 | 142 | 63 | 474 | 427 | 190 |
| TRJB155*025#RJ | B | 1.5 | 25 | 0.30 | 6 | 5000 | 1 | 130 | 117 | 52 | 652 | 587 | 261 |
| TRJA225*025#RJ | A | 2.2 | 25 | 0.41 | 6 | 2900 | 1 | 161 | 145 | 64 | 466 | 420 | 187 |
| TRJA225*025#1600 | A | 2.2 | 25 | 0.41 | 6 | 1600 | 1 | 217 | 195 | 87 | 346 | 312 | 139 |
| TRJB225*025#RJ | B | 2.2 | 25 | 0.41 | 6 | 4550 | 1 | 137 | 123 | 55 | 622 | 560 | 249 |
| TRJB225*025#1200 | B | 2.2 | 25 | 0.41 | 6 | 1200 | 1 | 266 | 240 | 106 | 319 | 287 | 128 |
| TRJB335*025#RJ | B | 3.3 | 25 | 0.62 | 6 | 3740 | 1 | 151 | 136 | 60 | 564 | 507 | 226 |
| TRJB335*025#2000 | B | 3.3 | 25 | 0.62 | 6 | 2000 | 1 | 206 | 186 | 82 | 412 | 371 | 165 |
| TRJB475*025#RJ | B | 4.7 | 25 | 0.88 | 6 | 3160 | 1 | 164 | 148 | 66 | 518 | 466 | 207 |
| TRJB475*025#1000 | B | 4.7 | 25 | 0.88 | 6 | 1000 | 1 | 292 | 262 | 117 | 292 | 262 | 117 |
| TRJB685*025#RJ | B | 6.8 | 25 | 1.30 | 6 | 1500 | 1 | 238 | 214 | 95 | 357 | 321 | 143 |
| TRJB685*025#1000 | B | 6.8 | 25 | 1.30 | 6 | 1000 | 1 | 292 | 262 | 117 | 292 | 262 | 117 |
| TRJC685*025#RJ | C | 6.8 | 25 | 1.3 | 6 | 1070 | 1 | 321 | 289 | 128 | 343 | 309 | 137 |
| TRJC685*025#0600 | C | 6.8 | 25 | 1.3 | 6 | 600 | 1 | 428 | 385 | 171 | 257 | 231 | 103 |
| TRJC106*025#RJ | C | 10 | 25 | 1.9 | 6 | 800 | 1 | 371 | 334 | 148 | 297 | 267 | 119 |
| TRJC106*025#0600 | C | 10 | 25 | 1.9 | 6 | 600 | 1 | 428 | 385 | 171 | 257 | 231 | 103 |
| TRJD106*025#RJ | D | 10 | 25 | 1.9 | 6 | 1200 | 1 | 354 | 318 | 141 | 424 | 382 | 170 |
| TRJC156*025#RJ | C | 15 | 25 | 2.8 | 6 | 720 | 1 | 391 | 352 | 156 | 281 | 253 | 113 |
| TRJC156*025#0500 | C | 15 | 25 | 2.8 | 6 | 500 | 1 | 469 | 422 | 188 | 235 | 211 | 94 |
| TRJD156*025#RJ | D | 15 | 25 | 2.8 | 6 | 720 | 1 | 456 | 411 | 183 | 329 | 296 | 131 |
| TRJD156*025#0300 | D | 15 | 25 | 2.8 | 6 | 300 | 1 | 707 | 636 | 283 | 212 | 191 | 85 |
| TRJD226*025#RJ | D | 22 | 25 | 4.1 | 6 | 650 | 1 | 480 | 432 | 192 | 312 | 281 | 125 |
| TRJD226*025#0300 | D | 22 | 25 | 4.1 | 6 | 300 | 1 | 707 | 636 | 283 | 212 | 191 | 85 |
| TRJD336*025#RJ | D | 33 | 25 | 6.2 | 6 | 590 | 1 | 504 | 454 | 202 | 297 | 268 | 119 |
| TRJD336*025#0400 | D | 33 | 25 | 6.2 | 6 | 400 | 1 | 612 | 551 | 245 | 245 | 220 | 98 |
| TRJD476*025#RJ | D | 47 | 25 | 8.8 | 6 | 540 | 1 | 527 | 474 | 211 | 285 | 256 | 114 |
| TRJD476*025#0250 | D | 47 | 25 | 8.8 | 6 | 250 | 1 | 775 | 697 | 310 | 194 | 174 | 77 |
| TRJE476*025#RJ | E | 47 | 25 | 8.8 | 6 | 540 | 1 ¹⁾ | 553 | 497 | 221 | 298 | 269 | 119 |
| TRJE476*025#0150 | E | 47 | 25 | 8.8 | 6 | 150 | 1 ¹⁾ | 1049 | 944 | 420 | 157 | 142 | 63 |
| 35 Volt @ 85°C (23 Volt @ 125°C) | | | | | | | | | | | | | |
| TRJA104*035#RJ | A | 0.1 | 35 | 0.30 | 4 | 20000 | 1 | 61 | 55 | 24 | 1225 | 1102 | 490 |
| TRJA154*035#RJ | A | 0.15 | 35 | 0.30 | 4 | 16470 | 1 | 67 | 61 | 27 | 1111 | 1000 | 445 |
| TRJA154*035#6000 | A | 0.15 | 35 | 0.30 | 4 | 6000 | 1 | 112 | 101 | 45 | 671 | 604 | 268 |
| TRJA224*035#RJ | A | 0.22 | 35 | 0.30 | 4 | 13710 | 1 | 74 | 67 | 30 | 1014 | 913 | 406 |

¹⁾ Dry pack option (see How to order) recommended for reduction of stress during soldering. Dry pack parts should be treated as MSL 3.
 Moisture Sensitivity Level (MSL) is defined according to J-STD-020.
 All technical data relates to an ambient temperature of +25°C. Capacitance and DF are measured at 120Hz, 0.5V RMS with a maximum DC bias of 2.2 volts.
 DCL is measured at rated voltage after 5 minutes.

The EIA & CECC standards for low ESR Solid Tantalum Capacitors allow an ESR movement to 1.25 times catalogue limit post mounting.
 For typical weight and composition see page 144.
NOTE: AVX reserves the right to supply a higher voltage rating or tighter tolerance part in the same case size, to the same reliability standards.



TRJ Series



Professional Tantalum Chip Capacitor

RATINGS & PART NUMBER REFERENCE

| AVX Part No. | Case Size | Capacitance (µF) | Rated Voltage (V) | DCL (µA) Max. | DF % Max. | ESR Max. (mΩ) @100kHz | MSL | 100kHz RMS Current (mA) | | | 100kHz RMS Voltage (mV) | | |
|---|-----------|------------------|-------------------|---------------|-----------|-----------------------|-----------------|-------------------------|------|-------|-------------------------|------|-------|
| | | | | | | | | 25°C | 85°C | 125°C | 25°C | 85°C | 125°C |
| TRJA224*035#6000 | A | 0.22 | 35 | 0.30 | 4 | 6000 | 1 | 112 | 101 | 45 | 671 | 604 | 268 |
| TRJA334*035#RJ | A | 0.33 | 35 | 0.30 | 4 | 11280 | 1 | 82 | 73 | 33 | 920 | 828 | 368 |
| TRJA334*035#6000 | A | 0.33 | 35 | 0.30 | 4 | 6000 | 1 | 112 | 101 | 45 | 671 | 604 | 268 |
| TRJA474*035#RJ | A | 0.47 | 35 | 0.30 | 4 | 9530 | 1 | 89 | 80 | 35 | 845 | 761 | 338 |
| TRJA474*035#4000 | A | 0.47 | 35 | 0.30 | 4 | 4000 | 1 | 137 | 123 | 55 | 548 | 493 | 219 |
| TRJA684*035#RJ | A | 0.68 | 35 | 0.30 | 4 | 7980 | 1 | 97 | 87 | 39 | 774 | 696 | 309 |
| TRJA684*035#6000 | A | 0.68 | 35 | 0.30 | 4 | 6000 | 1 | 112 | 101 | 45 | 671 | 604 | 268 |
| TRJA105*035#RJ | A | 1 | 35 | 0.30 | 4 | 6630 | 1 | 106 | 96 | 43 | 705 | 635 | 282 |
| TRJA105*035#3000 | A | 1 | 35 | 0.30 | 4 | 3000 | 1 | 158 | 142 | 63 | 474 | 427 | 190 |
| TRJB105*035#RJ | B | 1 | 35 | 0.30 | 4 | 3400 | 1 | 158 | 142 | 63 | 538 | 484 | 215 |
| TRJB105*035#2000 | B | 1 | 35 | 0.30 | 4 | 2000 | 1 | 206 | 186 | 82 | 412 | 371 | 165 |
| TRJA155*035#RJ | A | 1.5 | 35 | 0.39 | 6 | 3100 | 1 | 166 | 149 | 66 | 513 | 462 | 205 |
| TRJA155*035#2000 | A | 1.5 | 35 | 0.39 | 6 | 2000 | 1 | 206 | 186 | 82 | 412 | 371 | 165 |
| TRJB155*035#RJ | B | 1.5 | 35 | 0.39 | 6 | 5460 | 1 | 125 | 112 | 50 | 681 | 613 | 272 |
| TRJB155*035#2500 | B | 1.5 | 35 | 0.39 | 6 | 2500 | 1 | 184 | 166 | 74 | 461 | 415 | 184 |
| TRJB225*035#RJ | B | 2.2 | 35 | 0.58 | 6 | 4550 | 1 | 137 | 123 | 55 | 622 | 560 | 249 |
| TRJB225*035#2000 | B | 2.2 | 35 | 0.58 | 6 | 2000 | 1 | 206 | 186 | 82 | 412 | 371 | 165 |
| TRJB335*035#RJ | B | 3.3 | 35 | 0.87 | 6 | 3740 | 1 | 151 | 136 | 60 | 564 | 507 | 226 |
| TRJB335*035#1000 | B | 3.3 | 35 | 0.87 | 6 | 1000 | 1 | 292 | 262 | 117 | 292 | 262 | 117 |
| TRJC335*035#RJ | C | 3.3 | 35 | 0.87 | 6 | 1840 | 1 | 245 | 220 | 98 | 450 | 405 | 180 |
| TRJC335*035#0800 | C | 3.3 | 35 | 0.87 | 6 | 800 | 1 | 371 | 334 | 148 | 297 | 267 | 119 |
| TRJD335*035#RJ | D | 3.3 | 35 | 0.87 | 6 | 2000 | 1 | 274 | 246 | 110 | 548 | 493 | 219 |
| TRJB475*035#RJ | B | 4.7 | 35 | 1.20 | 6 | 2200 | 1 | 224 | 201 | 89 | 492 | 443 | 197 |
| TRJB475*035#1500 | B | 4.7 | 35 | 1.20 | 6 | 1500 | 1 | 271 | 244 | 108 | 406 | 366 | 162 |
| TRJC475*035#RJ | C | 4.7 | 35 | 1.2 | 6 | 1410 | 1 | 279 | 251 | 112 | 394 | 354 | 158 |
| TRJC475*035#0600 | C | 4.7 | 35 | 1.2 | 6 | 600 | 1 | 428 | 385 | 171 | 257 | 231 | 103 |
| TRJD475*035#RJ | D | 4.7 | 35 | 1.2 | 6 | 1500 | 1 | 316 | 285 | 126 | 474 | 427 | 190 |
| TRJC685*035#RJ | C | 6.8 | 35 | 1.8 | 6 | 1070 | 1 | 321 | 289 | 128 | 343 | 309 | 137 |
| TRJC685*035#0600 | C | 6.8 | 35 | 1.8 | 6 | 600 | 1 | 428 | 385 | 171 | 257 | 231 | 103 |
| TRJD685*035#RJ | D | 6.8 | 35 | 1.8 | 6 | 1300 | 1 | 340 | 306 | 136 | 442 | 397 | 177 |
| TRJC106*035#RJ | C | 10 | 35 | 2.6 | 6 | 800 | 1 | 371 | 334 | 148 | 297 | 267 | 119 |
| TRJC106*035#0600 | C | 10 | 35 | 2.6 | 6 | 600 | 1 | 428 | 385 | 171 | 257 | 231 | 103 |
| TRJD106*035#RJ | D | 10 | 35 | 2.6 | 6 | 800 | 1 | 433 | 390 | 173 | 346 | 312 | 139 |
| TRJD106*035#0250 | D | 10 | 35 | 2.6 | 6 | 250 | 1 | 775 | 697 | 310 | 194 | 174 | 77 |
| TRJD106*035#0400 | D | 10 | 35 | 2.6 | 6 | 400 | 1 | 612 | 551 | 245 | 245 | 220 | 98 |
| TRJD156*035#RJ | D | 15 | 35 | 3.9 | 6 | 720 | 1 | 456 | 411 | 183 | 329 | 296 | 131 |
| TRJD156*035#0225 | D | 15 | 35 | 3.9 | 6 | 225 | 1 | 816 | 735 | 327 | 184 | 165 | 73 |
| TRJD226*035#RJ | D | 22 | 35 | 5.8 | 6 | 650 | 1 | 480 | 432 | 192 | 312 | 281 | 125 |
| TRJD226*035#0200 | D | 22 | 35 | 5.8 | 6 | 200 | 1 | 866 | 779 | 346 | 173 | 156 | 69 |
| TRJD226*035#0400 | D | 22 | 35 | 5.8 | 6 | 400 | 1 | 612 | 551 | 245 | 245 | 220 | 98 |
| TRJE336*035#RJ | E | 33 | 35 | 8.7 | 6 | 590 | 1 ¹⁾ | 529 | 476 | 212 | 312 | 281 | 125 |
| TRJE336*035#0150 | E | 33 | 35 | 8.7 | 6 | 150 | 1 ¹⁾ | 1049 | 944 | 420 | 157 | 142 | 63 |
| TRJE336*035#0250 | E | 33 | 35 | 8.7 | 6 | 250 | 1 ¹⁾ | 812 | 731 | 325 | 203 | 183 | 81 |
| 50 Volt @ 85°C (33 Volt @ 125°C) | | | | | | | | | | | | | |
| TRJA224*050#RJ | A | 0.22 | 50 | 0.3 | 4 | 7500 | 1 | 100 | 90 | 40 | 750 | 675 | 300 |
| TRJA224*050#7000 | A | 0.22 | 50 | 0.3 | 4 | 7000 | 1 | 104 | 93 | 41 | 725 | 652 | 290 |
| TRJA334*050#RJ | A | 0.33 | 50 | 0.3 | 4 | 7000 | 1 | 104 | 93 | 41 | 725 | 652 | 290 |
| TRJB474*050#RJ | B | 0.47 | 50 | 0.3 | 4 | 5000 | 1 | 130 | 117 | 52 | 652 | 587 | 261 |
| TRJB684*050#RJ | B | 0.68 | 50 | 0.3 | 4 | 4000 | 1 | 146 | 131 | 58 | 583 | 525 | 233 |
| TRJB684*050#2000 | B | 0.68 | 50 | 0.3 | 4 | 2000 | 1 | 206 | 186 | 82 | 412 | 371 | 165 |
| TRJB105*050#RJ | B | 1 | 50 | 0.4 | 4 | 3400 | 1 | 158 | 142 | 63 | 538 | 484 | 215 |
| TRJB105*050#2000 | B | 1 | 50 | 0.4 | 4 | 2000 | 1 | 206 | 186 | 82 | 412 | 371 | 165 |
| TRJC105*050#RJ | C | 1 | 50 | 0.4 | 4 | 3000 | 1 | 191 | 172 | 77 | 574 | 517 | 230 |
| TRJC155*050#RJ | C | 1.5 | 50 | 0.6 | 6 | 2500 | 1 | 210 | 189 | 84 | 524 | 472 | 210 |
| TRJC155*050#1500 | C | 1.5 | 50 | 0.6 | 6 | 1500 | 1 | 271 | 244 | 108 | 406 | 366 | 162 |
| TRJC225*050#RJ | C | 2.2 | 50 | 0.8 | 6 | 1700 | 1 | 254 | 229 | 102 | 432 | 389 | 173 |
| TRJC225*050#1000 | C | 2.2 | 50 | 0.8 | 6 | 1000 | 1 | 332 | 298 | 133 | 332 | 298 | 133 |
| TRJD225*050#RJ | D | 2.2 | 50 | 0.8 | 4.5 | 2000 | 1 | 274 | 246 | 110 | 548 | 493 | 219 |
| TRJD225*050#1200 | D | 2.2 | 50 | 0.8 | 4.5 | 1200 | 1 | 354 | 318 | 141 | 424 | 382 | 170 |
| TRJC335*050#RJ | C | 3.3 | 50 | 1.2 | 6 | 1400 | 1 | 280 | 252 | 112 | 392 | 353 | 157 |
| TRJC335*050#1000 | C | 3.3 | 50 | 1.2 | 6 | 1000 | 1 | 332 | 298 | 133 | 332 | 298 | 133 |
| TRJD335*050#RJ | D | 3.3 | 50 | 1.20 | 4.5 | 1100 | 1 | 369 | 332 | 148 | 406 | 366 | 162 |
| TRJD335*050#0800 | D | 3.3 | 50 | 1.20 | 4.5 | 800 | 1 | 433 | 390 | 173 | 346 | 312 | 139 |
| TRJD475*050#RJ | D | 4.7 | 50 | 1.80 | 4.5 | 900 | 1 | 408 | 367 | 163 | 367 | 331 | 147 |
| TRJD475*050#0600 | D | 4.7 | 50 | 1.80 | 4.5 | 600 | 1 | 500 | 450 | 200 | 300 | 270 | 120 |
| TRJD685*050#RJ | D | 6.8 | 50 | 2.60 | 4.5 | 700 | 1 | 463 | 417 | 185 | 324 | 292 | 130 |
| TRJE106*050#RJ | E | 10 | 50 | 3.80 | 4.5 | 700 | 1 ¹⁾ | 486 | 437 | 194 | 340 | 306 | 136 |
| TRJE106*050#0300 | E | 10 | 50 | 3.80 | 4.5 | 300 | 1 ¹⁾ | 742 | 667 | 297 | 222 | 200 | 89 |
| TRJE106*050#0400 | E | 10 | 50 | 3.80 | 4.5 | 400 | 1 ¹⁾ | 642 | 578 | 257 | 257 | 231 | 103 |

¹⁾ Dry pack option (see How to order) recommended for reduction of stress during soldering. Dry pack parts should be treated as MSL 3.
Moisture Sensitivity Level (MSL) is defined according to J-STD-020.
All technical data relates to an ambient temperature of +25°C. Capacitance and DF are measured at 120Hz, 0.5V RMS with a maximum DC bias of 2.2 volts.
DCL is measured at rated voltage after 5 minutes.

The EIA & CECC standards for low ESR Solid Tantalum Capacitors allow an ESR movement to 1.25 times catalogue limit post mounting.
For typical weight and composition see page 144.

NOTE: AVX reserves the right to supply a higher voltage rating or tighter tolerance part in the same case size, to the same reliability standards.



F97 Series



Resin-Molded Chip, Improved Reliability J-Lead



- Compliant to the RoHS directive (2002/95/EC).
- Compliant to AEC-Q200.
- Improved reliability - FR=0.5%/1000hrs (twice better than standard)

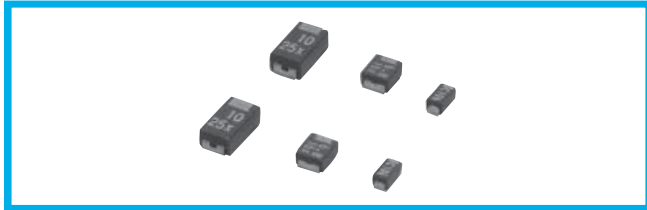

Applications

- Automotive electronics (Engine ECU)
- Industrial equipment

Type numbering system (Example: 16V 3.3μF)

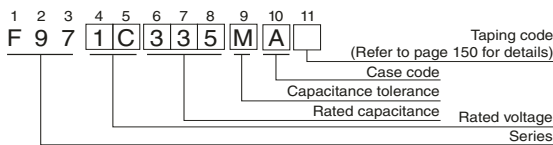

Drawing

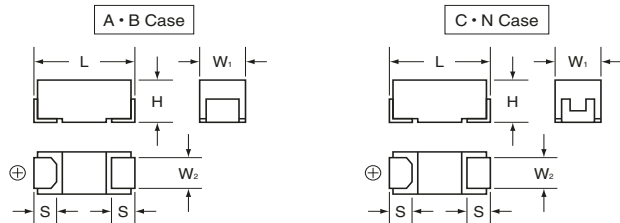

Dimensions

| Case code | L | W ₁ | W ₂ | H | S |
|-----------|-----------|----------------|----------------|-----------|-----------|
| A | 3.2 ± 0.2 | 1.6 ± 0.2 | 1.2 ± 0.1 | 1.6 ± 0.2 | 0.8 ± 0.2 |
| B | 3.5 ± 0.2 | 2.8 ± 0.2 | 2.2 ± 0.1 | 1.9 ± 0.2 | 0.8 ± 0.2 |
| C | 6.0 ± 0.2 | 3.2 ± 0.2 | 2.2 ± 0.1 | 2.5 ± 0.2 | 1.3 ± 0.2 |
| N | 7.3 ± 0.2 | 4.3 ± 0.2 | 2.4 ± 0.1 | 2.8 ± 0.2 | 1.3 ± 0.2 |

Marking

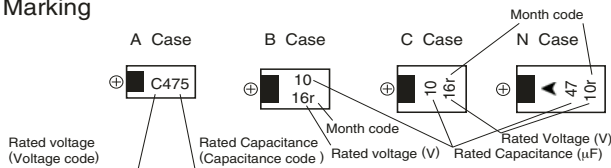

Standard ratings

| Cap. (μF) | V | 6.3 | 10 | 16 | 20 | 25 | 35 |
|-----------|------|-------|-------------|-----------|---------|---------|---------|
| 0.47 | Code | 0J | 1A | 1C | 1D | 1E | 1V |
| 0.68 | 474 | | | | A | A | A |
| 1 | 684 | | | | A | A | (A) |
| 1.5 | 105 | | | | A | A | (A) · B |
| 1.5 | 155 | | | A | A | | (A) · B |
| 2.2 | 225 | | A | A | A | (A) · B | B |
| 3.3 | 335 | A | A | A | B | | (B) · C |
| 4.7 | 475 | A | A · B | A · B | A · B | (B) · C | C |
| 6.8 | 685 | A · B | B | B | (B) · C | C | (C) · N |
| 10 | 106 | | A · B | A · B · C | (B) · C | C · N | N |
| 15 | 156 | B | B | (B) · C | N | (C) · N | |
| 22 | 226 | A · B | A · B | B · C · N | C · N | (N) | |
| 33 | 336 | A · C | B · C · N | B · C · N | | (N) | |
| 47 | 476 | B · C | (B) · C · N | (C) · N | | | |
| 68 | 686 | N | N | | | | |
| 100 | 107 | N | (C) · (N) | | | | |

Specifications

| Item | Performance Characteristics |
|-----------------------------------|---|
| Category | Temperature Range |
| | -55 to +125°C (Rated temperature : +85°C) |
| Capacitance Tolerance | ±20%, ±10% (at 120Hz) |
| Dissipation Factor | Refer to next page |
| ESR (100kHz) | Refer to next page |
| Leakage Current | <ul style="list-style-type: none"> ● After 1 minute's application of rated voltage, leakage current at 20°C is not more than 0.01CV or 0.5μA, whichever is greater. ● After 1 minute's application of rated voltage, leakage current at 85°C is not more than 0.1CV or 5μA, whichever is greater. ● After 1 minute's application of derated voltage, leakage current at 125°C is not more than 0.125CV or 6.3μA, whichever is greater. |
| Capacitance Change by Temperature | +15% Max. (at +125°C) +10% Max. (at +85°C) -10% Max. (at -55°C) |
| Damp Heat (Steady State) | At 85°C, 85% R.H., For 1000 hours (No voltage applied) Capacitance Change Within ±10% of the initial value Dissipation Factor Initial specified value or less Leakage Current 125% or less than the initial specified value |
| Load Humidity | After 500 hour's application of rated voltage in series with a 33Ω resistor at 60°C, 90 to 95% R.H., capacitors meet the characteristics requirements table below. Capacitance Change Within ±10% of the initial value Dissipation Factor Initial specified value or less Leakage Current 125% or less than the initial specified value |
| Temperature Cycles | At -55°C / +125°C, For 30 minutes each, 1000 cycles Capacitance Change Within ±10% of the initial value Dissipation Factor Initial specified value or less Leakage Current Initial specified value or less |
| Resistance to Soldering Heat | 10 seconds reflow at 260°C, 5 seconds immersion at 260°C. Capacitance Change Within ±5% of the initial value Dissipation Factor Initial specified value or less Leakage Current Initial specified value or less |
| Solderability | After immersing capacitors completely into a solder pot at 245°C for 2 to 3 seconds, more than 3/4 of their electrode area shall remain covered with new solder. |
| Surge | After application of surge in series with a 33Ω resistor at the rate of 30 seconds ON, 30 seconds OFF, for 1000 successive test cycles at 85°C, capacitors shall meet the characteristic requirements table below. Capacitance Change Within ±5% of the initial value Dissipation Factor Initial specified value or less Leakage Current Initial specified value or less |
| Endurance | After 2000 hours' application of rated voltage in series with a 3Ω resistor at 85°C, or derated voltage in series with a 3Ω resistor at 125°C, capacitors shall meet the characteristic requirements table below. Capacitance Change Within ±10% of the initial value Dissipation Factor Initial specified value or less Leakage Current Initial specified value or less |
| Shear Test | After applying the pressure load of 5N for 10 ± 1 seconds horizontally to the center of capacitor side body which has no electrode and has been soldered beforehand on a substrate, there shall be found neither exfoliation nor its sign at the terminal electrode. |
| Terminal Strength | Keeping a capacitor surface-mounted on a substrate upside down and supporting the substrate at both of the opposite bottom points 45mm apart from the center of capacitor, the pressure strength is applied with a specified jig at the center of the substrate so that substrate may bend by 1mm as illustrated. Then, there shall be found no remarkable abnormality on the capacitor terminals. |
| Failure Rate | 0.5% per 1000 hours at 85°C, V _R with 0.1Ω/V series impedance, 60% confidence level. |

() The series in parentheses are being developed.

Please contact to your local AVX sales office when these series are being designed in your application.



F97 Series



Resin-Molded Chip, Improved Reliability J-Lead

■ Standard Ratings

| Rated Volt | Rated Capacitance (μF) | Case code | Part Number | Leakage Current (μA) | Dissipation Factor (%@120Hz) | ESR (Ω@100kHz) |
|------------|------------------------|-------------|-------------|----------------------|------------------------------|----------------|
| 6.3V | 3.3 | A | F970J335MAA | 0.5 | 4 | 4.5 |
| | 4.7 | A | F970J475MAA | 0.5 | 6 | 4.0 |
| | 6.8 | A | F970J685MAA | 0.5 | 6 | 3.5 |
| | 6.8 | B | F970J685MBA | 0.5 | 6 | 2.5 |
| | 15 | B | F970J156MBA | 0.9 | 6 | 2.0 |
| | 22 | A | F970J226MAA | 1.4 | 12 | 2.5 |
| | 22 | B | F970J226MBA | 1.4 | 8 | 1.9 |
| | 33 | A | F970J336MAA | 2.1 | 12 | 2.5 |
| | 33 | C | F970J336MCC | 2.1 | 6 | 1.1 |
| | 47 | B | F970J476MBA | 3.0 | 8 | 1.0 |
| | 47 | C | F970J476MCC | 3.0 | 6 | 0.9 |
| | 68 | N | F970J686MNC | 4.3 | 6 | 0.6 |
| | 100 | N | F970J107MNC | 6.3 | 8 | 0.6 |
| 10V | 2.2 | A | F971A225MAA | 0.5 | 4 | 5.0 |
| | 3.3 | A | F971A335MAA | 0.5 | 4 | 4.5 |
| | 4.7 | A | F971A475MAA | 0.5 | 6 | 4.0 |
| | 4.7 | B | F971A475MBA | 0.5 | 6 | 2.8 |
| | 6.8 | B | F971A685MBA | 0.7 | 6 | 2.5 |
| | 10 | A | F971A106MAA | 1.0 | 6 | 3.0 |
| | 10 | B | F971A106MBA | 1.0 | 6 | 2.0 |
| | 15 | B | F971A156MBA | 1.5 | 6 | 2.0 |
| | 22 | A | F971A226MAA | 2.2 | 15 | 3.0 |
| | 22 | B | F971A226MBA | 2.2 | 8 | 1.9 |
| | 33 | B | F971A336MBA | 3.3 | 8 | 1.9 |
| | 33 | C | F971A336MCC | 3.3 | 6 | 1.1 |
| | 33 | N | F971A336MNC | 3.3 | 6 | 0.7 |
| | 47 | C | F971A476MCC | 4.7 | 8 | 0.9 |
| | 47 | N | F971A476MNC | 4.7 | 6 | 0.7 |
| 68 | N | F971A686MNC | 6.8 | 6 | 0.6 | |
| 16V | 1.5 | A | F971C155MAA | 0.5 | 4 | 6.3 |
| | 2.2 | A | F971C225MAA | 0.5 | 4 | 5.0 |
| | 3.3 | A | F971C335MAA | 0.5 | 4 | 4.5 |
| | 4.7 | A | F971C475MAA | 0.8 | 8 | 4.0 |
| | 4.7 | B | F971C475MBA | 0.8 | 6 | 2.8 |
| | 6.8 | B | F971C685MBA | 1.1 | 6 | 2.5 |
| | 10 | A | F971C106MAA | 1.6 | 8 | 3.5 |
| | 10 | B | F971C106MBA | 1.6 | 6 | 2.1 |
| | 10 | C | F971C106MCC | 1.6 | 6 | 1.5 |
| | 15 | C | F971C156MCC | 2.4 | 6 | 1.2 |
| | 22 | B | F971C226MBA | 3.5 | 8 | 1.9 |
| | 22 | C | F971C226MCC | 3.5 | 8 | 1.1 |
| | 22 | N | F971C226MNC | 3.5 | 6 | 0.7 |
| | 33 | B | F971C336MBA | 5.3 | 10 | 2.1 |
| | 33 | C | F971C336MCC | 5.3 | 8 | 1.1 |
| 33 | N | F971C336MNC | 5.3 | 6 | 0.7 | |
| 47 | N | F971C476MNC | 7.5 | 8 | 0.7 | |
| 20V | 0.68 | A | F971D684MAA | 0.5 | 4 | 7.6 |
| | 1 | A | F971D105MAA | 0.5 | 4 | 7.5 |
| | 1.5 | A | F971D155MAA | 0.5 | 4 | 6.7 |
| | 2.2 | A | F971D225MAA | 0.5 | 6 | 6.3 |
| | 3.3 | B | F971D335MBA | 0.7 | 4 | 3.1 |
| | 4.7 | A | F971D475MAA | 0.9 | 8 | 4.0 |
| | 4.7 | B | F971D475MBA | 0.9 | 6 | 2.8 |
| | 6.8 | C | F971D685MCC | 1.4 | 6 | 1.8 |
| | 10 | C | F971D106MCC | 2.0 | 6 | 1.5 |
| | 15 | N | F971D156MNC | 3.0 | 6 | 0.7 |
| | 22 | C | F971D226MCC | 4.4 | 8 | 1.1 |
| | 22 | N | F971D226MNC | 4.4 | 6 | 0.7 |

| Rated Volt | Rated Capacitance (μF) | Case code | Part Number | Leakage Current (μA) | Dissipation Factor (%@120Hz) | ESR (Ω@100kHz) |
|------------|------------------------|-----------|-------------|----------------------|------------------------------|----------------|
| 25V | 0.68 | A | F971E684MAA | 0.5 | 4 | 7.6 |
| | 1 | A | F971E105MAA | 0.5 | 4 | 7.5 |
| | 2.2 | B | F971E225MBA | 0.6 | 4 | 3.8 |
| | 3.3 | B | F971E335MBA | 0.8 | 4 | 3.5 |
| | 4.7 | C | F971E475MCC | 1.2 | 6 | 1.8 |
| | 6.8 | C | F971E685MCC | 1.7 | 6 | 1.8 |
| | 10 | C | F971E106MCC | 2.5 | 6 | 1.6 |
| | 10 | N | F971E106MNC | 2.5 | 6 | 1.0 |
| | 15 | N | F971E156MNC | 3.8 | 6 | 0.7 |
| | 35V | 0.47 | A | F971V474MAA | 0.5 | 4 |
| 0.68 | | A | F971V684MAA | 0.5 | 4 | 7.6 |
| 1.5 | | B | F971V155MBA | 0.5 | 4 | 4.0 |
| 2.2 | | B | F971V225MBA | 0.8 | 4 | 3.8 |
| 3.3 | | C | F971V335MCC | 1.2 | 4 | 2.0 |
| 4.7 | | C | F971V475MCC | 1.6 | 6 | 1.8 |
| 6.8 | | N | F971V685MNC | 2.4 | 6 | 1.0 |
| 10 | | N | F971V106MNC | 3.5 | 6 | 1.0 |

※ In case of capacitance tolerance ±10% type, **K** will be put at 9th digit of type numbering system.

TRM Professional Multianode



Tantalum Ultra Low ESR Capacitor

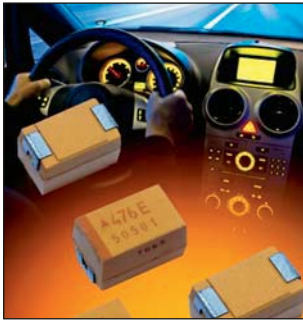

- Improved reliability – 0.5%/1khrs (twice better than standard)
- DCL reduced by 25% to 0.0075 CV
- Robust against higher thermo-mechanical stresses during assembly process
- Multi-anode construction
- Super low ESR
- CV range 22-1500 μ F / 2.5-35V
- “Mirror” construction used with D case capacitors reduces ESL to half
- Automotive, medical, aerospace, military and other hi-end application



SnPb termination option is not RoHS compliant.

MULTIANODE CONSTRUCTION

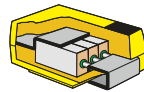

MULTIANODE TRMD LOW SELF INDUCTANCE CONSTRUCTION “MIRROR” DESIGN

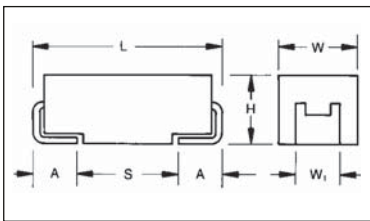
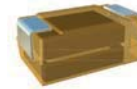

CASE DIMENSIONS: millimeters (inches)

| Code | EIA Code | EIA Metric | L \pm 0.20 (0.008) | W+0.20 (0.008) -0.10 (0.004) | H+0.20 (0.008) -0.10 (0.004) | W ₁ \pm 0.20 (0.008) | A+0.30 (0.012) -0.20 (0.008) | S Min. |
|------|----------|------------|----------------------|------------------------------|------------------------------|-----------------------------------|------------------------------|--------------|
| D | 2917 | 7343-31 | 7.30 (0.287) | 4.30 (0.169) | 2.90 (0.114) | 2.40 (0.094) | 1.30 (0.051) | 4.40 (0.173) |
| E | 2917 | 7343-43 | 7.30 (0.287) | 4.30 (0.169) | 4.10 (0.162) | 2.40 (0.094) | 1.30 (0.051) | 4.40 (0.173) |

W₁ dimension applies to the termination width for A dimensional area only.

For part marking see page 151

HOW TO ORDER

TRM

Type

E

Case Size
See table above

108

Capacitance Code
pF code: 1st two digits represent significant figures, 3rd digit represents multiplier (number of zeros to follow)

Tolerance
K= \pm 10%
M= \pm 20%

004

Rated DC Voltage
002 = 2.5Vdc
004 = 4Vdc
006 = 6.3Vdc
010 = 10Vdc
012 = 12Vdc
016 = 16Vdc
020 = 20Vdc
025 = 25Vdc
035 = 35Vdc

R

Packaging

R = Pure Tin 7" Reel
S = Pure Tin 13" Reel
H = Tin Lead 7" Reel (Contact Manufacturer)
K = Tin Lead 13" Reel (Contact Manufacturer)
H, K = Non RoHS

0023

ESR in m Ω

TECHNICAL SPECIFICATIONS

Technical Data:

All technical data relate to an ambient temperature of +25°C

Capacitance Range: 22 μ F to 1500 μ F

Capacitance Tolerance: \pm 10%; \pm 20%

| Rated Voltage (V _R) | \leq +85°C: | 2.5 | 4 | 6.3 | 10 | 12 | 16 | 20 | 25 | 35 |
|------------------------------------|----------------|-----|-----|-----|----|------|----|----|----|----|
| Category Voltage (V _C) | \leq +125°C: | 1.7 | 2.7 | 4 | 7 | 8.4 | 10 | 13 | 17 | 23 |
| Surge Voltage (V _S) | \leq +85°C: | 3.3 | 5.2 | 8 | 13 | 15.6 | 20 | 26 | 32 | 46 |
| Surge Voltage (V _S) | \leq +125°C: | 2.2 | 3.4 | 5 | 8 | 9.6 | 13 | 16 | 20 | 28 |

Temperature Range: -55°C to +125°C

Reliability: 0.5% per 1000 hours at 85°C, V_R with 0.1 Ω /V series impedance, 60% confidence level

Meets requirements of AEC-Q200



TRM Professional Multianode



Tantalum Ultra Low ESR Capacitor

CAPACITANCE AND RATED VOLTAGE, VR (VOLTAGE CODE) RANGE (LETTER DENOTES CASE SIZE)

| Capacitance | | Rated Voltage DC (V _R) to 85°C | | | | | | | | | |
|-------------|------|--|--------|----------|---------|---------|----------|----------|---------|-----------------|---------|
| μF | Code | 2.5V (e) | 4V (G) | 6.3V (J) | 10V (A) | 12V (B) | 16V (C) | 20V (D) | 25V (E) | 35V (V) | 50V (T) |
| 6.8 | 685 | | | | | | | | | | |
| 10 | 106 | | | | | | | | | | E(150)* |
| 15 | 156 | | | | | | | | | | |
| 22 | 226 | | | | | | | | | D(70)/E(60,100) | |
| 33 | 336 | | | | | | | | D(65) | E(50,65) | |
| 47 | 476 | | | | | | | D(55) | E(65) | | |
| 68 | 686 | | | | | | | | | | |
| 100 | 107 | | | | | | D(55)* | E(35,45) | | | |
| 150 | 157 | | | | D(45)* | | E(30,40) | | | | |
| 220 | 227 | | | | D(35) | E(35) | | | | | |
| 330 | 337 | | D(35) | D(35) | E(35) | | | | | | |
| 470 | 477 | | D(35) | E(30) | | | | | | | |
| 680 | 687 | | E(23) | | | | | | | | |
| 1000 | 108 | D(25) | E(23) | | | | | | | | |
| 1500 | 158 | E(18) | | | | | | | | | |
| 2200 | 228 | | | | | | | | | | |

Available Ratings, (ESR ratings in mOhms in brackets)

Engineering samples - please contact manufacturer

*Codes under development - subject to change

Note: Voltage ratings are minimum values. AVX reserves the right to supply higher ratings in the same case size, to the same reliability standards.

TRM Professional Multianode



Tantalum Ultra Low ESR Capacitor

RATINGS & PART NUMBER REFERENCE

| AVX Part No. | Case Size | Capacitance (µF) | Rated Voltage (V) | DCL (µA) Max. | DF % Max. | ESR Max. (mΩ) @100kHz | MSL | 100kHz RMS Current (A) | | | 100kHz RMS Voltage (V) | | |
|---|-----------|------------------|-------------------|---------------|-----------|-----------------------|-----|------------------------|-------|-------|------------------------|-------|-------|
| | | | | | | | | 25°C | 85°C | 125°C | 25°C | 85°C | 125°C |
| 2.5 Volt @ 85°C (1.7 Volt @ 125°C) | | | | | | | | | | | | | |
| TRMD108*002#0025 | D | 1000 | 2.5 | 18.8 | 8 | 25 | 3 | 3.194 | 2.874 | 1.277 | 0.080 | 0.072 | 0.032 |
| TRME158*002#0018 | E | 1500 | 2.5 | 28.1 | 6 | 18 | 3 | 3.873 | 3.486 | 1.549 | 0.070 | 0.063 | 0.028 |
| 4 Volt @ 85°C (2.7 Volt @ 125°C) | | | | | | | | | | | | | |
| TRMD337*004#0035 | D | 330 | 4 | 9.9 | 8 | 35 | 3 | 2.699 | 2.429 | 1.080 | 0.094 | 0.085 | 0.038 |
| TRMD477*004#0035 | D | 470 | 4 | 14.1 | 8 | 35 | 3 | 2.699 | 2.429 | 1.080 | 0.094 | 0.085 | 0.038 |
| TRME687*004#0023 | E | 680 | 4 | 20.4 | 6 | 23 | 3 | 3.426 | 3.084 | 1.370 | 0.079 | 0.071 | 0.032 |
| TRME108*004#0023 | E | 1000 | 4 | 30 | 6 | 23 | 3 | 3.426 | 3.084 | 1.370 | 0.079 | 0.071 | 0.032 |
| 6.3 Volt @ 85°C (4 Volt @ 125°C) | | | | | | | | | | | | | |
| TRMD337*006#0035 | D | 330 | 6.3 | 14.9 | 8 | 35 | 3 | 2.699 | 2.429 | 1.080 | 0.094 | 0.085 | 0.038 |
| TRME477*006#0030 | E | 470 | 6.3 | 21.2 | 6 | 30 | 3 | 3.000 | 2.700 | 1.200 | 0.090 | 0.081 | 0.036 |
| 10 Volt @ 85°C (7 Volt @ 125°C) | | | | | | | | | | | | | |
| TRMD227*010#0035 | D | 220 | 10 | 16.5 | 8 | 35 | 3 | 2.699 | 2.429 | 1.080 | 0.094 | 0.085 | 0.038 |
| TRME337*010#0035 | E | 330 | 10 | 24.8 | 6 | 35 | 3 | 2.777 | 2.500 | 1.111 | 0.097 | 0.087 | 0.039 |
| 12 Volt @ 85°C (8.4 Volt @ 125°C) | | | | | | | | | | | | | |
| TRME227*012#0035 | E | 220 | 12 | 19.8 | 6 | 35 | 3 | 2.777 | 2.500 | 1.111 | 0.097 | 0.087 | 0.039 |
| 16 Volt @ 85°C (10 Volt @ 125°C) | | | | | | | | | | | | | |
| TRME157*016#0030 | E | 150 | 16 | 18 | 6 | 30 | 3 | 3.000 | 2.700 | 1.200 | 0.090 | 0.081 | 0.036 |
| TRME157*016#0040 | E | 150 | 16 | 18 | 6 | 40 | 3 | 2.598 | 2.338 | 1.039 | 0.104 | 0.094 | 0.042 |
| 20 Volt @ 85°C (13 Volt @ 125°C) | | | | | | | | | | | | | |
| TRMD476*020#0055 | D | 47 | 20 | 7.1 | 8 | 55 | 3 | 2.153 | 1.938 | 0.861 | 0.118 | 0.107 | 0.047 |
| TRME107*020#0035 | E | 100 | 20 | 15 | 6 | 35 | 3 | 2.777 | 2.500 | 1.111 | 0.097 | 0.087 | 0.039 |
| TRME107*020#0045 | E | 100 | 20 | 15 | 6 | 45 | 3 | 2.449 | 2.205 | 0.980 | 0.110 | 0.099 | 0.044 |
| 25 Volt @ 85°C (17 Volt @ 125°C) | | | | | | | | | | | | | |
| TRMD336*025#0065 | D | 33 | 25 | 6.2 | 8 | 65 | 3 | 1.981 | 1.783 | 0.792 | 0.129 | 0.116 | 0.051 |
| TRME476*025#0065 | E | 47 | 25 | 8.8 | 6 | 65 | 3 | 2.038 | 1.834 | 0.815 | 0.132 | 0.119 | 0.053 |
| 35 Volt @ 85°C (23 Volt @ 125°C) | | | | | | | | | | | | | |
| TRMD226*035#0070 | D | 22 | 35 | 5.8 | 8 | 70 | 3 | 1.909 | 1.718 | 0.763 | 0.134 | 0.120 | 0.053 |
| TRME226*035#0060 | E | 22 | 35 | 5.8 | 6 | 60 | 3 | 2.121 | 1.909 | 0.849 | 0.127 | 0.115 | 0.051 |
| TRME226*035#0100 | E | 22 | 35 | 5.8 | 6 | 100 | 3 | 1.643 | 1.479 | 0.657 | 0.164 | 0.148 | 0.066 |
| TRME336*035#0050 | E | 33 | 35 | 8.7 | 6 | 50 | 3 | 2.324 | 2.091 | 0.930 | 0.116 | 0.105 | 0.046 |
| TRME336*035#0065 | E | 33 | 35 | 8.7 | 6 | 65 | 3 | 2.038 | 1.834 | 0.815 | 0.132 | 0.119 | 0.053 |

Moisture Sensitivity Level (MSL) is defined according to J-STD-020.

All technical data relates to an ambient temperature of +25°C. Capacitance and DF are measured at 120Hz, 0.5V RMS with a maximum DC bias of 2.2 volts. DCL is measured at rated voltage after 5 minutes.

The EIA & CECC standards for low ESR Solid Tantalum Capacitors allow an ESR movement to 1.25 times catalogue limit post mounting.

For typical weight and composition see page 144.

NOTE: AVX reserves the right to supply a higher voltage rating or tighter tolerance part in the same case size, to the same reliability standards.

THJ Series



High Temperature Tantalum Chip Capacitor



- Improved reliability – 2x standard
- 175°C @ 0.5V_R continuous operation
- CV range: 0.10-220µF / 6.3-50V
- 5 case sizes available
- Low ESR options on approval
- High temperature automotive and industry applications



SnPb termination option is not RoHS compliant.

CASE DIMENSIONS: millimeters (inches)

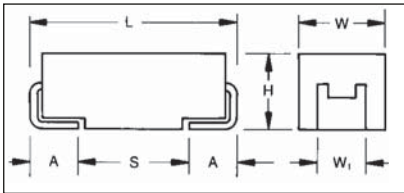

For part marking see page 151

| Code | EIA Code | EIA Metric | L±0.20 (0.008) | W+0.20 (0.008) -0.10 (0.004) | H+0.20 (0.008) -0.10 (0.004) | W ₁ ±0.20 (0.008) | A+0.30 (0.012) -0.20 (0.008) | S Min. |
|------|----------|------------|----------------|------------------------------|------------------------------|------------------------------|------------------------------|--------------|
| A | 1206 | 3216-18 | 3.20 (0.126) | 1.60 (0.063) | 1.60 (0.063) | 1.20 (0.047) | 0.80 (0.031) | 1.10 (0.043) |
| B | 1210 | 3528-21 | 3.50 (0.138) | 2.80 (0.110) | 1.90 (0.075) | 2.20 (0.087) | 0.80 (0.031) | 1.40 (0.055) |
| C | 2312 | 6032-28 | 6.00 (0.236) | 3.20 (0.126) | 2.60 (0.102) | 2.20 (0.087) | 1.30 (0.051) | 2.90 (0.114) |
| D | 2917 | 7343-31 | 7.30 (0.287) | 4.30 (0.169) | 2.90 (0.114) | 2.40 (0.094) | 1.30 (0.051) | 4.40 (0.173) |
| E | 2917 | 7343-43 | 7.30 (0.287) | 4.30 (0.169) | 4.10 (0.162) | 2.40 (0.094) | 1.30 (0.051) | 4.40 (0.173) |

W₁ dimension applies to the termination width for A dimensional area only.

HOW TO ORDER

| | | | | | | | |
|-------------|-------------------------------------|---|--------------------------------------|---|--|---|---|
| THJ | B | 105 | * | 035 | R | JN | - |
| Type | Case Size See table above | Capacitance Code pF code: 1st two digits represent significant figures 3rd digit represents multiplier (number of zeros to follow) | Tolerance K=±10% M=±20% | Rated DC Voltage 006=6.3Vdc 010=10Vdc 016=16Vdc 020=20Vdc 025=25Vdc 035=35Vdc 050=50Vdc | Packaging R = Pure Tin 7" Reel S = Pure Tin 13" Reel A = Gold Plating 7" Reel B = Gold Plating 13" Reel H = Tin Lead 7" Reel (Contact Manufacturer) K = Tin Lead 13" Reel (Contact Manufacturer) H, K = Non RoHS | Standard Suffix OR 0100 Low ESR in mΩ | Additional characters may be added for special requirements V = Dry pack Option (selected codes only) |

TECHNICAL SPECIFICATIONS

| | | | | | | | | | |
|------------------------------------|---|-----|----|----|----|----|----|----|--|
| Technical Data: | All technical data relate to an ambient temperature of +25°C | | | | | | | | |
| Capacitance Range: | 0.10 µF to 220 µF | | | | | | | | |
| Capacitance Tolerance: | ±10%; ±20% | | | | | | | | |
| Rated Voltage (V _R) | ≤ +85°C: | 6.3 | 10 | 16 | 20 | 25 | 35 | 50 | |
| Category Voltage (V _C) | ≤ +125°C: | 4 | 7 | 10 | 13 | 17 | 23 | 33 | |
| Category Voltage (V _C) | ≤ +175°C: | 3 | 5 | 8 | 10 | 12 | 17 | 25 | |
| Surge Voltage (V _S) | ≤ +85°C: | 8 | 13 | 20 | 26 | 32 | 46 | 65 | |
| Surge Voltage (V _S) | ≤ +125°C: | 5 | 8 | 13 | 16 | 20 | 28 | 40 | |
| Surge Voltage (V _S) | ≤ +175°C: | 4 | 6 | 10 | 12 | 15 | 21 | 30 | |
| Temperature Range: | -55°C to 175°C voltage derating. | | | | | | | | |
| Reliability: | 0.5% per 1000 hours at 85°C, V _R with 0.1Ω/V series impedance, 60% confidence level, 3.5 Fits at 40°C, 0.5V _R | | | | | | | | |
| Termination Finish: | Sn Plating (standard), Gold Plating available on request | | | | | | | | |
| | Meets requirements of AEC-Q200 | | | | | | | | |



THJ Series



High Temperature Tantalum Chip Capacitor

CAPACITANCE AND RATED VOLTAGE, VR (VOLTAGE CODE) RANGE (LETTER DENOTES CASE SIZE)

| Capacitance | | Rated voltage (V _R) to 85°C (Voltage Code) | | | | | | |
|----------------------|-------------------|--|-------------|---------------------|---------|---------|---------------------|-------------|
| µF | Code | 6.3V (J) | 10V (A) | 16V (C) | 20V (D) | 25V (E) | 35V (V) | 50V (T) |
| 0.10 0.15 0.22 | 104 154 224 | | | | | | A A A | |
| 0.33 0.47 0.68 | 334 474 684 | | | | | A A | A B B | |
| 1.0 1.5 2.2 | 105 155 225 | | | A | A | A B | A/B C C | |
| 3.3 4.7 6.8 | 335 475 685 | A A | A A A | A A/B A/B | B | C | C C D | D D D |
| 10 15 22 | 106 156 226 | A B B | B B B | B B C, C(500) | C | C D | D D D, D(300) | D/E |
| 33 47 68 | 336 476 686 | B C C | C C D | C C/D D | D | D | E | |
| 100 150 220 | 107 157 227 | D D | D E | E | | | | |

Available Ratings, (ESR ratings in mOhms in brackets)

Engineering samples - please contact manufacturer

*Codes under development - subject to change

Note: Voltage ratings are minimum values. AVX reserves the right to supply higher ratings in the same case size, to the same reliability standards.

THJ Series



High Temperature Tantalum Chip Capacitor

RATINGS & PART NUMBER REFERENCE

| AVX Part No. | Case Size | Cap (µF) | Rated Voltage (V) | DCL (µA) Max. | DF % Max. | ESR Max. (Ω) @100kHz | MSL |
|---|-----------|----------|-------------------|---------------|-----------|----------------------|-----------------|
| 6.3 Volt @ 85°C (3 Volt @ 175°C) / J | | | | | | | |
| THJA475*006#JN | A | 4.7 | 6.3 | 0.5 | 6 | 6 | 1 |
| THJA685*006#JN | A | 6.8 | 6.3 | 0.5 | 4.5 | 2.6 | 1 |
| THJA106*006#JN | A | 10 | 6.3 | 0.6 | 4.5 | 2.2 | 1 |
| THJB156*006#JN | B | 15 | 6.3 | 0.9 | 6 | 2.5 | 1 |
| THJB226*006#JN | B | 22 | 6.3 | 1.4 | 6 | 2.5 | 1 |
| THJB336*006#JN | B | 33 | 6.3 | 1.9 | 6 | 2.2 | 1 |
| THJC476*006#JN | C | 47 | 6.3 | 3.0 | 6 | 1.6 | 1 |
| THJC686*006#JN | C | 68 | 6.3 | 4.3 | 6 | 1.5 | 1 |
| THJD107*006#JN | D | 100 | 6.3 | 6 | 4.5 | 0.4 | 1 |
| THJD157*006#JN | D | 150 | 6.3 | 9.5 | 6 | 0.9 | 1 |
| 10 Volt @ 85°C (5 Volt @ 175°C) / A | | | | | | | |
| THJA335*010#JN | A | 3.3 | 10 | 0.5 | 6 | 5.5 | 1 |
| THJA475*010#JN | A | 4.7 | 10 | 0.5 | 4.5 | 2.9 | 1 |
| THJA685*010#JN | A | 6.8 | 10 | 0.7 | 4.5 | 2.6 | 1 |
| THJB106*010#JN | B | 10 | 10 | 1 | 4.5 | 1.8 | 1 |
| THJB156*010#JN | B | 15 | 10 | 1.5 | 4.5 | 1.5 | 1 |
| THJB226*010#JN | B | 22 | 10 | 2.2 | 6 | 2.4 | 1 |
| THJC336*010#JN | C | 33 | 10 | 3.3 | 6 | 1.6 | 1 |
| THJC476*010#JN | C | 47 | 10 | 4.7 | 4.5 | 0.5 | 1 |
| THJD686*010#JN | D | 68 | 10 | 6.8 | 4.5 | 0.4 | 1 |
| THJD107*010#JN | D | 100 | 10 | 10 | 6 | 0.9 | 1 |
| THJE227*010#JN | E | 220 | 10 | 22 | 10 | 0.5 | 1 ¹⁾ |
| 16 Volt @ 85°C (8 Volt @ 175°C) / C | | | | | | | |
| THJA225*016#JN | A | 2.2 | 16 | 0.5 | 6 | 6.5 | 1 |
| THJA335*016#JN | A | 3.3 | 16 | 0.5 | 6 | 5 | 1 |
| THJA475*016#JN | A | 4.7 | 16 | 0.8 | 4.5 | 2.9 | 1 |
| THJB475*016#JN | B | 4.7 | 16 | 0.8 | 6 | 3.5 | 1 |
| THJA685*016#JN | A | 6.8 | 16 | 1.1 | 6 | 3.5 | 1 |
| THJB685*016#JN | B | 6.8 | 16 | 1.1 | 6 | 2.5 | 1 |
| THJB106*016#JN | B | 10 | 16 | 1.6 | 6 | 2.8 | 1 |
| THJB156*016#JN | B | 15 | 16 | 2.4 | 6 | 2 | 1 |
| THJC226*016#JN | C | 22 | 16 | 3.5 | 6 | 1.6 | 1 |
| THJC226*016#0500 | C | 22 | 16 | 3.5 | 4.5 | 0.5 | 1 |
| THJC336*016#JN | C | 33 | 16 | 5.3 | 6 | 1.5 | 1 |
| THJC476*016#JN | C | 47 | 16 | 7.5 | 6 | 0.8 | 1 |
| THJD476*016#JN | D | 47 | 16 | 7.5 | 6 | 0.9 | 1 |
| THJD686*016#JN | D | 68 | 16 | 10.9 | 4.5 | 0.9 | 1 |
| THJE107*016#JN | E | 100 | 16 | 16 | 8 | 0.4 | 1 ¹⁾ |

| AVX Part No. | Case Size | Cap (µF) | Rated Voltage (V) | DCL (µA) Max. | DF % Max. | ESR Max. (Ω) @100kHz | MSL |
|---|-----------|----------|-------------------|---------------|-----------|----------------------|-----------------|
| 20 Volt @ 85°C (10 Volt @ 175°C) / D | | | | | | | |
| THJA155*020#JN | A | 1.5 | 20 | 0.5 | 6 | 6.5 | 1 |
| THJB335*020#JN | B | 3.3 | 20 | 0.7 | 6 | 3 | 1 |
| THJC156*020#JN | C | 15 | 20 | 3.0 | 6 | 1.7 | 1 |
| THJD336*020#JN | D | 33 | 20 | 6.6 | 6 | 0.9 | 1 |
| 25 Volt @ 85°C (12 Volt @ 175°C) / E | | | | | | | |
| THJA474*025#JN | A | 0.47 | 25 | 0.5 | 4 | 14 | 1 |
| THJA684*025#JN | A | 0.68 | 25 | 0.5 | 4 | 10 | 1 |
| THJA105*025#JN | A | 1.0 | 25 | 0.5 | 3 | 5.2 | 1 |
| THJB225*025#JN | B | 2.2 | 25 | 0.6 | 6 | 4.5 | 1 |
| THJC685*025#JN | C | 6.8 | 25 | 1.7 | 6 | 2 | 1 |
| THJC106*025#JN | C | 10 | 25 | 2.5 | 6 | 1.8 | 1 |
| THJD226*025#JN | D | 22 | 25 | 5.5 | 6 | 0.9 | 1 |
| THJD336*025#JN | D | 33 | 25 | 8.3 | 6 | 0.9 | 1 |
| 35 Volt @ 85°C (17 Volt @ 175°C) / V | | | | | | | |
| THJA104*035#JN | A | 0.1 | 35 | 0.5 | 4 | 24 | 1 |
| THJA154*035#JN | A | 0.15 | 35 | 0.5 | 4 | 21 | 1 |
| THJA224*035#JN | A | 0.22 | 35 | 0.5 | 4 | 18 | 1 |
| THJA334*035#JN | A | 0.33 | 35 | 0.5 | 4 | 15 | 1 |
| THJB474*035#JN | B | 0.47 | 35 | 0.5 | 4 | 10 | 1 |
| THJB684*035#JN | B | 0.68 | 35 | 0.5 | 4 | 8 | 1 |
| THJA105*035#JN | A | 1.0 | 35 | 0.5 | 4 | 7.5 | 1 |
| THJB105*035#JN | B | 1.0 | 35 | 0.5 | 4 | 6.5 | 1 |
| THJC155*035#JN | C | 1.5 | 35 | 0.5 | 6 | 4.5 | 1 |
| THJC225*035#JN | C | 2.2 | 35 | 0.8 | 6 | 3.5 | 1 |
| THJC335*035#JN | C | 3.3 | 35 | 1.2 | 6 | 2.5 | 1 |
| THJC475*035#JN | C | 4.7 | 35 | 1.6 | 6 | 2.2 | 1 |
| THJD685*035#JN | D | 6.8 | 35 | 2.4 | 6 | 1.3 | 1 |
| THJD106*035#JN | D | 10 | 35 | 3.5 | 6 | 1 | 1 |
| THJD156*035#JN | D | 15 | 35 | 5.3 | 6 | 0.9 | 1 |
| THJD226*035#JN | D | 22 | 35 | 7.7 | 6 | 0.6 | 1 |
| THJD226*035#0300 | D | 22 | 35 | 7.7 | 6 | 0.3 | 1 |
| THJE336*035#JN | E | 33 | 35 | 11.6 | 6 | 0.5 | 1 ¹⁾ |
| 50 Volt @ 85°C (25 Volt @ 175°C) / T | | | | | | | |
| THJD335*050#JN | D | 3.3 | 50 | 1.7 | 6 | 1.1 | 1 |
| THJD475*050#JN | D | 4.7 | 50 | 2.4 | 6 | 0.9 | 1 |
| THJD685*050#JN | D | 6.8 | 50 | 3.4 | 6 | 0.7 | 1 |
| THJD106*050#JN | D | 10 | 50 | 5 | 6 | 0.7 | 1 |
| THJE106*050#JN | E | 10 | 50 | 5 | 6 | 0.7 | 1 ¹⁾ |

1¹⁾ Dry pack option (see How to order) recommended for reduction of stress during soldering. Dry pack parts should be treated as MSL 3.

Moisture Sensitivity Level (MSL) is defined according to J-STD-020.

All technical data relates to an ambient temperature of +25°C. Capacitance and DF are measured at 120Hz, 0.5V RMS with a maximum DC bias of 2.2 volts. DCL is measured at rated voltage after 5 minutes.

The EIA & CECC standards for low ESR Solid Tantalum Capacitors allow an ESR movement to 1.25 times catalogue limit post mounting.

For typical weight and composition see page 144.

NOTE: AVX reserves the right to supply a higher voltage rating or tighter tolerance part in the same case size, to the same reliability standards.

THJ 175°C Voltage vs Temperature Rating

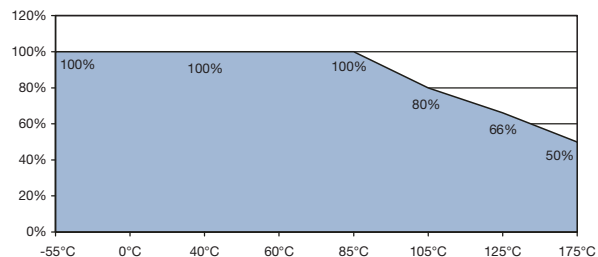

THJ Series with Extension to 200°C



High Temperature Tantalum Chip Capacitor



- SMD 200°C tantalum capacitor
- 200°C @ 0.33V_R 1000hrs continuous operation
- Leakage current after 200°C 1000hrs less than 1mA
- 3x reflow 260°C
- Gold plated termination for hybrid assembly
- Oil drilling, aerospace, automotive applications
- CV range: 10-220μF / 10-16V
- 2 case sizes available

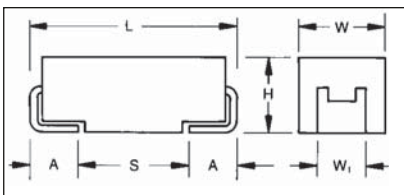

For part marking see page 151

CASE DIMENSIONS: millimeters (inches)

| Code | EIA Code | EIA Metric | L±0.20 (0.008) | W±0.20 (0.008) -0.10 (0.004) | H±0.20 (0.008) -0.10 (0.004) | W ₁ ±0.20 (0.008) | A±0.30 (0.012) -0.20 (0.008) | S Min. |
|------|----------|------------|----------------|---------------------------------|---------------------------------|------------------------------|---------------------------------|--------------|
| B | 1210 | 3528-21 | 3.50 (0.138) | 2.80 (0.110) | 1.90 (0.075) | 2.20 (0.087) | 0.80 (0.031) | 1.40 (0.055) |
| E | 2917 | 7343-43 | 7.30 (0.287) | 4.30 (0.169) | 4.10 (0.162) | 2.40 (0.094) | 1.30 (0.051) | 4.40 (0.173) |

W₁ dimension applies to the termination width for A dimensional area only.

HOW TO ORDER

| | | | | | | |
|-------------|-------------------------------------|---|--------------------------------------|---|---|------------------------|
| THJ | E | 107 | * | 016 | A | JH |
| Type | Case Size See table above | Capacitance Code pF code: 1st two digits represent significant figures 3rd digit represents multiplier (number of zeros to follow) | Tolerance K=±10% M=±20% | Rated DC Voltage 010=10Vdc 016=16Vdc | Packaging A = Gold Plating 7" Reel B = Gold Plating 13" Reel | Standard Suffix |

TECHNICAL SPECIFICATIONS

| | | | |
|--|--|-----|-----|
| Technical Data: | All technical data relate to an ambient temperature of +25°C | | |
| Capacitance Range: | 10 μF to 220 μF | | |
| Capacitance Tolerance: | ±10%; ±20% | | |
| Leakage Current DCL @ V _R 25°C | 0.01CV | | |
| Leakage Current DCL @ V _C 200°C, 1000 hrs | 1mA | | |
| Rated Voltage (V _R) | ≤ +85°C: | 10 | 16 |
| Category Voltage (V _C) | ≤ +200°C: | 3.3 | 5.3 |
| Surge Voltage (V _S) | ≤ +85°C: | 13 | 20 |
| Surge Voltage (V _S) | ≤ +200°C: | 4.3 | 6.5 |
| Temperature Range: | -55°C up 200°C with voltage derating | | |
| Reliability: | 0.5% per 1000 hours at 85°C, V _R with 0.1Ω/V series impedance, 1000 hrs at 200°C, 0.33V _R | | |
| Termination Finished: | Gold Plating Meets requirements of AEC-Q200 | | |



THJ Series with Extension to 200°C



High Temperature Tantalum Chip Capacitor

CAPACITANCE AND RATED VOLTAGE, VR (VOLTAGE CODE) RANGE (LETTER DENOTES CASE SIZE)

| Capacitance | | Rated voltage (V _R) to 85°C (Voltage Code) | | | | | | |
|-------------|------|--|---------|---------|---------|---------|---------|---------|
| μF | Code | 6.3V (J) | 10V (A) | 16V (C) | 20V (D) | 25V (E) | 35V (V) | 50V (T) |
| 10 | 106 | | | B | | | | |
| 15 | 156 | | | | | | | |
| 22 | 226 | | | | | | | |
| 33 | 336 | | | | | | | |
| 47 | 476 | | | | | | | |
| 68 | 686 | | | | | | | |
| 100 | 107 | | | E | | | | |
| 150 | 157 | | E | | | | | |
| 220 | 227 | | | | | | | |
| 330 | 337 | | | | | | | |
| 470 | 477 | | | | | | | |
| 680 | 687 | | | | | | | |

Available Ratings

Engineering samples - please contact manufacturer

*Codes under development – subject to change

Note: Voltage ratings are minimum values. AVX reserves the right to supply higher ratings in the same case size, to the same reliability standards

RATINGS & PART NUMBER REFERENCE

| AVX Part No. | Case Size | Cap (μF) | Rated Voltage (V) | DCL (μA) Max. @ V _R 25°C | DCL (mA) Max. @ V _C 200°C 1000hrs | DF % Max. | ESR Max. (Ω) @ 100kHz | MSL | 100kHz RMS Current (mA) | | | | 100kHz RMS Voltage (mV) | | | |
|--|-----------|----------|-------------------|-------------------------------------|--|-----------|-----------------------|-----|-------------------------|------|-------|-------|-------------------------|------|-------|-------|
| | | | | | | | | | 25°C | 85°C | 175°C | 200°C | 25°C | 85°C | 175°C | 200°C |
| 10 Volt @ 85°C (3.3 Volt @ 200°C) | | | | | | | | | | | | | | | | |
| THJE227*010#JH | E | 220 | 10 | 22 | 1.0 | 10 | 0.25 | 1 | 812 | 731 | 162 | 81 | 203 | 183 | 41 | 20 |
| 16 Volt @ 85°C (5.3 Volt @ 200°C) | | | | | | | | | | | | | | | | |
| THJB106*016#JH | B | 10 | 16 | 1.6 | 1.0 | 6 | 2.8 | 1 | 174 | 157 | 35 | 17 | 488 | 439 | 98 | 49 |
| THJE107*016#JH | E | 100 | 16 | 16 | 1.0 | 8 | 0.25 | 1 | 812 | 731 | 162 | 81 | 203 | 183 | 41 | 20 |

Moisture Sensitivity Level (MSL) is defined according to J-STD-020.

All technical data relates to an ambient temperature of +25°C. Capacitance and DF are measured at 120Hz, 0.5V RMS with a maximum DC bias of 2.2 volts. DCL is measured at rated voltage after 5 minutes.

For typical weight and composition see page 144.

NOTE: AVX reserves the right to supply a higher voltage rating or tighter tolerance part in the same case size, to the same reliability standards.

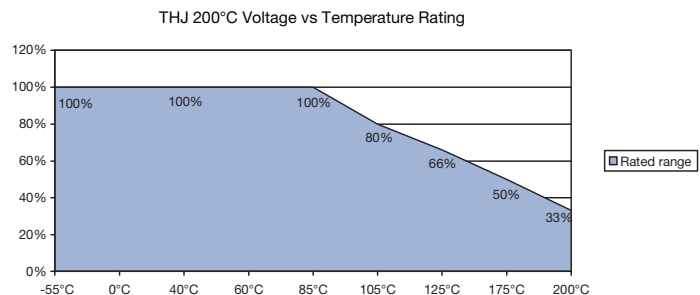

TAW Series



Tantalum Solid Electrolytic Fused Capacitors

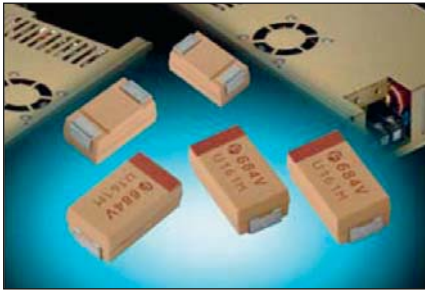

- Thin film fuse connected in series with capacitor
- Protection from possible damaging from high DC leakage current (short circuit failure)
- CV range: 6.8-100 μ F / 10-50V
- Application: servers



LEAD-FREE

LEAD-FREE COMPATIBLE COMPONENT



RoHS COMPLIANT

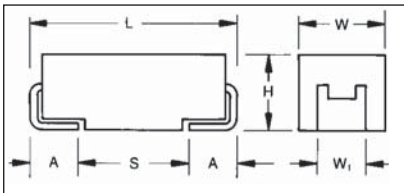

For part marking see page 151

CASE DIMENSIONS: millimeters (inches)

| Code | EIA Code | EIA Metric | L \pm 0.20 (0.008) | W \pm 0.20 (0.008) -0.10 (0.004) | H \pm 0.20 (0.008) -0.10 (0.004) | W ₁ \pm 0.20 (0.008) | A \pm 0.30 (0.012) -0.20 (0.008) | S Min. |
|------|----------|------------|----------------------|------------------------------------|------------------------------------|-----------------------------------|------------------------------------|--------------|
| D | 2917 | 7343-31 | 7.30 (0.287) | 4.30 (0.169) | 2.90 (0.114) | 2.40 (0.094) | 1.30 (0.051) | 4.40 (0.173) |

W₁ dimension applies to the termination width for A dimensional area only.

HOW TO ORDER

| | | | | | | |
|-------------|-------------------------------------|---|--|---|---|------------------------------------|
| TAW | D | 476 | * | 010 | R | 0500 |
| Type | Case Size See table above | Capacitance Code pF code: 1st two digits represent significant figures 3rd digit represents multiplier (number of zeros to follow) | Tolerance K= \pm 10% M= \pm 20% | Rated DC Voltage 010=10Vdc 016=16Vdc 020=20Vdc 025=25Vdc 035=35Vdc 050=50Vdc | Packaging R = Pure Tin 7" Reel S = Pure Tin 13" Reel | ESR in mΩ |

TECHNICAL SPECIFICATIONS

| | | | | | | | | |
|------------------------------------|---|----|----|----|----|----|----|--|
| Technical Data: | All technical data relate to an ambient temperature of +25°C | | | | | | | |
| Capacitance Range: | 6.8 μ F to 100 μ F | | | | | | | |
| Capacitance Tolerance: | \pm 10%; \pm 20% | | | | | | | |
| Rated Voltage (V _R) | \leq +85°C: | 10 | 16 | 20 | 25 | 35 | 50 | |
| Category Voltage (V _C) | \leq +125°C: | 7 | 10 | 13 | 17 | 23 | 33 | |
| Surge Voltage (V _S) | \leq +85°C: | 13 | 20 | 26 | 32 | 46 | 65 | |
| Surge Voltage (V _S) | \leq +125°C: | 8 | 13 | 16 | 20 | 28 | 40 | |
| Fuse Off | I > 4A in 1s, insulating resistance > 10M Ω | | | | | | | |
| Fuse Continuous Current Capability | 0.75A | | | | | | | |
| Temperature Range: | -55°C to +125°C | | | | | | | |
| Reliability: | 1% per 1000 hours at 85°C, V _r with 0.1 Ω /V series impedance, 60% confidence level | | | | | | | |



Tantalum Solid Electrolytic Fused Capacitors

CAPACITANCE AND RATED VOLTAGE, VR (VOLTAGE CODE) RANGE (LETTER DENOTES CASE SIZE)

| Capacitance | | Rated Voltage DC (V _R) to 85°C | | | | | | |
|-------------|------|--|---------|---------|---------|---------|---------|---------|
| μF | Code | 6.3V (J) | 10V (A) | 16V (C) | 20V (D) | 25V (E) | 35V (V) | 50V (T) |
| 1.0 | 105 | | | | | | | |
| 2.2 | 225 | | | | | | | |
| 4.7 | 475 | | | | | | | |
| 6.8 | 685 | | | | | | D(600) | D(700) |
| 10 | 106 | | | | | D(600) | D(600) | D(700) |
| 22 | 226 | | | | D(500) | D(600) | | |
| 33 | 336 | | | D(600) | D(500) | | | |
| 47 | 476 | | D(500) | D(800) | | | | |
| 100 | 107 | | D(500) | | | | | |

Available Ratings (ESR ratings in mOhms in brackets)

Engineering samples - please contact manufacturer

*Codes under development – subject to change

Note: Voltage ratings are minimum values. AVX reserves the right to supply higher ratings in the same case size, to the same reliability standards.

RATINGS & PART NUMBER REFERENCE

| AVX Part No. | Case Size | Capacitance (μF) | Rated Voltage (V) | DCL (μA) Max. | DF % Max. | ESR Max. (mΩ) @100kHz | MSL | 100kHz RMS Current (mA) | | | 100kHz RMS Voltage (mV) | | |
|---|-----------|------------------|-------------------|---------------|-----------|-----------------------|-----|-------------------------|------|-------|-------------------------|------|-------|
| | | | | | | | | 25°C | 85°C | 125°C | 25°C | 85°C | 125°C |
| 10 Volt @ 85°C (7 Volt @ 125°C) | | | | | | | | | | | | | |
| TAWD476*010#0500 | D | 47 | 10 | 4.7 | 6 | 500 | 1 | 548 | 493 | 219 | 274 | 246 | 110 |
| TAWD107*010#0500 | D | 100 | 10 | 10 | 8 | 500 | 1 | 548 | 493 | 219 | 274 | 246 | 110 |
| 16 Volt @ 85°C (10 Volt @ 125°C) | | | | | | | | | | | | | |
| TAWD336*016#0600 | D | 33 | 16 | 5.3 | 6 | 600 | 1 | 500 | 450 | 200 | 300 | 270 | 120 |
| TAWD476*016#0800 | D | 47 | 16 | 7.5 | 7 | 800 | 1 | 433 | 390 | 173 | 346 | 312 | 139 |
| 20 Volt @ 85°C (13 Volt @ 125°C) | | | | | | | | | | | | | |
| TAWD226*020#0500 | D | 22 | 20 | 4.4 | 6 | 500 | 1 | 548 | 493 | 219 | 274 | 246 | 110 |
| TAWD336*020#0500 | D | 33 | 20 | 6.6 | 6 | 500 | 1 | 548 | 493 | 219 | 274 | 246 | 110 |
| 25 Volt @ 85°C (17 Volt @ 125°C) | | | | | | | | | | | | | |
| TAWD106*025#0600 | D | 10 | 25 | 2.5 | 6 | 600 | 1 | 500 | 450 | 200 | 300 | 270 | 120 |
| TAWD226*025#0600 | D | 22 | 25 | 5.5 | 6 | 600 | 1 | 500 | 450 | 200 | 300 | 270 | 120 |
| 35 Volt @ 85°C (23 Volt @ 125°C) | | | | | | | | | | | | | |
| TAWD685*035#0600 | D | 6.8 | 35 | 2.4 | 6 | 600 | 1 | 500 | 450 | 200 | 300 | 270 | 120 |
| TAWD106*035#0600 | D | 10 | 35 | 3.5 | 6 | 600 | 1 | 500 | 450 | 200 | 300 | 270 | 120 |
| 50 Volt @ 85°C (33 Volt @ 125°C) | | | | | | | | | | | | | |
| TAWD685*050#0700 | D | 6.8 | 50 | 3.4 | 6 | 700 | 1 | 463 | 417 | 185 | 324 | 292 | 130 |
| TAWD106*050#0700 | D | 10 | 50 | 5 | 6 | 700 | 1 | 463 | 417 | 185 | 324 | 292 | 130 |

Moisture Sensitivity Level (MSL) is defined according to J-STD-020.

All technical data relates to an ambient temperature of +25°C. Capacitance and DF are measured at 120Hz, 0.5V RMS with a maximum DC bias of 2.2 volts. DCL is measured at rated voltage after 5 minutes.

For typical weight and composition see page 144.

NOTE: AVX reserves the right to supply a higher voltage rating or tighter tolerance part in the same case size, to the same reliability standards.

TYPICAL FUSE ACTUATION

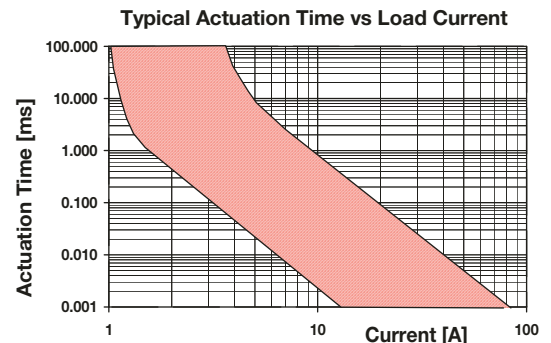

Note: for a different fuse characteristic requirements please contact manufacturer

AUDIO F95 Series



Conformal Coated Chip Optimized for Audio Applications

FRAMELESS™



- Compliant to the RoHS directive (2002/95/EC).

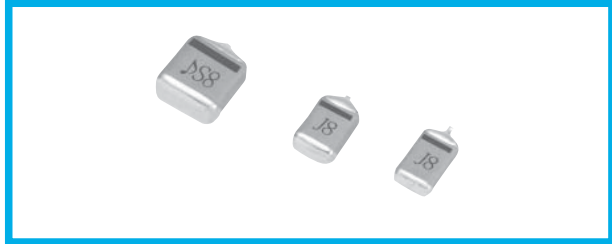

Applications

- Mobile Audio Player
- Smartphone
- Mobile phone
- Wireless Microphone System

Feature

- Rich sound in the bass register and clear sound, Materials are strictly selected to achieve high level sound. F95 series has no lead-frame, and no vibration factor.
- Low ESR, Low ESL
- Line up miniature size and high capacitance, necessary to mobile design.

Type numbering system (Example : 4V 220μF)

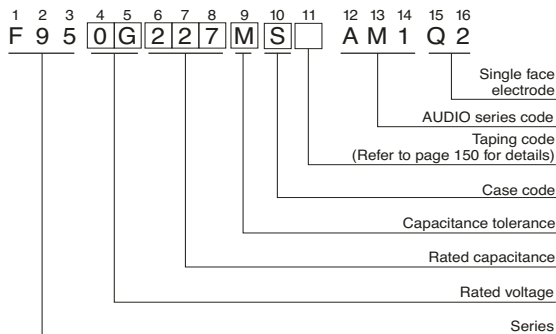

Drawing

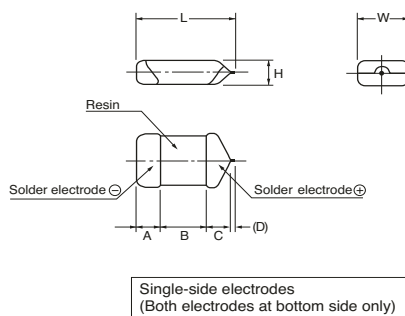

Specifications

| Item | Performance Characteristics |
|-----------------------------------|---|
| Category | –55 to +125°C (Rated temperature : +85°C) |
| Temperature Range | |
| Capacitance Tolerance | ±20%, ±10% (at 120Hz) |
| Dissipation Factor (at 120Hz) | Refer to next page |
| ESR(100kHz) | Refer to next page |
| Leakage Current | Refer to next page Provided that • After 1 minute's application of rated voltage, leakage current at 85°C, 10 times or less than 20°C specified value. • After 1 minute's application of rated voltage, leakage current at 125°C, 12.5 times or less than 20°C specified value. |
| Capacitance Change by Temperature | +15% Max. (at +125°C) +10% Max. (at +85°C) –10% Max. (at –55°C) |
| Damp Heat (Steady State) | At 40°C, 90 to 95% R.H., For 500 hours (No voltage applied) Capacitance Change Refer to next page (*1) Dissipation Factor Initial specified value or less Leakage Current Initial specified value or less |
| Temperature Cycles | At –55°C / +125°C, 30 minutes each, For 5 cycles, Capacitance Change Refer to next page (*1) Dissipation Factor Initial specified value or less Leakage Current Initial specified value or less |
| Resistance to Soldering Heat | 10 seconds reflow at 260°C, 10 seconds immersion at 260°C Capacitance Change Refer to next page (*1) Dissipation Factor Initial specified value or less Leakage Current Initial specified value or less |
| Surge | After application of surge voltage in series with a 33Ω resistor at the rate of 30 seconds ON, 30 seconds OFF, for 1000 successive test cycles at 85°C, capacitors shall meet the characteristic requirements table below. Capacitance Change Refer to next page (*1) Dissipation Factor Initial specified value or less Leakage Current Initial specified value or less |
| Endurance | After 2000 hours' application of rated voltage at 85°C, capacitors shall meet the characteristic requirements table below. Capacitance Change Refer to next page (*1) Dissipation Factor Initial specified value or less Leakage Current Initial specified value or less |
| Shear Test | After applying the pressure load of 5N for 10±1 seconds horizontally to the center of capacitor side body which has no electrode and has been soldered beforehand on a substrate, there shall be found neither exfoliation nor its sign at the terminal electrode. 5N (0.51kg · f) For 10 ± 1 seconds |
| Terminal Strength | Keeping a capacitor surface-mounted on a substrate upside down and supporting the substrate at both of the opposite bottom points 45mm apart from the center of capacitor, the pressure strength is applied with a specified jig at the center of substrate so that the substrate may bend by 1mm as illustrated. Then, there shall be found no remarkable abnormality on the capacitor terminals. R230 45 45 1mm |

Dimensions

| Case code | L | W | H | A | B | C | (D) |
|-----------|-----------|------------|-----------|-----------|-----------|-----------|-------|
| P | 2.2 ± 0.3 | 1.25 ± 0.3 | 1.0 ± 0.2 | 0.6 ± 0.3 | 0.8 ± 0.3 | 0.8 ± 0.3 | (0.2) |
| S | 3.2 ± 0.3 | 1.6 ± 0.3 | 1.0 ± 0.2 | 0.8 ± 0.3 | 1.2 ± 0.3 | 0.8 ± 0.3 | (0.2) |
| A | 3.2 ± 0.3 | 1.7 ± 0.3 | 1.4 ± 0.2 | 0.8 ± 0.3 | 1.2 ± 0.3 | 0.8 ± 0.3 | (0.2) |
| T | 3.5 ± 0.2 | 2.7 ± 0.2 | 1.0 ± 0.2 | 0.8 ± 0.2 | 1.2 ± 0.2 | 1.1 ± 0.2 | (0.2) |
| B | 3.5 ± 0.2 | 2.8 ± 0.2 | 1.8 ± 0.2 | 0.8 ± 0.3 | 1.2 ± 0.3 | 1.1 ± 0.3 | (0.2) |

D dimension only for reference



AUDIO F95 Series



Conformal Coated Chip Optimized for Audio Applications

Standard Ratings

| Cap. (μF) | V | 4 | 6.3 | 10 |
|-----------|------|-------------|---------------|----|
| | Code | 0G | 0J | 1A |
| 68 | 686 | S | S | B |
| 100 | 107 | S | S • T | B |
| 150 | 157 | S | (A) | |
| 220 | 227 | (P) • S • T | (A) • (T) • B | |
| 330 | 337 | T | B | |
| 470 | 477 | (T) • B | (B) | |
| 680 | 687 | (T) • (B) | | |

() The series in parentheses are being developed.
Please contact to your local AVX sales office when these series are being designed in your application.

Marking

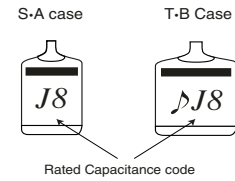

| μF code | 68 | 100 | 150 | 220 | 330 | 470 | 680 |
|---------|----|-----|-----|-----|-----|-----|-----|
| | W7 | A8 | E8 | J8 | N8 | S8 | W8 |

P case - No marking on part.

Standard Ratings

| Rated Volt | Rated Capacitance (μF) | Case code | Part Number | *2 Leakage Current (μA) | Dissipation Factor (% @ 120Hz) | ESR (Ω @ 100kHz) | *1 ΔC/C (%) |
|------------|------------------------|-----------|------------------|-------------------------|--------------------------------|------------------|-------------|
| 4V | 68 | S | F950G686MSAAM1Q2 | 2.7 | 10 | 0.8 | * |
| | 100 | S | F950G107MSAAM1Q2 | 4.0 | 14 | 0.8 | * |
| | 150 | S | F950G157MSAAM1Q2 | 6.0 | 22 | 0.8 | ±15 |
| | 220 | S | F950G227MSAAM1Q2 | 8.8 | 30 | 0.8 | ±15 |
| | 220 | T | F950G227MTAAM1Q2 | 8.8 | 25 | 0.6 | * |
| | 330 | T | F950G337MTAAM1Q2 | 13.2 | 40 | 0.8 | ±20 |
| | 470 | B | F950G477MBAAM1Q2 | 18.8 | 40 | 0.4 | ±20 |
| 6.3V | 68 | S | F950J686MSAAM1Q2 | 4.3 | 14 | 0.9 | * |
| | 100 | S | F950J107MSAAM1Q2 | 6.3 | 20 | 0.9 | ±15 |
| | 100 | T | F950J107MTAAM1Q2 | 6.3 | 14 | 0.6 | * |
| | 220 | B | F950J227MBAAM1Q2 | 13.9 | 30 | 0.4 | * |
| | 330 | B | F950J337MBAAM1Q2 | 20.8 | 35 | 0.6 | ±20 |
| 10V | 68 | B | F951A686MBAAM1Q2 | 6.8 | 12 | 0.4 | * |
| | 100 | B | F951A107MBAAM1Q2 | 10.0 | 14 | 0.4 | * |

* In case of capacitance tolerance ± 10% type, [K] will be put at 9th digit of type numbering system.

1 : ΔC/C Marked ""

| Item | S • A • T • B Case (%) |
|---------------------------|------------------------|
| Damp Heat | ±10 |
| Temperature cycles | ±5 |
| Resistance soldering heat | ±5 |
| Surge | ±5 |
| Endurance | ±10 |

*2 : Leakage Current

After 1 minute's application of rated voltage, leakage current at 20°C.

OxiCap® NOJ Series



Niobium Oxide Capacitor



- Non-burn safe technology
- Reliability level: 0.5%/1000 hrs.
- 6 case sizes available
- Environmentally friendly
- IBM global approval received in 2004
- Electra Award received in 2005
- CV range: 4.7-1000 μ F / 1.8-10V



Electra Award
2005

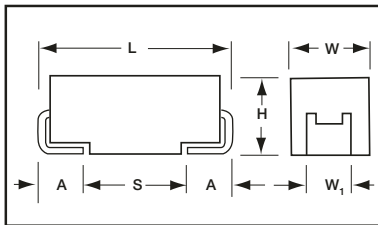

For part marking see page 151

CASE DIMENSIONS: millimeters (inches)

| Code | EIA Code | EIA Metric | L \pm 0.20 (0.008) | W+0.20 (0.008) -0.10 (0.004) | H+0.20 (0.008) -0.10 (0.004) | W \pm 0.20 (0.008) | A+0.30 (0.012) -0.20 (0.008) | S Min. |
|------|----------|------------|----------------------|------------------------------|------------------------------|----------------------|------------------------------|--------------|
| A | 1206 | 3216-18 | 3.20 (0.126) | 1.60 (0.063) | 1.60 (0.063) | 1.20 (0.047) | 0.80 (0.031) | 1.10 (0.043) |
| B | 1210 | 3528-21 | 3.50 (0.138) | 2.80 (0.110) | 1.90 (0.075) | 2.20 (0.087) | 0.80 (0.031) | 1.40 (0.055) |
| C | 2312 | 6032-28 | 6.00 (0.236) | 3.20 (0.126) | 2.60 (0.102) | 2.20 (0.087) | 1.30 (0.051) | 2.90 (0.114) |
| D | 2917 | 7343-31 | 7.30 (0.287) | 4.30 (0.169) | 2.90 (0.114) | 2.40 (0.094) | 1.30 (0.051) | 4.40 (0.173) |
| E | 2917 | 7343-43 | 7.30 (0.287) | 4.30 (0.169) | 4.10 (0.162) | 2.40 (0.094) | 1.30 (0.051) | 4.40 (0.173) |
| V | 2924 | 7361-38 | 7.30 (0.287) | 6.10 (0.240) | 3.55 (0.140) | 3.10 (0.120) | 1.30 (0.051) | 4.40 (0.173) |

W₁ dimension applies to the termination width for A dimensional area only.

HOW TO ORDER

| | | | | | | | |
|-------------|-------------------------------------|--|----------------------------|--|---|---|---|
| NOJ | D | 107 | M | 006 | R | WJ | - |
| Type | Case Size See table above | Capacitance Code 1st two digits represent significant figures, 3rd digit represents multiplier in pF | Tolerance M=±20% | Rated DC Voltage 001 = 1.8Vdc 002 = 2.5Vdc 004 = 4Vdc 006 = 6.3Vdc 010 = 10Vdc | Packaging R = Pure Tin 7" Reel S = Pure Tin 13" Reel | Specification Suffix WJ = Standard Suffix | Additional characters may be added for special requirements V = Dry pack Option (selected codes only) with exception of D, E, V cases |

TECHNICAL SPECIFICATIONS

| | | | | | | | |
|------------------------------------|--|-----|-----|-----|-----|----|--|
| Technical Data: | All technical data relate to an ambient temperature of +25°C is not stated | | | | | | |
| Capacitance Range: | 4.7 μ F to 1000 μ F | | | | | | |
| Capacitance Tolerance: | ±20% | | | | | | |
| Leakage Current DCL: | 0.02CV | | | | | | |
| Rated Voltage DC (V _R) | ≤ +85°C: | 1.8 | 2.5 | 4 | 6.3 | 10 | |
| Category Voltage (V _C) | ≤ +105°C: | 1.2 | 1.7 | 2.7 | 4 | 7 | |
| Surge Voltage (V _S) | ≤ +85°C: | 2.3 | 3.3 | 5.2 | 8 | 13 | |
| Surge Voltage (V _S) | ≤ +105°C: | 1.6 | 2.2 | 3.4 | 5 | 8 | |
| Temperature Range: | -55°C to +105°C | | | | | | |
| Reliability: | 0.5% per 1000 hours at 85°C, V _R , 0.1 Ω /V series impedance, 60% confidence level Meets requirements of AEC-Q200 | | | | | | |



OxiCap® NOJ Series



Niobium Oxide Capacitor

CAPACITANCE AND RATED VOLTAGE RANGE (LETTER DENOTES CASE SIZE)

| Capacitance | | Rated Voltage DC (V _R) to 85°C / 0.66 DC to 105°C | | | | |
|-------------|------|---|----------|------------|--------------|------------|
| μF | Code | 1.8V (x) | 2.5V (e) | 4V (G) | 6.3V (J) | 10V (A) |
| 4.7 | 475 | | | | A | A |
| 6.8 | 685 | | | | A | A |
| 10 | 106 | | | | A | A/B |
| 15 | 156 | | | A | A/B | A/B |
| 22 | 226 | | A | A/B | A/B | B/C/B(700) |
| 33 | 336 | | A/B | A/B | B/C/B(700) | C |
| 47 | 476 | A | A/B | A/B/C | B/C | C |
| 68 | 686 | B | B/C | B/C | B/C | C |
| 100 | 107 | B/C | B/C | B/C/B(250) | B/C/D/B(400) | D/D(150) |
| 150 | 157 | C | C | C/D | C/D | |
| 220 | 227 | C | C | C/D | C/D/E | V |
| 330 | 337 | C | C/D | D | D/E | |
| 470 | 477 | | D/E | D/E | E/V | |
| 680 | 687 | | E | E/V | | |
| 1000 | 108 | | V | V | | |

Released codes

Engineering samples - please contact manufacturer

*Codes under development - subject to change

Note: Voltage ratings are minimum values. AVX reserves the right to supply higher ratings in the same case size, to the same reliability standards.



LEAD-FREE

LEAD-FREE COMPATIBLE
COMPONENT



RoHS
COMPLIANT



NON-BURN
NON-SMOKE

OxiCap[®] NOJ Series



Niobium Oxide Capacitor

RATINGS & PART NUMBER REFERENCE

| AVX Part No. | Case Size | Capacitance (µF) | Rated Voltage (V) | DCL (µA) Max. | DF % Max. | ESR Max. (Ω) @100kHz | MSL | 100kHz RMS Current (A) | | | 100kHz RMS Voltage (V) | | |
|---|-----------|------------------|-------------------|---------------|-----------|----------------------|-----|------------------------|-------|-------|------------------------|-------|-------|
| | | | | | | | | 25°C | 85°C | 105°C | 25°C | 85°C | 105°C |
| 1.8 Volt @ 85°C (1.2 Volt @ 105°C) | | | | | | | | | | | | | |
| NOJA476M001#WJ | A | 47 | 1.8 | 1.7 | 8 | 1.6 | 1 | 0.237 | 0.213 | 0.095 | 0.379 | 0.342 | 0.152 |
| NOJB476M001#WJ | B | 47 | 1.8 | 1.7 | 6 | 1.6 | 1 | 0.252 | 0.227 | 0.101 | 0.404 | 0.364 | 0.162 |
| NOJB686M001#WJ | B | 68 | 1.8 | 2.5 | 6 | 1.5 | 1 | 0.261 | 0.235 | 0.104 | 0.391 | 0.352 | 0.156 |
| NOJB107M001#WJ | B | 100 | 1.8 | 3.6 | 6 | 1.4 | 1 | 0.270 | 0.243 | 0.108 | 0.378 | 0.340 | 0.151 |
| NOJC107M001#WJ | C | 100 | 1.8 | 3.6 | 6 | 0.4 | 1 | 0.574 | 0.517 | 0.230 | 0.230 | 0.207 | 0.092 |
| NOJC157M001#WJ | C | 150 | 1.8 | 5.4 | 8 | 0.4 | 1 | 0.574 | 0.517 | 0.230 | 0.230 | 0.207 | 0.092 |
| NOJC227M001#WJ | C | 220 | 1.8 | 8.0 | 8 | 0.4 | 1 | 0.574 | 0.517 | 0.230 | 0.230 | 0.207 | 0.092 |
| NOJC337M001#WJ | C | 330 | 1.8 | 11.9 | 8 | 0.3 | 1 | 0.663 | 0.597 | 0.265 | 0.199 | 0.179 | 0.080 |
| 2.5 Volt @ 85°C (1.7 Volt @ 105°C) | | | | | | | | | | | | | |
| NOJA226M002#WJ | A | 22 | 2.5 | 1.1 | 6 | 1.9 | 1 | 0.218 | 0.196 | 0.087 | 0.414 | 0.372 | 0.165 |
| NOJA336M002#WJ | A | 33 | 2.5 | 1.7 | 6 | 1.7 | 1 | 0.230 | 0.207 | 0.092 | 0.391 | 0.352 | 0.156 |
| NOJB336M002#WJ | B | 33 | 2.5 | 1.7 | 6 | 1.7 | 1 | 0.245 | 0.220 | 0.098 | 0.416 | 0.375 | 0.167 |
| NOJA476M002#WJ | A | 47 | 2.5 | 2.4 | 8 | 1.6 | 1 | 0.237 | 0.213 | 0.095 | 0.379 | 0.342 | 0.152 |
| NOJB476M002#WJ | B | 47 | 2.5 | 2.4 | 6 | 1.6 | 1 | 0.252 | 0.227 | 0.101 | 0.404 | 0.364 | 0.162 |
| NOJB686M002#WJ | B | 68 | 2.5 | 3.4 | 6 | 1.5 | 1 | 0.261 | 0.235 | 0.104 | 0.391 | 0.352 | 0.156 |
| NOJC686M002#WJ | C | 68 | 2.5 | 3.4 | 6 | 0.5 | 1 | 0.514 | 0.462 | 0.206 | 0.257 | 0.231 | 0.103 |
| NOJB107M002#WJ | B | 100 | 2.5 | 5.0 | 6 | 1.4 | 1 | 0.270 | 0.243 | 0.108 | 0.378 | 0.340 | 0.151 |
| NOJC107M002#WJ | C | 100 | 2.5 | 5.0 | 6 | 0.4 | 1 | 0.574 | 0.517 | 0.230 | 0.230 | 0.207 | 0.092 |
| NOJC157M002#WJ | C | 150 | 2.5 | 7.5 | 6 | 0.4 | 1 | 0.574 | 0.517 | 0.230 | 0.230 | 0.207 | 0.092 |
| NOJC227M002#WJ | C | 220 | 2.5 | 11.0 | 8 | 0.4 | 1 | 0.574 | 0.517 | 0.230 | 0.230 | 0.207 | 0.092 |
| NOJC337M002#WJ | C | 330 | 2.5 | 16.5 | 10 | 0.3 | 1 | 0.663 | 0.597 | 0.265 | 0.199 | 0.179 | 0.080 |
| NOJD337M002#WJ | D | 330 | 2.5 | 16.5 | 10 | 0.3 | 3 | 0.775 | 0.697 | 0.310 | 0.232 | 0.209 | 0.093 |
| NOJD477M002#WJ | D | 470 | 2.5 | 23.5 | 12 | 0.3 | 3 | 0.775 | 0.697 | 0.310 | 0.323 | 0.209 | 0.093 |
| NOJE477M002#WJ | E | 470 | 2.5 | 23.5 | 10 | 0.3 | 3 | 0.812 | 0.731 | 0.325 | 0.244 | 0.219 | 0.097 |
| NOJE687M002#WJ | E | 680 | 2.5 | 34.0 | 14 | 0.3 | 3 | 0.812 | 0.731 | 0.325 | 0.244 | 0.219 | 0.097 |
| NOJV108M002#WJ | V | 1000 | 2.5 | 50.0 | 16 | 0.3 | 3 | 1.000 | 0.900 | 0.400 | 0.300 | 0.270 | 0.120 |
| 4 Volt @ 85°C (2.7 Volt @ 105°C) | | | | | | | | | | | | | |
| NOJA156M004#WJ | A | 15 | 4 | 1.2 | 6 | 2 | 1 | 0.212 | 0.191 | 0.085 | 0.424 | 0.382 | 0.170 |
| NOJA226M004#WJ | A | 22 | 4 | 1.8 | 6 | 1.9 | 1 | 0.218 | 0.196 | 0.087 | 0.414 | 0.372 | 0.165 |
| NOJB226M004#WJ | B | 22 | 4 | 1.8 | 6 | 1.9 | 1 | 0.232 | 0.209 | 0.093 | 0.440 | 0.396 | 0.176 |
| NOJA336M004#WJ | A | 33 | 4 | 2.6 | 10 | 1.7 | 1 | 0.230 | 0.207 | 0.092 | 0.391 | 0.352 | 0.156 |
| NOJB336M004#WJ | B | 33 | 4 | 2.6 | 6 | 1.7 | 1 | 0.245 | 0.220 | 0.098 | 0.416 | 0.375 | 0.167 |
| NOJA476M004#WJ | A | 47 | 4 | 3.8 | 18 | 2.2 | 1 | 0.202 | 0.182 | 0.081 | 0.445 | 0.400 | 0.178 |
| NOJB476M004#WJ | B | 47 | 4 | 3.8 | 6 | 1.6 | 1 | 0.252 | 0.227 | 0.101 | 0.404 | 0.364 | 0.162 |
| NOJC476M004#WJ | C | 47 | 4 | 3.8 | 6 | 0.5 | 1 | 0.514 | 0.462 | 0.206 | 0.257 | 0.231 | 0.103 |
| NOJB686M004#WJ | B | 68 | 4 | 5.4 | 6 | 1.5 | 1 | 0.261 | 0.235 | 0.104 | 0.391 | 0.352 | 0.156 |
| NOJC686M004#WJ | C | 68 | 4 | 5.4 | 6 | 0.5 | 1 | 0.514 | 0.462 | 0.206 | 0.257 | 0.231 | 0.103 |
| NOJB107M004#WJ | B | 100 | 4 | 8.0 | 16 | 1.4 | 1 | 0.270 | 0.243 | 0.108 | 0.378 | 0.340 | 0.151 |
| NOJB107M004#WB | B | 100 | 4 | 8.0 | 16 | 0.25 | 3 | 0.639 | 0.575 | 0.255 | 0.160 | 0.144 | 0.064 |
| NOJC107M004#WJ | C | 100 | 4 | 8.0 | 6 | 0.4 | 1 | 0.574 | 0.517 | 0.230 | 0.230 | 0.207 | 0.092 |
| NOJC157M004#WJ | C | 150 | 4 | 12.0 | 6 | 0.4 | 1 | 0.574 | 0.517 | 0.230 | 0.230 | 0.207 | 0.092 |
| NOJD157M004#WJ | D | 150 | 4 | 12.0 | 6 | 0.3 | 3 | 0.775 | 0.697 | 0.310 | 0.232 | 0.209 | 0.093 |
| NOJC227M004#WJ | C | 220 | 4 | 17.6 | 8 | 0.4 | 1 | 0.574 | 0.517 | 0.230 | 0.230 | 0.207 | 0.092 |
| NOJD227M004#WJ | D | 220 | 4 | 17.6 | 8 | 0.4 | 3 | 0.671 | 0.604 | 0.268 | 0.268 | 0.241 | 0.107 |
| NOJD337M004#WJ | D | 330 | 4 | 26.4 | 8 | 0.3 | 3 | 0.775 | 0.697 | 0.310 | 0.232 | 0.209 | 0.093 |
| NOJD477M004#WJ | D | 470 | 4 | 37.6 | 12 | 0.3 | 3 | 0.775 | 0.697 | 0.310 | 0.232 | 0.209 | 0.093 |
| NOJE477M004#WJ | E | 470 | 4 | 37.6 | 12 | 0.3 | 3 | 0.812 | 0.731 | 0.325 | 0.244 | 0.219 | 0.097 |
| NOJE687M004#WJ | E | 680 | 4 | 54.4 | 14 | 0.3 | 3 | 0.812 | 0.731 | 0.325 | 0.244 | 0.219 | 0.097 |
| NOJV687M004#WJ | V | 680 | 4 | 54.4 | 14 | 0.3 | 3 | 1.000 | 0.900 | 0.400 | 0.300 | 0.270 | 0.120 |
| NOJV108M004#WJ | V | 1000 | 4 | 80.0 | 18 | 0.3 | 3 | 1.000 | 0.900 | 0.400 | 0.300 | 0.270 | 0.120 |
| 6.3 Volt @ 85°C (4 Volt @ 105°C) | | | | | | | | | | | | | |
| NOJA475M006#WJ | A | 4.7 | 6.3 | 1.1 | 6 | 3.2 | 1 | 0.168 | 0.151 | 0.067 | 0.537 | 0.483 | 0.215 |
| NOJA685M006#WJ | A | 6.8 | 6.3 | 1.1 | 6 | 2.6 | 1 | 0.186 | 0.167 | 0.074 | 0.484 | 0.435 | 0.193 |
| NOJA106M006#WJ | A | 10 | 6.3 | 1.2 | 6 | 2.2 | 1 | 0.202 | 0.182 | 0.081 | 0.445 | 0.400 | 0.178 |
| NOJA156M006#WJ | A | 15 | 6.3 | 1.8 | 8 | 2 | 1 | 0.212 | 0.191 | 0.085 | 0.424 | 0.382 | 0.170 |
| NOJB156M006#WJ | B | 15 | 6.3 | 1.8 | 6 | 2 | 1 | 0.226 | 0.203 | 0.090 | 0.452 | 0.406 | 0.181 |
| NOJA226M006#WJ | A | 22 | 6.3 | 2.6 | 8 | 1.8 | 1 | 0.224 | 0.201 | 0.089 | 0.402 | 0.362 | 0.161 |
| NOJB226M006#WJ | B | 22 | 6.3 | 2.6 | 6 | 1.9 | 1 | 0.232 | 0.209 | 0.093 | 0.440 | 0.396 | 0.176 |
| NOJB336M006#WJ | B | 33 | 6.3 | 4.0 | 6 | 1.7 | 1 | 0.245 | 0.220 | 0.098 | 0.416 | 0.375 | 0.167 |

Moisture Sensitivity Level (MSL) is defined according to J-STD-020.

All technical data relates to an ambient temperature of +25°C. Capacitance and DF are measured at 120Hz, 0.5V RMS with a maximum DC bias of 2.2 volts. DCL is measured at rated voltage after 5 minutes.

For typical weight and composition see page 144.

NOTE: AVX reserves the right to supply a higher voltage rating or tighter tolerance part in the same case size, to the same reliability standards.



OxiCap® NOJ Series



Niobium Oxide Capacitor

RATINGS & PART NUMBER REFERENCE

| AVX Part No. | Case Size | Capacitance (µF) | Rated Voltage (V) | DCL (µA) Max. | DF % Max. | ESR Max. (Ω) @100kHz | MSL | 100kHz RMS Current (A) | | | 100kHz RMS Voltage (V) | | |
|---|-----------|------------------|-------------------|---------------|-----------|----------------------|-----|------------------------|-------|-------|------------------------|-------|-------|
| | | | | | | | | 25°C | 85°C | 105°C | 25°C | 85°C | 105°C |
| 6.3 Volt @ 85°C (4 Volt @ 105°C) | | | | | | | | | | | | | |
| NOJB336M006#WB | B | 33 | 6.3 | 4.0 | 6 | 0.7 | 3 | 0.382 | 0.344 | 0.153 | 0.267 | 0.240 | 0.107 |
| NOJC336M006#WJ | C | 33 | 6.3 | 4.0 | 6 | 0.5 | 1 | 0.514 | 0.462 | 0.206 | 0.257 | 0.231 | 0.103 |
| NOJB476M006#WJ | B | 47 | 6.3 | 5.6 | 6 | 0.8 | 1 | 0.357 | 0.321 | 0.143 | 0.286 | 0.257 | 0.114 |
| NOJC476M006#WJ | C | 47 | 6.3 | 5.7 | 6 | 0.5 | 1 | 0.514 | 0.462 | 0.206 | 0.257 | 0.231 | 0.103 |
| NOJB686M006#WJ | B | 68 | 6.3 | 8.2 | 20 | 1.5 | 1 | 0.261 | 0.235 | 0.104 | 0.391 | 0.352 | 0.156 |
| NOJC686M006#WJ | C | 68 | 6.3 | 8.2 | 6 | 0.5 | 1 | 0.514 | 0.462 | 0.206 | 0.257 | 0.231 | 0.103 |
| NOJB107M006#WJ | B | 100 | 6.3 | 60.0 | 20 | 1.7 | 1 | 0.245 | 0.220 | 0.098 | 0.416 | 0.375 | 0.167 |
| NOJB107M006#WB | B | 100 | 6.3 | 60.0 | 20 | 0.4 | 3 | 0.505 | 0.454 | 0.202 | 0.202 | 0.182 | 0.081 |
| NOJC107M006#WJ | C | 100 | 6.3 | 12.0 | 8 | 0.4 | 1 | 0.574 | 0.517 | 0.230 | 0.230 | 0.207 | 0.092 |
| NOJD107M006#WJ | D | 100 | 6.3 | 12.0 | 6 | 0.4 | 3 | 0.671 | 0.604 | 0.268 | 0.268 | 0.241 | 0.107 |
| NOJC157M006#WJ | C | 150 | 6.3 | 18.0 | 6 | 0.4 | 1 | 0.574 | 0.517 | 0.230 | 0.230 | 0.207 | 0.092 |
| NOJD157M006#WJ | D | 150 | 6.3 | 18.0 | 6 | 0.4 | 3 | 0.671 | 0.604 | 0.268 | 0.268 | 0.241 | 0.107 |
| NOJC227M006#WJ | C | 220 | 6.3 | 26.4 | 14 | 0.4 | 1 | 0.574 | 0.517 | 0.230 | 0.230 | 0.207 | 0.092 |
| NOJD227M006#WJ | D | 220 | 6.3 | 26.4 | 8 | 0.4 | 3 | 0.671 | 0.604 | 0.268 | 0.268 | 0.241 | 0.107 |
| NOJE227M006#WJ | E | 220 | 6.3 | 26.4 | 12 | 0.4 | 3 | 0.704 | 0.633 | 0.281 | 0.281 | 0.253 | 0.113 |
| NOJD337M006#WJ | D | 330 | 6.3 | 39.6 | 10 | 0.3 | 3 | 0.775 | 0.697 | 0.310 | 0.232 | 0.209 | 0.093 |
| NOJE337M006#WJ | E | 330 | 6.3 | 39.6 | 12 | 0.3 | 3 | 0.812 | 0.731 | 0.325 | 0.244 | 0.219 | 0.097 |
| NOJE477M006#WJ | E | 470 | 6.3 | 56.4 | 16 | 0.3 | 3 | 0.812 | 0.731 | 0.325 | 0.244 | 0.219 | 0.097 |
| NOJV477M006#WJ | V | 470 | 6.3 | 56.4 | 14 | 0.3 | 3 | 1.000 | 0.900 | 0.400 | 0.300 | 0.270 | 0.120 |
| 10 Volt @ 85°C (7 Volt @ 105°C) | | | | | | | | | | | | | |
| NOJA475M010#WJ | A | 4.7 | 10 | 1.0 | 6 | 3.1 | 1 | 0.170 | 0.153 | 0.068 | 0.528 | 0.475 | 0.211 |
| NOJA685M010#WJ | A | 6.8 | 10 | 1.4 | 6 | 2.6 | 1 | 0.186 | 0.167 | 0.074 | 0.484 | 0.435 | 0.193 |
| NOJA106M010#WJ | A | 10 | 10 | 2.0 | 6 | 2.2 | 1 | 0.202 | 0.182 | 0.081 | 0.445 | 0.400 | 0.178 |
| NOJB106M010#WJ | B | 10 | 10 | 2.0 | 6 | 1 | 1 | 0.319 | 0.287 | 0.128 | 0.319 | 0.287 | 0.128 |
| NOJA156M010#WJ | A | 15 | 10 | 3.0 | 6 | 2 | 1 | 0.212 | 0.191 | 0.085 | 0.424 | 0.382 | 0.170 |
| NOJB156M010#WJ | B | 15 | 10 | 3.0 | 6 | 2 | 1 | 0.226 | 0.203 | 0.090 | 0.452 | 0.406 | 0.181 |
| NOJB226M010#WJ | B | 22 | 10 | 4.4 | 6 | 1.8 | 1 | 0.238 | 0.214 | 0.095 | 0.428 | 0.386 | 0.171 |
| NOJB226M010#WB | B | 22 | 10 | 4.4 | 6 | 0.7 | 3 | 0.382 | 0.344 | 0.153 | 0.267 | 0.240 | 0.107 |
| NOJC226M010#WJ | C | 22 | 10 | 4.4 | 6 | 0.5 | 1 | 0.514 | 0.462 | 0.206 | 0.257 | 0.231 | 0.103 |
| NOJC336M010#WJ | C | 33 | 10 | 6.6 | 6 | 0.5 | 1 | 0.514 | 0.462 | 0.206 | 0.257 | 0.231 | 0.103 |
| NOJC476M010#WJ | C | 47 | 10 | 9.4 | 6 | 0.4 | 1 | 0.574 | 0.517 | 0.230 | 0.230 | 0.207 | 0.092 |
| NOJC686M010#WJ | C | 68 | 10 | 13.6 | 12 | 0.5 | 1 | 0.514 | 0.462 | 0.206 | 0.257 | 0.231 | 0.103 |
| NOJD107M010#WJ | D | 100 | 10 | 20.0 | 12 | 0.4 | 3 | 0.671 | 0.604 | 0.268 | 0.268 | 0.241 | 0.107 |
| NOJD107M010#WB | D | 100 | 10 | 20.0 | 12 | 0.15 | 3 | 1.095 | 0.986 | 0.438 | 0.164 | 0.148 | 0.066 |
| NOJV227M010#WJ | V | 220 | 10 | 44.0 | 12 | 0.4 | 3 | 0.866 | 0.779 | 0.346 | 0.364 | 0.312 | 0.139 |

Moisture Sensitivity Level (MSL) is defined according to J-STD-020.

All technical data relates to an ambient temperature of +25°C. Capacitance and DF are measured at 120Hz, 0.5V RMS with a maximum DC bias of 2.2 volts. DCL is measured at rated voltage after 5 minutes.

The EIA & CECC standards for capacitors allow an ESR movement to 1.25 times catalog limit post mounting.

For typical weight and composition see page 144.

NOTE: AVX reserves the right to supply a higher voltage rating or tighter tolerance part in the same case size, to the same reliability standards.

OxiCap® NOJ Series



Low Profile

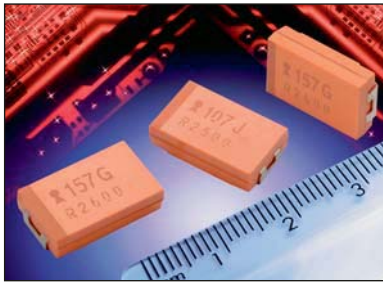

- Non-burn safe technology
- Reliability level: 0.5%/1000 hrs.
- CV range: 2.2-470µF / 1.8-10V
- 7 case sizes in low profile available
- IBM global approval received in 2004
- Electra Award received in 2005



Electra Award
2005

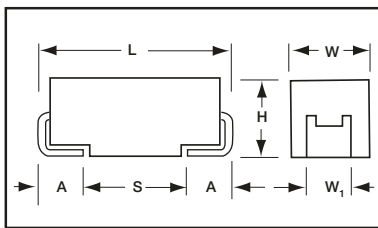

For part marking see page 151

CASE DIMENSIONS: millimeters (inches)

| Code | EIA Code | EIA Metric | L±0.20 (0.008) | W+0.20 (0.008) -0.10 (0.004) | H Max | W ₁ ±0.20 (0.008) | A+0.30 (0.012) -0.20 (0.008) | S Min. |
|------|----------|------------|----------------|------------------------------|--------------|------------------------------|------------------------------|--------------|
| F | 2312 | 6032-20 | 6.00 (0.236) | 3.20 (0.126) | 2.00 (0.079) | 2.20 (0.087) | 1.30 (0.051) | 2.90 (0.114) |
| P | 0805 | 2012-15 | 2.05 (0.081) | 1.35 (0.053) | 1.50 (0.059) | 1.00±0.10 (0.039±0.004) | 0.50 (0.020) | 0.85 (0.033) |
| S | 1206 | 3216-12 | 3.20 (0.126) | 1.60 (0.063) | 1.20 (0.047) | 1.20 (0.047) | 0.80 (0.031) | 1.10 (0.043) |
| T | 1210 | 3528-12 | 3.50 (0.138) | 2.80 (0.110) | 1.20 (0.047) | 2.20 (0.087) | 0.80 (0.031) | 1.40 (0.055) |
| W | 2312 | 6032-15 | 6.00 (0.236) | 3.20 (0.126) | 1.50 (0.059) | 2.20 (0.087) | 1.30 (0.051) | 2.90 (0.114) |
| X | 2917 | 7343-15 | 7.30 (0.287) | 4.30 (0.169) | 1.50 (0.059) | 2.40 (0.094) | 1.30 (0.051) | 4.40 (0.173) |
| Y | 2917 | 7343-20 | 7.30 (0.287) | 4.30 (0.169) | 2.00 (0.079) | 2.40 (0.094) | 1.30 (0.051) | 4.40 (0.173) |

W₁ dimension applies to the termination width for A dimensional area only.
Pad Stand-off is 0.1±0.1.

HOW TO ORDER

NOJ



Type

Y



Case Size
See table above

107



Capacitance Code
1st two digits represent significant figures, 3rd digit represents multiplier in pF

M



Tolerance
M=±20%

006



Rated DC Voltage
001 = 1.8Vdc
002 = 2.5Vdc
004 = 4Vdc
006 = 6.3Vdc
010 = 10Vdc

R



Packaging
R = Pure Tin 7" Reel
S = Pure Tin 13" Reel

WJ



Specification Suffix
WJ = Standard Suffix

-



Additional characters may be added for special requirements
V = Dry pack Option (selected codes only) with exception of X, Y cases

TECHNICAL SPECIFICATIONS

Technical Data:

All technical data relate to an ambient temperature of +25°C is not stated

Capacitance Range: 2.2 µF to 470 µF

Capacitance Tolerance: ±20%

Leakage Current DCL: 0.02CV

| Rated Voltage DC (V _R) | ≤ +85°C: | 1.8 | 2.5 | 4 | 6.3 | 10 | |
|------------------------------------|-----------|-----|-----|-----|-----|----|--|
| Category Voltage (V _C) | ≤ +105°C: | 1.2 | 1.7 | 2.7 | 4 | 7 | |
| Surge Voltage (V _S) | ≤ +85°C: | 2.3 | 3.3 | 5.2 | 8 | 13 | |
| Surge Voltage (V _S) | ≤ +105°C: | 1.6 | 2.2 | 3.4 | 5 | 8 | |

Temperature Range: -55°C to +105°C

Reliability: 0.5% per 1000 hours at 85°C, V_R, 0.1Ω/V series impedance, 60% confidence level

Meets requirements of AEC-Q200



OxiCap® NOJ Series



Low Profile

CAPACITANCE AND RATED VOLTAGE RANGE (LETTER DENOTES CASE SIZE)

| Capacitance | | Rated Voltage DC (V _R) to 85°C / 0.66 DC to 105°C | | | | |
|-------------|------|---|----------|--------|----------|---------|
| µF | Code | 1.8V (x) | 2.5V (e) | 4V (G) | 6.3V (J) | 10V (A) |
| 1.0 | 105 | | | | | |
| 1.5 | 155 | | | | | |
| 2.2 | 225 | | | | | P |
| 3.3 | 335 | | | | | P |
| 4.7 | 475 | | | | P/S | T |
| 6.8 | 685 | | | P/S | P/S/T | T |
| 10 | 106 | | P/S | P/S/T | P/T | T |
| 15 | 156 | P/S | P/S/T | P/T | | |
| 22 | 226 | P/S/T | P/T | T | T | |
| 33 | 336 | T | T | T | W | |
| 47 | 476 | T | T | W | W | |
| 68 | 686 | | W | W | X/Y | |
| 100 | 107 | W | W | W/X | F/Y | |
| 150 | 157 | | X | Y | F/Y | |
| 220 | 227 | X | Y | F/Y | Y | |
| 330 | 337 | Y | Y | Y | | |
| 470 | 477 | Y | | | | |

Released codes

Engineering samples - please contact manufacturer

*Codes under development - subject to change

Note: Voltage ratings are minimum values. AVX reserves the right to supply higher ratings in the same case size, to the same reliability standards.



LEAD-FREE

LEAD-FREE COMPATIBLE
COMPONENT



RoHS
COMPLIANT



NON-BURN
NON-SMOKE

Low Profile

RATINGS & PART NUMBER REFERENCE

| AVX Part No. | Case Size | Capacitance (µF) | Rated Voltage (V) | DCL (µA) Max. | DF % Max. | ESR Max. (Ω) @100kHz | MSL | 100kHz RMS Current (A) | | | 100kHz RMS Voltage (V) | | |
|---|-----------|------------------|-------------------|---------------|-----------|----------------------|-----|------------------------|-------|-------|------------------------|-------|-------|
| | | | | | | | | 25°C | 85°C | 125°C | 25°C | 85°C | 125°C |
| 1.8 Volt @ 85°C (1.2 Volt @ 105°C) | | | | | | | | | | | | | |
| NOJP156M001#WJ | P | 15 | 1.8 | 1.0 | 10 | 4.1 | 1 | 0.133 | 0.119 | 0.053 | 0.543 | 0.489 | 0.217 |
| NOJS156M001#WJ | S | 15 | 1.8 | 1.0 | 6 | 2 | 1 | 0.197 | 0.178 | 0.079 | 0.395 | 0.335 | 0.158 |
| NOJP226M001#WJ | P | 22 | 1.8 | 1.0 | 10 | 3.8 | 1 | 0.138 | 0.124 | 0.055 | 0.523 | 0.471 | 0.209 |
| NOJS226M001#WJ | S | 22 | 1.8 | 1.0 | 8 | 1.9 | 1 | 0.203 | 0.182 | 0.081 | 0.385 | 0.346 | 0.154 |
| NOJT226M001#WJ | T | 22 | 1.8 | 1.0 | 6 | 1.8 | 1 | 0.231 | 0.208 | 0.092 | 0.416 | 0.374 | 0.166 |
| NOJT336M001#WJ | T | 33 | 1.8 | 1.2 | 6 | 1.7 | 1 | 0.238 | 0.214 | 0.095 | 0.404 | 0.364 | 0.162 |
| NOJT476M001#WJ | T | 47 | 1.8 | 1.7 | 10 | 1.6 | 1 | 0.245 | 0.220 | 0.098 | 0.392 | 0.353 | 0.157 |
| NOJW107M001#WJ | W | 100 | 1.8 | 3.6 | 6 | 0.4 | 1 | 0.520 | 0.468 | 0.208 | 0.208 | 0.187 | 0.083 |
| NOJX227M001#WJ | X | 220 | 1.8 | 8.0 | 8 | 0.4 | 3 | 0.548 | 0.493 | 0.219 | 0.219 | 0.197 | 0.088 |
| NOJY337M001#WJ | Y | 330 | 1.8 | 11.9 | 8 | 0.3 | 3 | 0.707 | 0.636 | 0.283 | 0.212 | 0.191 | 0.085 |
| NOJY477M001#WJ | Y | 470 | 1.8 | 17.0 | 8 | 0.3 | 3 | 0.707 | 0.636 | 0.283 | 0.212 | 0.191 | 0.085 |
| 2.5 Volt @ 85°C (1.7 Volt @ 105°C) | | | | | | | | | | | | | |
| NOJP106M002#WJ | P | 10 | 2.5 | 1.0 | 6 | 4.5 | 1 | 0.126 | 0.114 | 0.051 | 0.569 | 0.512 | 0.228 |
| NOJS106M002#WJ | S | 10 | 2.5 | 1.0 | 6 | 2.2 | 1 | 0.188 | 0.169 | 0.075 | 0.414 | 0.373 | 0.166 |
| NOJP156M002#WJ | P | 15 | 2.5 | 1.0 | 6 | 4 | 1 | 0.134 | 0.121 | 0.054 | 0.537 | 0.483 | 0.215 |
| NOJS156M002#WJ | S | 15 | 2.5 | 1.0 | 8 | 2 | 1 | 0.197 | 0.178 | 0.079 | 0.395 | 0.355 | 0.158 |
| NOJT156M002#WJ | T | 15 | 2.5 | 1.0 | 6 | 2 | 1 | 0.219 | 0.197 | 0.088 | 0.438 | 0.394 | 0.175 |
| NOJP226M002#WJ | P | 22 | 2.5 | 1.1 | 10 | 3.8 | 1 | 0.138 | 0.124 | 0.055 | 0.523 | 0.471 | 0.209 |
| NOJT226M002#WJ | T | 22 | 2.5 | 1.1 | 6 | 1.9 | 1 | 0.225 | 0.202 | 0.090 | 0.427 | 0.384 | 0.171 |
| NOJT336M002#WJ | T | 33 | 2.5 | 1.7 | 6 | 1.7 | 1 | 0.238 | 0.214 | 0.095 | 0.404 | 0.364 | 0.162 |
| NOJT476M002#WJ | T | 47 | 2.5 | 2.4 | 10 | 1.6 | 1 | 0.245 | 0.220 | 0.098 | 0.392 | 0.353 | 0.157 |
| NOJW686M002#WJ | W | 68 | 2.5 | 3.4 | 6 | 0.4 | 1 | 0.520 | 0.468 | 0.208 | 0.208 | 0.187 | 0.083 |
| NOJW107M002#WJ | W | 100 | 2.5 | 5.0 | 6 | 0.4 | 1 | 0.520 | 0.468 | 0.208 | 0.208 | 0.187 | 0.083 |
| NOJX157M002#WJ | X | 150 | 2.5 | 7.5 | 6 | 0.4 | 3 | 0.548 | 0.493 | 0.219 | 0.219 | 0.197 | 0.088 |
| NOJY227M002#WJ | Y | 220 | 2.5 | 11.0 | 8 | 0.4 | 3 | 0.612 | 0.551 | 0.245 | 0.245 | 0.220 | 0.098 |
| NOJY337M002#WJ | Y | 330 | 2.5 | 16.5 | 10 | 0.3 | 3 | 0.707 | 0.636 | 0.283 | 0.212 | 0.191 | 0.085 |
| 4 Volt @ 85°C (2.7 Volt @ 105°C) | | | | | | | | | | | | | |
| NOJP685M004#WJ | P | 6.8 | 4 | 1.0 | 6 | 5.3 | 1 | 0.117 | 0.105 | 0.047 | 0.618 | 0.556 | 0.247 |
| NOJS685M004#WJ | S | 6.8 | 4 | 1.0 | 6 | 2.6 | 1 | 0.173 | 0.156 | 0.069 | 0.450 | 0.405 | 0.180 |
| NOJP106M004#WJ | P | 10 | 4 | 1.0 | 20 | 4.5 | 1 | 0.126 | 0.114 | 0.051 | 0.569 | 0.512 | 0.228 |
| NOJS106M004#WJ | S | 10 | 4 | 1.0 | 8 | 2.2 | 1 | 0.188 | 0.169 | 0.075 | 0.414 | 0.373 | 0.166 |
| NOJT106M004#WJ | T | 10 | 4 | 1.0 | 6 | 2.2 | 1 | 0.209 | 0.188 | 0.084 | 0.460 | 0.414 | 0.184 |
| NOJP156M004#WJ | P | 15 | 4 | 1.2 | 10 | 4.1 | 1 | 0.133 | 0.119 | 0.053 | 0.543 | 0.489 | 0.217 |
| NOJT156M004#WJ | T | 15 | 4 | 1.2 | 6 | 2 | 1 | 0.219 | 0.197 | 0.088 | 0.438 | 0.394 | 0.175 |
| NOJT226M004#WJ | T | 22 | 4 | 1.8 | 6 | 1.8 | 1 | 0.231 | 0.208 | 0.092 | 0.416 | 0.374 | 0.166 |
| NOJT336M004#WJ | T | 33 | 4 | 2.6 | 14 | 2 | 1 | 0.219 | 0.197 | 0.088 | 0.438 | 0.394 | 0.175 |
| NOJW476M004#WJ | W | 47 | 4 | 3.8 | 6 | 0.5 | 1 | 0.465 | 0.418 | 0.186 | 0.232 | 0.209 | 0.093 |
| NOJW686M004#WJ | W | 68 | 4 | 5.4 | 6 | 0.4 | 1 | 0.520 | 0.468 | 0.208 | 0.208 | 0.187 | 0.083 |
| NOJW107M004#WJ | W | 100 | 4 | 8.0 | 8 | 0.4 | 1 | 0.520 | 0.468 | 0.208 | 0.208 | 0.187 | 0.083 |
| NOJX107M004#WJ | X | 100 | 4 | 8.0 | 6 | 0.4 | 3 | 0.548 | 0.493 | 0.219 | 0.219 | 0.197 | 0.088 |
| NOJY157M004#WJ | Y | 150 | 4 | 12.0 | 6 | 0.4 | 3 | 0.612 | 0.551 | 0.245 | 0.245 | 0.220 | 0.098 |
| NOJF227M004#WJ | F | 220 | 4 | 17.6 | 10 | 0.4 | 1 | 0.548 | 0.493 | 0.219 | 0.219 | 0.197 | 0.088 |
| NOJY227M004#WJ | Y | 220 | 4 | 17.6 | 10 | 0.4 | 3 | 0.612 | 0.551 | 0.245 | 0.245 | 0.220 | 0.098 |
| NOJY337M004#WJ | Y | 330 | 4 | 26.4 | 12 | 0.3 | 3 | 0.707 | 0.636 | 0.283 | 0.212 | 0.191 | 0.085 |
| 6.3 Volt @ 85°C (4 Volt @ 105°C) | | | | | | | | | | | | | |
| NOJP475M006#WJ | P | 4.7 | 6.3 | 1.0 | 6 | 6.1 | 1 | 0.109 | 0.098 | 0.043 | 0.663 | 0.596 | 0.265 |
| NOJS475M006#WJ | S | 4.7 | 6.3 | 1.0 | 6 | 3.2 | 1 | 0.156 | 0.141 | 0.062 | 0.500 | 0.450 | 0.200 |
| NOJP685M006#WJ | P | 6.8 | 6.3 | 1.0 | 10 | 5.2 | 1 | 0.118 | 0.106 | 0.047 | 0.612 | 0.551 | 0.245 |
| NOJS685M006#WJ | S | 6.8 | 6.3 | 1.0 | 8 | 2.7 | 1 | 0.170 | 0.153 | 0.068 | 0.459 | 0.413 | 0.184 |
| NOJT685M006#WJ | T | 6.8 | 6.3 | 1.0 | 6 | 2.6 | 1 | 0.192 | 0.173 | 0.077 | 0.500 | 0.450 | 0.200 |
| NOJP106M006#WJ | P | 10 | 6.3 | 1.2 | 10 | 4.5 | 1 | 0.126 | 0.114 | 0.051 | 0.569 | 0.512 | 0.228 |
| NOJT106M006#WJ | T | 10 | 6.3 | 1.2 | 6 | 2.2 | 1 | 0.209 | 0.188 | 0.084 | 0.460 | 0.414 | 0.184 |
| NOJT226M006#WJ | T | 22 | 6.3 | 2.6 | 8 | 1.8 | 1 | 0.231 | 0.208 | 0.092 | 0.416 | 0.374 | 0.166 |
| NOJW336M006#WJ | W | 33 | 6.3 | 4.0 | 6 | 0.5 | 1 | 0.465 | 0.418 | 0.186 | 0.232 | 0.209 | 0.093 |
| NOJW476M006#WJ | W | 47 | 6.3 | 5.7 | 6 | 0.5 | 1 | 0.465 | 0.418 | 0.186 | 0.232 | 0.209 | 0.093 |
| NOJX686M006#WJ | X | 68 | 6.3 | 8.2 | 6 | 0.5 | 3 | 0.490 | 0.441 | 0.196 | 0.245 | 0.220 | 0.098 |
| NOJY686M006#WJ | Y | 68 | 6.3 | 8.2 | 6 | 0.5 | 3 | 0.548 | 0.493 | 0.219 | 0.274 | 0.246 | 0.110 |
| NOJF107M006#WJ | F | 100 | 6.3 | 12 | 8 | 0.4 | 1 | 0.548 | 0.493 | 0.219 | 0.219 | 0.197 | 0.088 |
| NOJY107M006#WJ | Y | 100 | 6.3 | 12.0 | 6 | 0.4 | 3 | 0.612 | 0.551 | 0.245 | 0.245 | 0.220 | 0.098 |
| NOJF157M006#WJ | F | 150 | 6.3 | 18.0 | 8 | 0.4 | 1 | 0.548 | 0.493 | 0.219 | 0.219 | 0.197 | 0.088 |
| NOJY157M006#WJ | Y | 150 | 6.3 | 18.0 | 6 | 0.4 | 3 | 0.612 | 0.551 | 0.245 | 0.245 | 0.220 | 0.098 |
| NOJY227M006#WJ | Y | 220 | 6.3 | 26.4 | 10 | 0.4 | 3 | 0.612 | 0.551 | 0.245 | 0.245 | 0.220 | 0.098 |
| 10 Volt @ 85°C (7 Volt @ 105°C) | | | | | | | | | | | | | |
| NOJP225M010#WJ | P | 2.2 | 10 | 1.0 | 8 | 8.3 | 1 | 0.093 | 0.084 | 0.037 | 0.773 | 0.696 | 0.309 |
| NOJP335M010#WJ | P | 3.3 | 10 | 1.0 | 8 | 7 | 1 | 0.101 | 0.091 | 0.041 | 0.710 | 0.639 | 0.284 |
| NOJT475M010#WJ | T | 4.7 | 10 | 1.0 | 6 | 3.1 | 1 | 0.176 | 0.158 | 0.070 | 0.546 | 0.491 | 0.218 |
| NOJT685M010#WJ | T | 6.8 | 10 | 1.4 | 6 | 2.6 | 1 | 0.192 | 0.173 | 0.077 | 0.500 | 0.450 | 0.200 |
| NOJT106M010#WJ | T | 10 | 10 | 2.0 | 6 | 2.2 | 1 | 0.209 | 0.188 | 0.084 | 0.460 | 0.414 | 0.184 |

Moisture Sensitivity Level (MSL) is defined according to J-STD-020.

All technical data relates to an ambient temperature of +25°C. Capacitance and DF are measured at 120Hz, 0.5V RMS with a maximum DC bias of 2.2 volts.

DCL is measured at rated voltage after 5 minutes.

The EIA & CECC standards for capacitors allow an ESR movement to 1.25 times catalog limit post mounting.

For typical weight and composition see page 144.

NOTE: AVX reserves the right to supply a higher voltage rating or tighter tolerance part in the same case size, to the same reliability standards.

OxiCap® NLJ Series



Niobium Oxide Capacitors High CV Consumer Series



- High Volumetric efficiency
- Environmentally friendly
- 3xreflow 260°C compatible
- Consumer applications
- OxiCap® non-burn technology
- RoHS compliance
- Lead-free solution
- 6 case sizes available
- CV range: 22-150µF / 4-10V



Elektra Award
2005

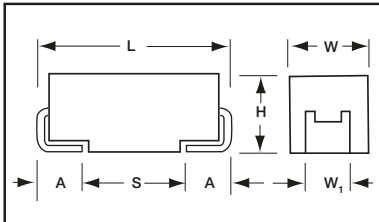

For part marking see page 151

CASE DIMENSIONS: millimeters (inches)

| Code | EIA Code | EIA Metric | L±0.20 (0.008) | W+0.20 (0.008) -0.10 (0.004) | H+0.20 (0.008) -0.10 (0.004) | W ₁ ±0.20 (0.008) | A+0.30 (0.012) -0.20 (0.008) | S Min. |
|------|----------|------------|----------------|------------------------------|------------------------------|------------------------------|------------------------------|--------------|
| A | 1206 | 3216-18 | 3.20 (0.126) | 1.60 (0.063) | 1.60 (0.063) | 1.20 (0.047) | 0.80 (0.031) | 1.10 (0.043) |
| B | 1210 | 3528-21 | 3.50 (0.138) | 2.80 (0.110) | 1.90 (0.075) | 2.20 (0.087) | 0.80 (0.031) | 1.40 (0.055) |
| C | 2312 | 6032-28 | 6.00 (0.236) | 3.20 (0.126) | 2.60 (0.102) | 2.20 (0.087) | 1.30 (0.051) | 2.90 (0.114) |
| D | 2917 | 7343-31 | 7.30 (0.287) | 4.30 (0.169) | 2.90 (0.114) | 2.40 (0.094) | 1.30 (0.051) | 4.40 (0.173) |
| G | 1206 | 3216-15 | 3.20 (0.126) | 1.60 (0.063) | 1.50 (0.059) max | 1.20 (0.047) | 0.80 (0.031) | 1.10 (0.043) |
| P | 0805 | 2012-15 | 2.05 (0.081) | 1.35 (0.053) | 1.50 (0.059) max | 1.00±0.10 (0.039±0.004) | 0.50 (0.020) | 0.85 (0.033) |
| S | 1206 | 3216-12 | 3.20 (0.126) | 1.60 (0.063) | 1.20 (0.047) max | 1.20 (0.047) | 0.80 (0.031) | 1.10 (0.043) |
| T | 1210 | 3528-12 | 3.50 (0.138) | 2.80 (0.110) | 1.20 (0.047) max | 2.20 (0.087) | 0.80 (0.031) | 1.40 (0.055) |
| W | 2312 | 6032-15 | 6.00 (0.236) | 3.20 (0.126) | 1.50 (0.059) max | 2.20 (0.087) | 1.30 (0.051) | 2.90 (0.114) |
| Y | 2917 | 7343-20 | 7.30 (0.287) | 4.30 (0.169) | 2.00 (0.079) max | 2.40 (0.094) | 1.30 (0.051) | 4.40 (0.173) |

W₁ dimension applies to the termination width for A dimensional area only.

HOW TO ORDER

| | | | | | | |
|-------------|-------------------------------------|--|----------------------------|--|---|------------------|
| NLJ | A | 476 | M | 006 | R | 1600 |
| Type | Case Size See table above | Capacitance Code 1st two digits represent significant figures, 3rd digit represents multiplier in pF | Tolerance M=±20% | Rated DC Voltage 004 = 4Vdc 006 = 6.3Vdc 010 = 10Vdc | Packaging R = Pure Tin 7" Reel S = Pure Tin 13" Reel | ESR in mΩ |

Under development

TECHNICAL SPECIFICATIONS

| | | | | | |
|------------------------------------|---|------|------|-----|--|
| Technical Data: | All technical data relate to an ambient temperature of +25°C | | | | |
| Capacitance Range: | 6.8 µF to 1000 µF | | | | |
| Capacitance Tolerance: | ±20% | | | | |
| Leakage Current DCL: | 0.1CV | | | | |
| Rated Voltage DC (V _R) | -55°C ≤ +40°C: | 4 | 6.3 | 10 | |
| Category Voltage (V _C) | at 85°C: | 2 | 3.15 | 5 | |
| Category Voltage (V _C) | at 105°C: | 1.32 | 2 | 3.3 | |
| Temperature Range: | -55°C to +105°C with category voltage | | | | |
| Reliability: | 0.2% per 1000 hours at 85°C, 0.5xV _R , 0.1Ω/V series impedance with 60% confidence level | | | | |

OxiCap® NLJ Series



Niobium Oxide Capacitors High CV Consumer Series

CAPACITANCE AND RATED VOLTAGE RANGE (LETTER DENOTES CASE SIZE)

| Capacitance | | Rated Voltage DC to 40°C / 0.5DC to 85°C / 0.33DC to 105°C | | |
|-------------|------|--|------------------|-----------------------------|
| µF | Code | 4V (G) | 6.3V (J) | 10V (A) |
| 6.8 | 685 | | | K(4000)*/P(5000)* |
| 10 | 106 | | K(4000)* | K(2200)*/P(6000)* |
| 15 | 156 | K(4000)*/P(4000)* | P(3500)* | L(2800)*/S(2000)* |
| 22 | 226 | P(4000) | L(2500)*/S(1800) | A(4000)/G(3000) L(2200)* |
| 33 | 336 | A(3000)*/S(1700)* | G(2200)/L(2500)* | A(1700)/T(1800)* |
| 47 | 476 | A(2600)*/G(2600)* L(1600)* | A(1600)/T(1600) | B(1000)/H(1000)* W(400)* |
| 68 | 686 | A(1500)*/T(1500)* | H(900)* | B(1400)* |
| 100 | 107 | H(900)* | B(1700)/W(600)* | C(1200)*/Y(1200)* |
| 150 | 157 | B(1500)/W(400)* | | |
| 220 | 227 | | | D(1000)* |
| 330 | 337 | | C(500)*/Y(500)* | |
| 470 | 477 | C(500)*/Y(500)* | | |
| 680 | 687 | | D(500)* | |
| 1000 | 108 | D(500)* | | |



LEAD-FREE

LEAD-FREE COMPATIBLE
COMPONENT



RoHS
COMPLIANT



NON-BURN
NON-SMOKE

Available Ratings, (ESR ratings in mOhms in brackets)

Engineering samples - please contact manufacturer

*Codes under development - subject to change

Note: Voltage ratings are minimum values. AVX reserves the right to supply higher ratings in the same case size, to the same reliability standards.

RATINGS & PART NUMBER REFERENCE

| AVX Part No. | Case Size | Capacitance (µF) | Rated Voltage (V) | Maximum Surge Current (A)* | DCL (µA) Max. | ESR Max. (mΩ) @100kHz | MSL | 100kHz Ripple Current (mA) | | | 100kHz Ripple Voltage (mV) | | |
|--|-----------|------------------|-------------------|----------------------------|---------------|-----------------------|-----|----------------------------|------|-------|----------------------------|------|-------|
| | | | | | | | | 25°C | 85°C | 105°C | 25°C | 85°C | 105°C |
| 4 Volt @ 85°C (1.32 Volt @ 105°C) | | | | | | | | | | | | | |
| NLJP226M004#4000 | P | 22 | 4 | 0.4 | 8.8 | 4000 | 3 | 134 | 121 | 54 | 537 | 483 | 215 |
| NLJB157M004#1500 | B | 150 | 4 | 1.0 | 60.0 | 1500 | 3 | 261 | 235 | 104 | 391 | 352 | 156 |
| NLJW157M004#0400 | W | 150 | 4 | 2.4 | 60.0 | 400 | 3 | 520 | 468 | 208 | 208 | 187 | 83 |
| NLJC477M004#0500 | C | 470 | 4 | 2.1 | 188.0 | 500 | 3 | 514 | 462 | 206 | 257 | 231 | 103 |
| NLJY477M004#0500 | Y | 470 | 4 | 2.1 | 188.0 | 500 | 3 | 548 | 493 | 219 | 274 | 246 | 110 |
| NLJD108M004#0500 | D | 1000 | 4 | 2.1 | 400.0 | 500 | 3 | 600 | 540 | 240 | 300 | 270 | 120 |
| 6.3 Volt @ 85°C (2 Volt @ 105°C) | | | | | | | | | | | | | |
| NLJS226M006#1800 | S | 22 | 6.3 | 1.4 | 13.2 | 1800 | 3 | 208 | 187 | 83 | 375 | 337 | 150 |
| NLJG336M006#2200 | G | 33 | 6.3 | 1.2 | 19.8 | 2200 | 3 | 195 | 176 | 78 | 430 | 387 | 172 |
| NLJA476M006#1600 | A | 47 | 6.3 | 1.5 | 28.2 | 1600 | 3 | 237 | 213 | 98 | 379 | 342 | 152 |
| NLJT476M006#1600 | T | 47 | 6.3 | 1.5 | 28.2 | 1600 | 3 | 245 | 220 | 98 | 392 | 353 | 157 |
| NLJB107M006#1700 | B | 100 | 6.3 | 1.5 | 60.0 | 1700 | 3 | 245 | 220 | 98 | 416 | 375 | 167 |
| NLJW107M006#0600 | W | 100 | 6.3 | 3.0 | 60.0 | 600 | 3 | 424 | 382 | 170 | 255 | 229 | 102 |
| NLJC337M006#0500 | C | 330 | 6.3 | 3.3 | 198.0 | 500 | 3 | 514 | 462 | 206 | 257 | 231 | 103 |
| NLJY337M006#0500 | Y | 330 | 6.3 | 3.3 | 198.0 | 500 | 3 | 548 | 493 | 219 | 274 | 246 | 110 |
| NLJD687M006#0500 | D | 680 | 6.3 | 3.3 | 408.0 | 500 | 3 | 600 | 540 | 240 | 300 | 270 | 120 |
| 10 Volt @ 85°C (3.3 Volt @ 105°C) | | | | | | | | | | | | | |
| NLJA226M010#4000 | A | 22 | 10 | 1.1 | 22.0 | 4000 | 3 | 150 | 135 | 60 | 600 | 540 | 240 |
| NLJG226M010#3000 | G | 22 | 10 | 1.4 | 22.0 | 3000 | 3 | 167 | 151 | 67 | 502 | 452 | 201 |
| NLJA336M010#1700 | A | 33 | 10 | 2.3 | 33.0 | 1700 | 3 | 230 | 207 | 92 | 391 | 352 | 156 |
| NLJB476M010#1000 | B | 47 | 10 | 3.4 | 47.0 | 1000 | 3 | 319 | 287 | 128 | 319 | 287 | 128 |
| NLJW476M010#0400 | W | 47 | 10 | 5.9 | 47.0 | 400 | 3 | 520 | 468 | 208 | 208 | 187 | 83 |
| NLJC107M010#1200 | C | 100 | 10 | 3.0 | 100.0 | 1200 | 3 | 332 | 298 | 133 | 398 | 358 | 159 |
| NLJY107M010#1200 | Y | 100 | 10 | 3.0 | 100.0 | 1200 | 3 | 354 | 318 | 141 | 424 | 382 | 170 |
| NLJD227M010#1000 | D | 220 | 10 | 3.4 | 220.0 | 1000 | 3 | 424 | 382 | 170 | 424 | 382 | 170 |

Moisture Sensitivity Level (MSL) is defined according to J-STD-020.

All technical data relates to an ambient temperature of +25°C. Capacitance and DF are measured at 120Hz, 0.5V RMS with a maximum DC bias of 2.2 volts. DCL is measured at rated voltage after 5 minutes.

ESR allowed to move up to 1.25 times catalogue limit post mounting
DCL allowed to move up to 2.00 times catalogue limit post mounting

For typical weight and composition see page 144.

NOTE: AVX reserves the right to supply a higher voltage rating or tighter tolerance part in the same case size, to the same reliability standards.

Voltage vs Temperature Rating

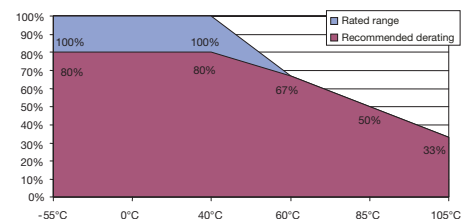

OxiCap® NOS Low ESR Series



Niobium Oxide Capacitor

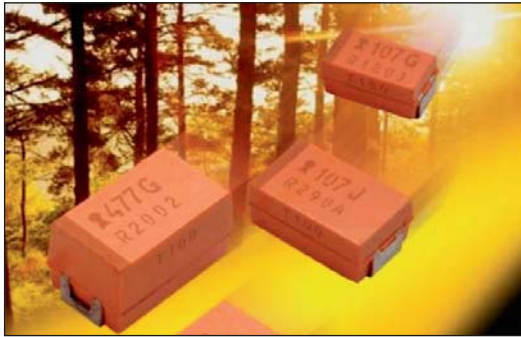

- Low ESR NbO capacitors
- Non-burn safe technology
- Reliability level: 0.2%/1000 hrs.
- CV range: 10-1000µF / 1.8-6.3V
- 9 case sizes available
- IBM global approval received in 2004
- Electra Award received in 2005



Electra Award
2005

CASE DIMENSIONS: millimeters (inches)

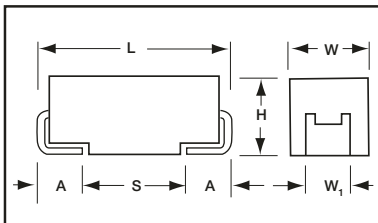

For part marking see page 151

| Code | EIA Code | EIA Metric | L±0.20 (0.008) | W+0.20 (0.008) -0.10 (0.004) | H+0.20 (0.008) -0.10 (0.004) | W, ±0.20 (0.008) | A+0.30 (0.012) -0.20 (0.008) | S Min. |
|------|----------|------------|----------------|---------------------------------|---------------------------------|------------------|---------------------------------|--------------|
| A | 1206 | 3216-18 | 3.20 (0.126) | 1.60 (0.063) | 1.60 (0.063) | 1.20 (0.047) | 0.80 (0.031) | 1.10 (0.043) |
| B | 1210 | 3528-21 | 3.50 (0.138) | 2.80 (0.110) | 1.90 (0.075) | 2.20 (0.087) | 0.80 (0.031) | 1.40 (0.055) |
| C | 2312 | 6032-28 | 6.00 (0.236) | 3.20 (0.126) | 2.60 (0.102) | 2.20 (0.087) | 1.30 (0.051) | 2.90 (0.114) |
| D | 2917 | 7343-31 | 7.30 (0.287) | 4.30 (0.169) | 2.90 (0.114) | 2.40 (0.094) | 1.30 (0.051) | 4.40 (0.173) |
| E | 2917 | 7343-43 | 7.30 (0.287) | 4.30 (0.169) | 4.10 (0.162) | 2.40 (0.094) | 1.30 (0.051) | 4.40 (0.173) |
| V | 2924 | 7361-38 | 7.30 (0.287) | 6.10 (0.240) | 3.55 (0.140) | 3.10 (0.120) | 1.30 (0.051) | 4.40 (0.173) |
| W | 2312 | 6032-15 | 6.00 (0.236) | 3.20 (0.126) | 1.50 (0.059) max. | 2.20 (0.087) | 1.30 (0.051) | 2.90 (0.114) |
| X | 2917 | 7343-15 | 7.30 (0.287) | 4.30 (0.169) | 1.50 (0.059) max. | 2.40 (0.094) | 1.30 (0.051) | 4.40 (0.173) |
| Y | 2917 | 7343-20 | 7.30 (0.287) | 4.30 (0.169) | 2.00 (0.079) max. | 2.40 (0.094) | 1.30 (0.051) | 4.40 (0.173) |

W₁ dimension applies to the termination width for A dimensional area only.

HOW TO ORDER

| | | | | | | | |
|-------------|-------------------------------------|--|----------------------------|---|---|------------------|---|
| NOS | D | 107 | M | 006 | R | 0100 | - |
| Type | Case Size See table above | Capacitance Code 1st two digits represent significant figures, 3rd digit represents multiplier in pF | Tolerance M=±20% | Rated DC Voltage 001 = 1.8Vdc 002 = 2.5Vdc 004 = 4Vdc 006 = 6.3Vdc | Packaging R = Pure Tin 7" Reel S = Pure Tin 13" Reel | ESR in mΩ | Additional characters may be added for special requirements V = Dry pack Option (selected codes only) with exception of D, E, X, Y, V cases |

TECHNICAL SPECIFICATIONS

| | | | | | |
|------------------------------------|---|-----|-----|-----|-----|
| Technical Data: | All technical data relate to an ambient temperature of +25°C is not stated | | | | |
| Capacitance Range: | 10 µF to 1000 µF | | | | |
| Capacitance Tolerance: | ±20% | | | | |
| Leakage Current DCL: | 0.02CV | | | | |
| Rated Voltage DC (V _R) | ≤ +85°C: | 1.8 | 2.5 | 4 | 6.3 |
| Category Voltage (V _C) | ≤ +125°C: | 0.9 | 1.3 | 2 | 3 |
| Surge Voltage (V _S) | ≤ +85°C: | 2.3 | 3.3 | 5.2 | 8 |
| Surge Voltage (V _S) | ≤ +125°C: | 1.2 | 1.7 | 2.6 | 4 |
| Temperature Range: | -55°C to +125°C | | | | |
| Reliability: | 0.2% per 1000 hours at 85°C, V _R , 0.1Ω/V series impedance, 60% confidence level Meets requirements of AEC-Q200 | | | | |

OxiCap® NOS Low ESR Series



Niobium Oxide Capacitor

CAPACITANCE AND RATED VOLTAGE RANGE (LETTER DENOTES CASE SIZE)

| Capacitance | | Rated Voltage DC (V _R) to 85°C / 0.66 DC to 105°C / 0.5 DC to 125°C | | | |
|-------------|------|---|------------------------|-------------------------------|-------------------------------|
| µF | Code | 1.8V (x) | 2.5V (e) | 4.0V (G) | 6.3V (J) |
| 4.7 | 475 | | | | |
| 6.8 | 685 | | | | |
| 10 | 106 | | | | A(800, 1000, 2000) |
| 15 | 156 | | | A(1500) | B(600) |
| 22 | 226 | | A(900) | B(600) | B(600) |
| 33 | 336 | | | B(600) | B(600) C(500) W(250) |
| 47 | 476 | | B(500) | B(500) C(300) W(150) | B(500) C(300) |
| 68 | 686 | | C(200) W(150) | C(200) | C(75,200) X(100) Y(100) |
| 100 | 107 | B(350) W(150) | C(150) | C(70,150) X(100) | C(150) D(80,100) Y(100) |
| 150 | 157 | | C(65,150) X(100) | C(90,150) Y(100) | D(50,70,100) Y(100) |
| 220 | 227 | C(125) X(100) | C(80,125) Y(100) | D(40,60,100) Y(100) | D(45,60,100) E(80,100) |
| 330 | 337 | Y(100) | D(35,50,100) Y(100) | D(35,55,100) E(100)/Y(150) | E(80,100) |
| 470 | 477 | Y(100) | D(35,55,100) E(100) | D(100) E(75,100) | E(75)/V(75) |
| 680 | 687 | | E(60) | V(75) | |
| 1000 | 108 | | V(50) | | |



LEAD-FREE

LEAD-FREE COMPATIBLE
COMPONENT



RoHS
COMPLIANT



NON-BURN
NON-SMOKE

Available Ratings, (ESR ratings in mOhms in brackets)

Engineering samples - please contact manufacturer

*Codes under development - subject to change

Note: Voltage ratings are minimum values. AVX reserves the right to supply higher ratings in the same case size, to the same reliability standards.

OxiCap® NOS Low ESR Series



Niobium Oxide Capacitor

RATINGS & PART NUMBER REFERENCE

| AVX Part No. | Case Size | Capacitance (µF) | Rated Voltage (V) | DCL (µA) Max. | DF % Max. | ESR Max. (mΩ) @100kHz | MSL | 100kHz RMS Current (A) | | | 100kHz RMS Voltage (V) | | |
|---|-----------|------------------|-------------------|---------------|-----------|-----------------------|-----|------------------------|-------|-------|------------------------|-------|-------|
| | | | | | | | | 25°C | 85°C | 125°C | 25°C | 85°C | 125°C |
| 1.8 Volt @ 85°C (1.2 Volt @ 105°C, 0.9 Volt @ 125°C) | | | | | | | | | | | | | |
| NOSB107M001#0350 | B | 100 | 1.8 | 3.6 | 6 | 350 | 1 | 0.540 | 0.486 | 0.216 | 0.189 | 0.170 | 0.076 |
| NOSW107M001#0150 | W | 100 | 1.8 | 3.6 | 6 | 150 | 1 | 0.849 | 0.764 | 0.339 | 0.127 | 0.115 | 0.051 |
| NOSC227M001#0125 | C | 220 | 1.8 | 8.0 | 8 | 125 | 1 | 1.028 | 0.925 | 0.411 | 0.128 | 0.116 | 0.051 |
| NOSX227M001#0100 | X | 220 | 1.8 | 8.0 | 8 | 100 | 3 | 1.095 | 0.986 | 0.438 | 0.110 | 0.099 | 0.044 |
| NOSY337M001#0100 | Y | 330 | 1.8 | 11.9 | 8 | 100 | 3 | 1.225 | 1.102 | 0.490 | 0.122 | 0.110 | 0.049 |
| NOSY477M001#0100 | Y | 470 | 1.8 | 17.0 | 8 | 100 | 3 | 1.225 | 1.102 | 0.490 | 0.122 | 0.110 | 0.049 |
| 2.5 Volt @ 85°C (1.7 Volt @ 105°C, 1.3 Volt @ 125°C) | | | | | | | | | | | | | |
| NOSA226M002#0900 | A | 22 | 2.5 | 1.1 | 6 | 900 | 1 | 0.316 | 0.285 | 0.126 | 0.285 | 0.256 | 0.114 |
| NOSB476M002#0500 | B | 47 | 2.5 | 2.4 | 6 | 500 | 1 | 0.452 | 0.406 | 0.181 | 0.226 | 0.203 | 0.090 |
| NOSC686M002#0200 | C | 68 | 2.5 | 3.4 | 6 | 200 | 1 | 0.812 | 0.731 | 0.325 | 0.162 | 0.146 | 0.065 |
| NOSW686M002#0150 | W | 68 | 2.5 | 3.4 | 6 | 150 | 1 | 0.849 | 0.764 | 0.339 | 0.127 | 0.115 | 0.051 |
| NOSC107M002#0150 | C | 100 | 2.5 | 5.0 | 6 | 150 | 1 | 0.938 | 0.844 | 0.375 | 0.141 | 0.127 | 0.056 |
| NOSC157M002#0065 | C | 150 | 2.5 | 7.5 | 6 | 65 | 1 | 1.425 | 1.283 | 0.570 | 0.093 | 0.083 | 0.037 |
| NOSC157M002#0150 | C | 150 | 2.5 | 7.5 | 6 | 150 | 1 | 0.938 | 0.844 | 0.375 | 0.141 | 0.127 | 0.056 |
| NOSC157M002#0100 | X | 150 | 2.5 | 7.5 | 6 | 100 | 3 | 1.095 | 0.986 | 0.438 | 0.110 | 0.099 | 0.044 |
| NOSC227M002#0080 | C | 220 | 2.5 | 11.0 | 8 | 80 | 1 | 1.285 | 1.156 | 0.514 | 0.103 | 0.092 | 0.041 |
| NOSC227M002#0125 | C | 220 | 2.5 | 11.0 | 8 | 125 | 1 | 1.028 | 0.925 | 0.411 | 0.128 | 0.116 | 0.051 |
| NOSY227M002#0100 | Y | 220 | 2.5 | 11.0 | 8 | 100 | 3 | 1.225 | 1.102 | 0.490 | 0.122 | 0.110 | 0.049 |
| NOSD337M002#0035 | D | 330 | 2.5 | 16.5 | 10 | 35 | 3 | 2.268 | 2.041 | 0.907 | 0.079 | 0.071 | 0.032 |
| NOSD337M002#0050 | D | 330 | 2.5 | 16.5 | 10 | 50 | 3 | 1.897 | 1.708 | 0.759 | 0.095 | 0.085 | 0.038 |
| NOSD337M002#0100 | D | 330 | 2.5 | 16.5 | 10 | 100 | 3 | 1.342 | 1.207 | 0.537 | 0.134 | 0.121 | 0.054 |
| NOSY337M002#0100 | Y | 330 | 2.5 | 16.5 | 10 | 100 | 3 | 1.225 | 1.102 | 0.490 | 0.122 | 0.110 | 0.049 |
| NOSD477M002#0035 | D | 470 | 2.5 | 23.5 | 12 | 35 | 3 | 2.268 | 2.041 | 0.907 | 0.079 | 0.071 | 0.032 |
| NOSD447M002#0055 | D | 470 | 2.5 | 23.5 | 12 | 55 | 3 | 1.809 | 1.628 | 0.724 | 0.099 | 0.090 | 0.040 |
| NOSD447M002#0100 | D | 470 | 2.5 | 23.5 | 12 | 100 | 3 | 1.342 | 1.207 | 0.537 | 0.134 | 0.121 | 0.054 |
| NOSE477M002#0100 | E | 470 | 2.5 | 23.5 | 10 | 100 | 3 | 1.407 | 1.266 | 0.563 | 0.141 | 0.127 | 0.056 |
| NOSE687M002#0060 | E | 680 | 2.5 | 34.0 | 14 | 60 | 3 | 1.817 | 1.635 | 0.727 | 0.109 | 0.098 | 0.044 |
| NOSV108M002#0050 | V | 1000 | 2.5 | 50.0 | 16 | 50 | 3 | 2.449 | 2.205 | 0.980 | 0.122 | 0.110 | 0.049 |
| 4 Volt @ 85°C (2.6 Volt @ 105°C, 2 Volt @ 125°C) | | | | | | | | | | | | | |
| NOSA156M004#1500 | A | 15 | 4 | 1.2 | 6 | 1500 | 1 | 0.245 | 0.220 | 0.098 | 0.367 | 0.331 | 0.147 |
| NOSB226M004#0600 | B | 22 | 4 | 1.8 | 6 | 600 | 1 | 0.412 | 0.371 | 0.165 | 0.247 | 0.223 | 0.099 |
| NOSB336M004#0600 | B | 33 | 4 | 2.6 | 6 | 600 | 1 | 0.412 | 0.371 | 0.165 | 0.247 | 0.223 | 0.099 |
| NOSB476M004#0500 | B | 47 | 4 | 3.8 | 6 | 500 | 1 | 0.452 | 0.406 | 0.181 | 0.226 | 0.203 | 0.090 |
| NOSC476M004#0300 | C | 47 | 4 | 3.8 | 6 | 300 | 1 | 0.663 | 0.597 | 0.265 | 0.199 | 0.179 | 0.080 |
| NOSW476M004#0150 | W | 47 | 4 | 3.8 | 6 | 150 | 1 | 0.849 | 0.764 | 0.339 | 0.127 | 0.115 | 0.051 |
| NOSC686M004#0200 | C | 68 | 4 | 5.4 | 6 | 200 | 1 | 0.812 | 0.731 | 0.325 | 0.162 | 0.146 | 0.065 |
| NOSC107M004#0070 | C | 100 | 4 | 8.0 | 6 | 70 | 1 | 1.373 | 1.236 | 0.549 | 0.096 | 0.087 | 0.038 |
| NOSC107M004#0150 | C | 100 | 4 | 8.0 | 6 | 150 | 1 | 0.938 | 0.844 | 0.375 | 0.141 | 0.127 | 0.056 |
| NOSX107M004#0100 | X | 100 | 4 | 8.0 | 6 | 100 | 3 | 1.095 | 0.986 | 0.438 | 0.110 | 0.099 | 0.044 |
| NOSC157M004#0090 | C | 150 | 4 | 12.0 | 6 | 90 | 1 | 1.211 | 1.090 | 0.484 | 0.109 | 0.098 | 0.044 |
| NOSC157M004#0150 | C | 150 | 4 | 12.0 | 6 | 150 | 1 | 0.938 | 0.844 | 0.375 | 0.141 | 0.127 | 0.056 |
| NOSY157M004#0100 | Y | 150 | 4 | 12.0 | 6 | 100 | 3 | 1.225 | 1.102 | 0.490 | 0.122 | 0.110 | 0.049 |
| NOSD227M004#0040 | D | 220 | 4 | 17.6 | 8 | 40 | 3 | 2.121 | 1.909 | 0.849 | 0.085 | 0.076 | 0.034 |
| NOSD227M004#0060 | D | 220 | 4 | 17.6 | 8 | 60 | 3 | 1.732 | 1.559 | 0.693 | 0.104 | 0.094 | 0.042 |
| NOSD227M004#0100 | D | 220 | 4 | 17.6 | 8 | 100 | 3 | 1.342 | 1.207 | 0.537 | 0.134 | 0.121 | 0.054 |
| NOSY227M004#0100 | Y | 220 | 4 | 17.6 | 10 | 100 | 3 | 1.225 | 1.102 | 0.490 | 0.122 | 0.110 | 0.049 |
| NOSD337M004#0035 | D | 330 | 4 | 26.4 | 8 | 35 | 3 | 2.268 | 2.041 | 0.907 | 0.079 | 0.071 | 0.032 |
| NOSD337M004#0055 | D | 330 | 4 | 26.4 | 8 | 55 | 3 | 1.809 | 1.628 | 0.724 | 0.099 | 0.090 | 0.040 |
| NOSD337M004#0100 | D | 330 | 4 | 26.4 | 8 | 100 | 3 | 1.342 | 1.207 | 0.537 | 0.134 | 0.121 | 0.054 |
| NOSE337M004#0100 | E | 330 | 4 | 26.4 | 8 | 100 | 3 | 1.407 | 1.266 | 0.563 | 0.141 | 0.127 | 0.056 |
| NOSY337M004#0150 | Y | 330 | 4 | 26.4 | 12 | 150 | 3 | 1.000 | 0.900 | 0.400 | 0.150 | 0.135 | 0.060 |
| NOSD477M004#0100 | D | 470 | 4 | 37.6 | 12 | 100 | 3 | 1.342 | 1.207 | 0.537 | 0.134 | 0.121 | 0.054 |
| NOSE477M004#0075 | E | 470 | 4 | 37.6 | 12 | 75 | 3 | 1.625 | 1.462 | 0.650 | 0.122 | 0.110 | 0.049 |
| NOSE477M004#0100 | E | 470 | 4 | 37.6 | 12 | 100 | 3 | 1.407 | 1.266 | 0.563 | 0.141 | 0.127 | 0.056 |
| NOSV687M004#0075 | V | 680 | 4 | 54.4 | 14 | 75 | 3 | 2.000 | 1.800 | 0.800 | 0.150 | 0.135 | 0.060 |

Moisture Sensitivity Level (MSL) is defined according to J-STD-020.

All technical data relates to an ambient temperature of +25°C. Capacitance and DF are measured at 120Hz, 0.5V RMS with a maximum DC bias of 2.2 volts. DCL is measured at rated voltage after 5 minutes.

ESR allowed to move, up to 1.25 times catalog limit post mounting.

For typical weight and composition see page 144.

NOTE: AVX reserves the right to supply a higher voltage rating or tighter tolerance part in the same case size, to the same reliability standards.



OxiCap® NOS Low ESR Series



Niobium Oxide Capacitor

RATINGS & PART NUMBER REFERENCE

| AVX Part No. | Case Size | Capacitance (µF) | Rated Voltage (V) | DCL (µA) Max. | DF % Max. | ESR Max. (mΩ) @100kHz | MSL | 100kHz RMS Current (A) | | | 100kHz RMS Voltage (V) | | |
|---|-----------|------------------|-------------------|---------------|-----------|-----------------------|-----|------------------------|-------|-------|------------------------|-------|-------|
| | | | | | | | | 25°C | 85°C | 125°C | 25°C | 85°C | 125°C |
| 6.3 Volt @ 85°C (4 Volt @ 105°C, 3 Volt @ 125°C) | | | | | | | | | | | | | |
| NOSA106M006#0800 | A | 10 | 6.3 | 1.2 | 6 | 800 | 1 | 0.335 | 0.302 | 0.134 | 0.268 | 0.241 | 0.107 |
| NOSA106M006#1000 | A | 10 | 6.3 | 1.2 | 6 | 1000 | 1 | 0.300 | 0.270 | 0.120 | 0.300 | 0.270 | 0.120 |
| NOSA106M006#2000 | A | 10 | 6.3 | 1.2 | 6 | 2000 | 1 | 0.212 | 0.191 | 0.085 | 0.424 | 0.382 | 0.170 |
| NOSB156M006#0600 | B | 15 | 6.3 | 1.8 | 6 | 600 | 1 | 0.412 | 0.371 | 0.165 | 0.247 | 0.223 | 0.099 |
| NOSB226M006#0600 | B | 22 | 6.3 | 2.6 | 6 | 600 | 1 | 0.412 | 0.371 | 0.165 | 0.247 | 0.223 | 0.099 |
| NOSB336M006#0600 | B | 33 | 6.3 | 4.0 | 6 | 600 | 1 | 0.412 | 0.371 | 0.165 | 0.247 | 0.223 | 0.099 |
| NOSC336M006#0500 | C | 33 | 6.3 | 4.0 | 6 | 500 | 1 | 0.514 | 0.462 | 0.206 | 0.257 | 0.231 | 0.103 |
| NOSV336M006#0250 | W | 33 | 6.3 | 4.0 | 6 | 250 | 1 | 0.657 | 0.592 | 0.263 | 0.164 | 0.148 | 0.066 |
| NOSB476M006#0500 | B | 47 | 6.3 | 5.6 | 6 | 500 | 1 | 0.452 | 0.406 | 0.181 | 0.226 | 0.203 | 0.090 |
| NOSC476M006#0300 | C | 47 | 6.3 | 5.7 | 6 | 300 | 1 | 0.663 | 0.597 | 0.265 | 0.199 | 0.179 | 0.080 |
| NOSC686M006#0075 | C | 68 | 6.3 | 8.2 | 6 | 75 | 1 | 1.327 | 1.194 | 0.531 | 0.099 | 0.090 | 0.040 |
| NOSC686M006#0200 | C | 68 | 6.3 | 8.2 | 6 | 200 | 1 | 0.812 | 0.731 | 0.325 | 0.162 | 0.146 | 0.065 |
| NOSX686M006#0100 | X | 68 | 6.3 | 8.2 | 6 | 100 | 3 | 1.095 | 0.986 | 0.438 | 0.110 | 0.099 | 0.044 |
| NOSY686M006#0100 | Y | 68 | 6.3 | 8.2 | 6 | 100 | 3 | 1.225 | 1.102 | 0.490 | 0.122 | 0.110 | 0.049 |
| NOSC107M006#0150 | C | 100 | 6.3 | 12.0 | 8 | 150 | 1 | 0.938 | 0.844 | 0.375 | 0.141 | 0.127 | 0.056 |
| NOSD107M006#0080 | D | 100 | 6.3 | 12.0 | 6 | 80 | 3 | 1.500 | 1.350 | 0.600 | 0.120 | 0.108 | 0.048 |
| NOSD107M006#0100 | D | 100 | 6.3 | 12.0 | 6 | 100 | 3 | 1.342 | 1.207 | 0.537 | 0.134 | 0.121 | 0.054 |
| NOSY107M006#0100 | Y | 100 | 6.3 | 12.0 | 6 | 100 | 3 | 1.225 | 1.102 | 0.490 | 0.122 | 0.110 | 0.049 |
| NOSD157M006#0050 | D | 150 | 6.3 | 18.0 | 6 | 50 | 3 | 1.897 | 1.708 | 0.759 | 0.095 | 0.085 | 0.038 |
| NOSD157M006#0070 | D | 150 | 6.3 | 18.0 | 6 | 70 | 3 | 1.604 | 1.443 | 0.641 | 0.112 | 0.101 | 0.045 |
| NOSD157M006#0100 | D | 150 | 6.3 | 18.0 | 6 | 100 | 3 | 1.342 | 1.207 | 0.537 | 0.134 | 0.121 | 0.054 |
| NOSY157M006#0100 | Y | 150 | 6.3 | 18.0 | 6 | 100 | 3 | 1.225 | 1.102 | 0.490 | 0.122 | 0.110 | 0.049 |
| NOSD227M006#0045 | D | 220 | 6.3 | 26.4 | 8 | 45 | 3 | 2.000 | 1.800 | 0.800 | 0.090 | 0.081 | 0.036 |
| NOSD227M006#0060 | D | 220 | 6.3 | 26.4 | 8 | 60 | 3 | 1.732 | 1.559 | 0.693 | 0.104 | 0.094 | 0.042 |
| NOSD227M006#0100 | D | 220 | 6.3 | 26.4 | 8 | 100 | 3 | 1.342 | 1.207 | 0.537 | 0.134 | 0.121 | 0.054 |
| NOSE227M006#0080 | E | 220 | 6.3 | 26.4 | 12 | 80 | 3 | 1.573 | 1.416 | 0.629 | 0.126 | 0.113 | 0.050 |
| NOSE227M006#0100 | E | 220 | 6.3 | 26.4 | 12 | 100 | 3 | 1.407 | 1.266 | 0.563 | 0.141 | 0.127 | 0.056 |
| NOSE337M006#0080 | E | 330 | 6.3 | 39.6 | 12 | 80 | 3 | 1.573 | 1.416 | 0.629 | 0.126 | 0.113 | 0.050 |
| NOSE337M006#0100 | E | 330 | 6.3 | 39.6 | 12 | 100 | 3 | 1.407 | 1.266 | 0.563 | 0.141 | 0.127 | 0.056 |
| NOSE477M006#0075 | E | 470 | 6.3 | 56.4 | 16 | 75 | 3 | 1.625 | 1.462 | 0.650 | 0.122 | 0.110 | 0.049 |
| NOSV477M006#0075 | V | 470 | 6.3 | 56.4 | 14 | 75 | 3 | 2.000 | 1.800 | 0.800 | 0.150 | 0.135 | 0.060 |

Moisture Sensitivity Level (MSL) is defined according to J-STD-020.

All technical data relates to an ambient temperature of +25°C. Capacitance and DF are measured at 120Hz, 0.5V RMS with a maximum DC bias of 2.2 volts. DCL is measured at rated voltage after 5 minutes.

The EIA & CECC standards for low ESR Solid Tantalum Capacitors allow an ESR movement to 1.25 times catalogue limit post mounting.

For typical weight and composition see page 144.

NOTE: AVX reserves the right to supply a higher voltage rating or tighter tolerance part in the same case size, to the same reliability standards.

OxiCap® NOM Low ESR Multianodes



Niobium Oxide Capacitor

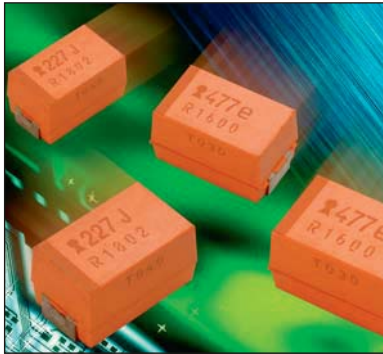

- Multi-anode construction
- Super low ESR
- Non-burn safe technology
- CV range: 220-680µF / 1.8-6.3V
- IBM global approval received in 2004
- Electra award received in 2005



Electra Award
2005

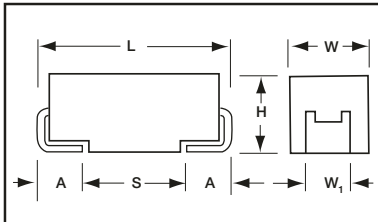

For part marking see page 151

CASE DIMENSIONS: millimeters (inches)

| Code | EIA Code | EIA Metric | L±0.20 (0.008) | W+0.20 (0.008) -0.10 (0.004) | H+0.20 (0.008) -0.10 (0.004) | W, ±0.20 (0.008) | A+0.30 (0.012) -0.20 (0.008) | S Min. |
|------|----------|------------|----------------|------------------------------|------------------------------|------------------|------------------------------|--------------|
| E | 2917 | 7343-43 | 7.30 (0.287) | 4.30 (0.169) | 4.10 (0.162) | 2.40 (0.094) | 1.30 (0.051) | 4.40 (0.173) |

W₁ dimension applies to the termination width for A dimensional area only.

HOW TO ORDER

NOM

Type

E

Case Size
See table above

227

Capacitance Code
1st two digits represent significant figures, 3rd digit represents multiplier in pF

M

Tolerance
M=±20%

006

Rated DC Voltage
001 = 1.8Vdc
002 = 2.5Vdc
004 = 4Vdc
006 = 6.3Vdc

R

Packaging
R = Pure Tin 7" Reel
S = Pure Tin 13" Reel

0040

ESR in mΩ

TECHNICAL SPECIFICATIONS

| | | | | | |
|------------------------------------|---|-----|-----|-----|-----|
| Technical Data: | All technical data relate to an ambient temperature of +25°C is not stated | | | | |
| Capacitance Range: | 220 µF to 680 µF | | | | |
| Capacitance Tolerance: | ±20% | | | | |
| Leakage Current DCL: | 0.02CV | | | | |
| Rated Voltage DC (V _R) | ≤ +85°C: | 1.8 | 2.5 | 4 | 6.3 |
| Category Voltage (V _C) | ≤ +125°C: | 0.9 | 1.3 | 2 | 3 |
| Surge Voltage (V _S) | ≤ +85°C: | 2.3 | 3.3 | 5.2 | 8 |
| Surge Voltage (V _S) | ≤ +125°C: | 1.2 | 1.7 | 2.6 | 4 |
| Temperature Range: | -55°C to +125°C | | | | |
| Reliability: | 0.2% per 1000 hours at 85°C, V _R , 0.1Ω/V series impedance, 60% confidence level Meets requirements of AEC-Q200 | | | | |



OxiCap® NOM Low ESR Multianodes



Niobium Oxide Capacitor

CAPACITANCE AND RATED VOLTAGE RANGE (LETTER DENOTES CASE SIZE)

| Capacitance | | Rated Voltage DC (V _R) to 85°C / 0.66 DC to 105°C / 0.5 DC to 125°C | | | |
|-------------|------|---|----------|----------|----------|
| µF | Code | 1.8V (x) | 2.5V (e) | 4.0V (G) | 6.3V (J) |
| 220 | 227 | | | | E(40) |
| 330 | 337 | | | E(35) | E(23,35) |
| 470 | 477 | | E(30) | E(23,30) | |
| 680 | 687 | E(23) | E(23) | | |

Available Ratings, (ESR ratings in mOhms in brackets)

Engineering samples - please contact manufacturer

*Codes under development - subject to change

Note: Voltage ratings are minimum values. AVX reserves the right to supply higher ratings in the same case size, to the same reliability standards.



LEAD-FREE

LEAD-FREE COMPATIBLE
COMPONENT



RoHS
COMPLIANT



NON-BURN
NON-SMOKE

RATINGS & PART NUMBER REFERENCE

| AVX Part No. | Case Size | Capacitance (µF) | Rated Voltage (V) | DCL (µA) Max. | DF % Max. | ESR Max. (mΩ) @100kHz | MSL | 100kHz RMS Current (A) | | | 100kHz RMS Voltage (V) | | |
|--|-----------|------------------|-------------------|---------------|-----------|-----------------------|-----|------------------------|-------|-------|------------------------|-------|-------|
| | | | | | | | | 25°C | 85°C | 125°C | 25°C | 85°C | 125°C |
| 1.8 Volt @ 85°C (1.2 Volt @ 105°C / 0.9 Volt @ 125°C) | | | | | | | | | | | | | |
| NOME687M001#0023 | E | 680 | 1.8 | 24.5 | 6 | 23 | 3 | 3.753 | 3.378 | 1.501 | 0.086 | 0.078 | 0.035 |
| 2.5 Volt @ 85°C (1.7 Volt @ 105°C / 1.3 Volt @ 125°C) | | | | | | | | | | | | | |
| NOME477M002#0030 | E | 470 | 2.5 | 23.5 | 10 | 30 | 3 | 3.286 | 2.958 | 1.315 | 0.099 | 0.089 | 0.039 |
| NOME687M002#0023 | E | 680 | 2.5 | 34 | 6 | 23 | 3 | 3.753 | 3.378 | 1.501 | 0.086 | 0.078 | 0.035 |
| 4 Volt @ 85°C (2.6 Volt @ 105°C / 2 Volt @ 125°C) | | | | | | | | | | | | | |
| NOME337M004#0035 | E | 330 | 4 | 26.4 | 8 | 35 | 3 | 3.043 | 2.738 | 1.217 | 0.106 | 0.096 | 0.043 |
| NOME477M004#0023 | E | 470 | 4 | 37.6 | 6 | 23 | 3 | 3.753 | 3.378 | 1.501 | 0.086 | 0.078 | 0.035 |
| NOME477M004#0030 | E | 470 | 4 | 37.6 | 6 | 30 | 3 | 3.286 | 2.958 | 1.315 | 0.099 | 0.089 | 0.039 |
| 6.3 Volt @ 85°C (4 Volt @ 105°C / 3 Volt @ 125°C) | | | | | | | | | | | | | |
| NOME227M006#0040 | E | 220 | 6.3 | 26.4 | 12 | 40 | 3 | 2.846 | 2.561 | 1.138 | 0.114 | 0.102 | 0.046 |
| NOME337M006#0023 | E | 330 | 6.3 | 39.6 | 6 | 23 | 3 | 3.753 | 3.378 | 1.501 | 0.086 | 0.078 | 0.035 |
| NOME337M006#0035 | E | 330 | 6.3 | 39.6 | 6 | 35 | 3 | 3.043 | 2.738 | 1.217 | 0.106 | 0.096 | 0.043 |

Moisture Sensitivity Level (MSL) is defined according to J-STD-020.

All technical data relates to an ambient temperature of +25°C. Capacitance and DF are measured at 120Hz, 0.5V RMS with a maximum DC bias of 2.2 volts.

DCL is measured at rated voltage after 5 minutes.

ESR allowed to move up to 125 times catalog limit post mounting.

For typical weight and composition see page 144.

NOTE: AVX reserves the right to supply a higher voltage rating or tighter tolerance part in the same case size, to the same reliability standards.

Section 3: Introduction



Foreword

AVX offers a broad line of solid Tantalum capacitors in a wide range of sizes, styles, and ratings to meet any design needs. This catalog combines into one source AVX's leaded tantalum capacitor information from its worldwide tantalum operations.

The TAP/TEP is rated for use from -55°C to +85°C at rated voltage and up to +125°C with voltage derating. There are three preferred wire forms to choose from which are available on tape and reel, and in bulk for hand insertion.

AVX has a complete tantalum applications service available for use by all our customers. With the capability to prototype and mass produce solid tantalum capacitors in special configurations, almost any design need can be fulfilled.

And if the customer requirements are outside our standard testing, AVX will work with you to define and implement a test or screening plan.

AVX is determined to become the world leader in tantalum capacitor technology and has made, and is continuing to make, significant investments in equipment and research to reach that end. We believe that the investment has paid off with the devices shown on the following pages.

Dipped Radial Capacitors

SOLID TANTALUM RESIN DIPPED SERIES TAP/TEP

The TAP/TEP resin dipped series of miniature tantalum capacitors is available for individual needs in both commercial and professional applications. From computers to automotive to industrial, AVX has a dipped radial for almost any application.

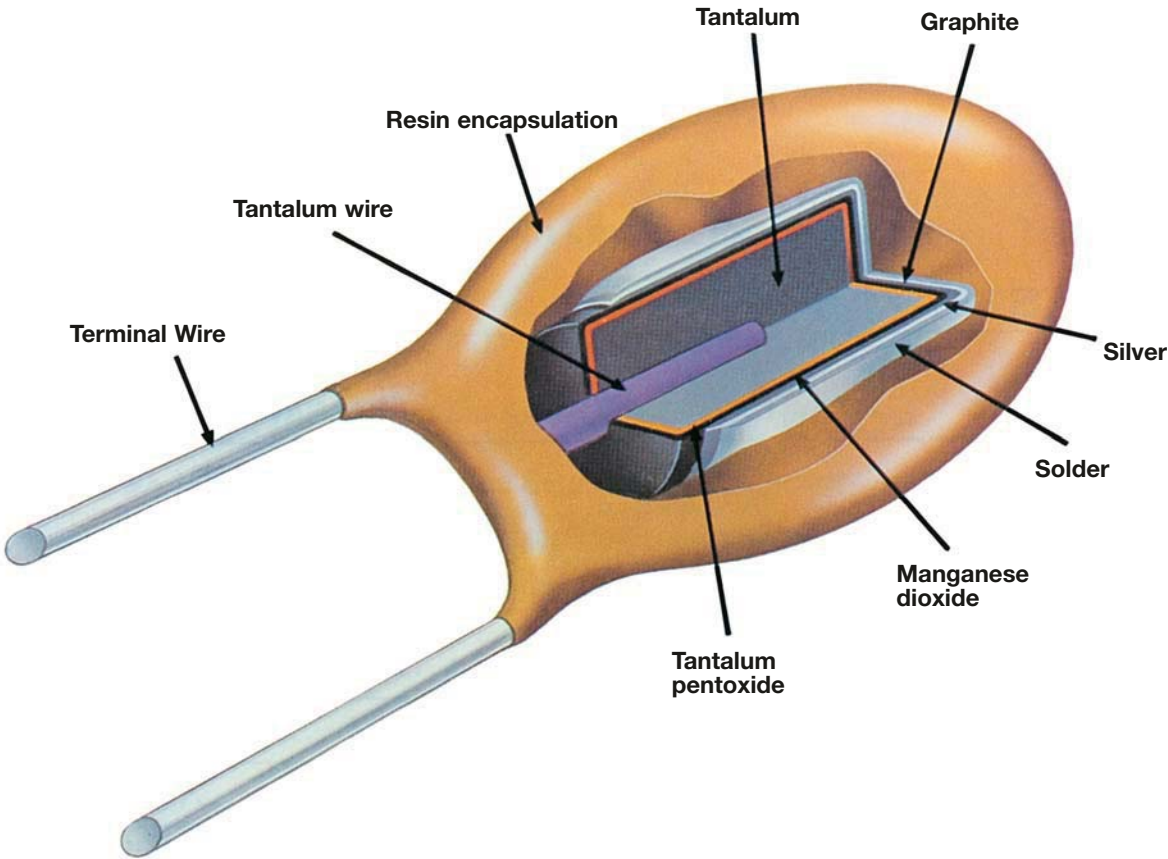

Dipped Radial Capacitors



Wire Form Outline

SOLID TANTALUM RESIN DIPPED TAP/TEP

Preferred Wire Forms

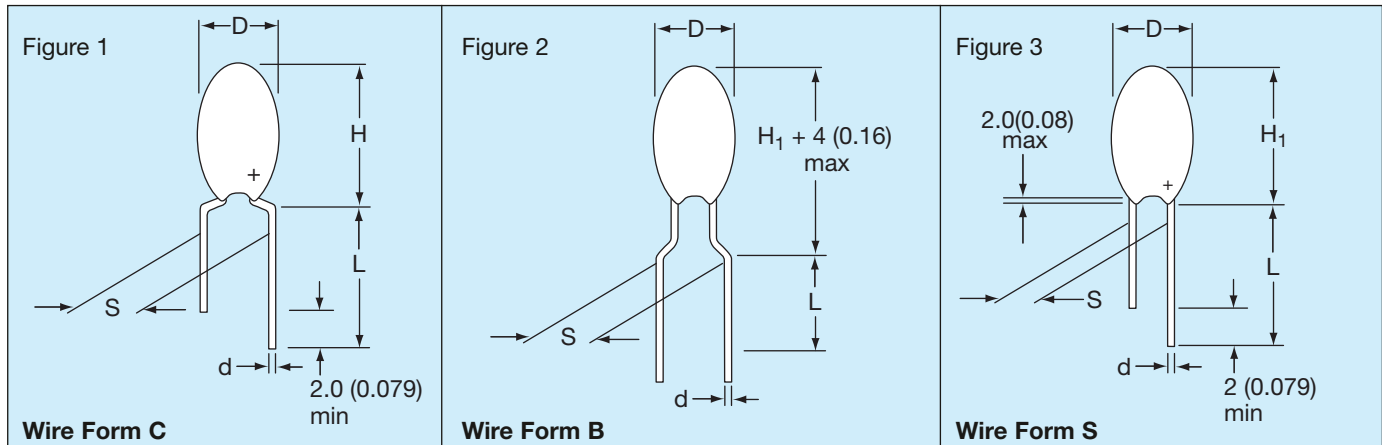

Non-Preferred Wire Forms (Not recommended for new designs)

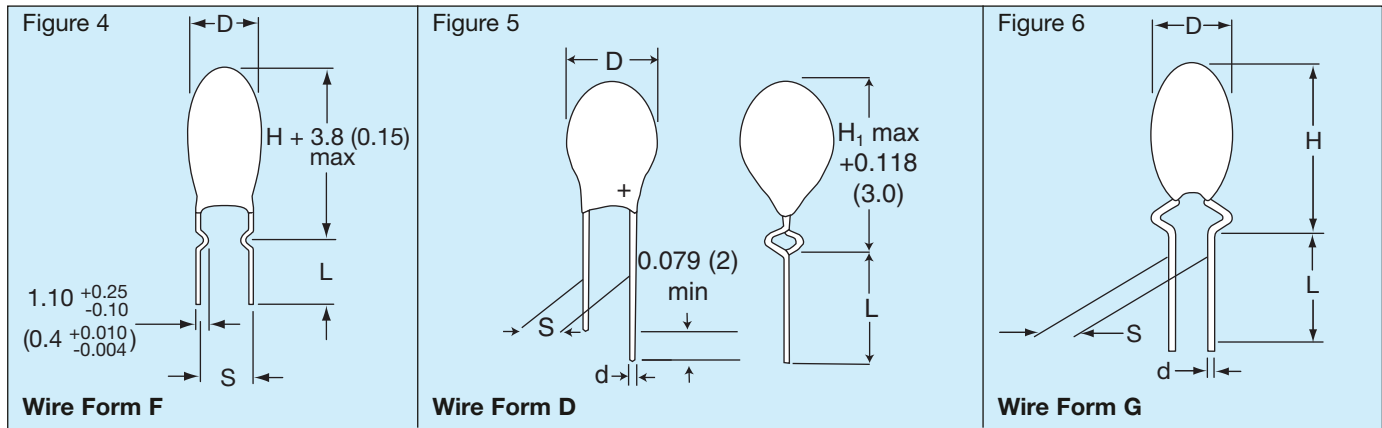

DIMENSIONS

millimeters (inches)

| Wire Form | Figure | Case Size | L (see note 1) | S | d | Packaging Suffixes Available* |
|-----------|--------|-----------|----------------|---|---|-------------------------------|
|-----------|--------|-----------|----------------|---|---|-------------------------------|

Preferred Wire Forms

| | | | | | | |
|---|----------|--------|----------------------------|----------------------------|----------------------------|--|
| C | Figure 1 | A - R* | 16.0±4.00 (0.630±0.160) | 5.00±1.00 (0.200±0.040) | 0.50±0.05 (0.020±0.002) | CCS Bulk CRW Tape/Reel CRS Tape/Ammo |
| B | Figure 2 | A - J* | 16.0±4.00 (0.630±0.160) | 5.00±1.00 (0.200±0.040) | 0.50±0.05 (0.020±0.002) | BRW Tape/Reel BRS Tape/Ammo |
| S | Figure 3 | A - J* | 16.0±4.00 (0.630±0.160) | 2.50±0.50 (0.100±0.020) | 0.50±0.05 (0.020±0.002) | SCS Bulk SRW Tape/Reel SRS Tape/Ammo |

Non-Preferred Wire Forms (Not recommended for new designs)

| | | | | | | |
|---|---------------------|--------|----------------------------|----------------------------|----------------------------|--|
| F | Figure 4 | A - R | 3.90±0.75 (0.155±0.030) | 5.00±0.50 (0.200±0.020) | 0.50±0.05 (0.020±0.002) | FCS Bulk |
| D | Figure 5 | A - H* | 16.0±4.00 (0.630±0.160) | 2.50±0.75 (0.100±0.020) | 0.50±0.05 (0.020±0.002) | DCS Bulk DTW Tape/Reel DTS Tape/Ammo |
| G | Figure 6 | A - J | 16.0±4.00 (0.630±0.160) | 3.18±0.50 (0.125±0.020) | 0.50±0.05 (0.020±0.002) | GSB Bulk |
| H | Similar to Figure 1 | A - R | 16.0±4.00 (0.630±0.160) | 6.35±1.00 (0.250±0.040) | 0.50±0.05 (0.020±0.002) | HSB Bulk |

Notes: (1) Lead lengths can be supplied to tolerances other than those above and should be specified in the ordering information.

(2) For D, H, and H₁ dimensions, refer to individual product on following pages.

* For case size availability in tape and reel, please refer to pages 123-124.



Dipped Radial Capacitors



TAP Series

SOLID TANTALUM RESIN DIPPED CAPACITORS

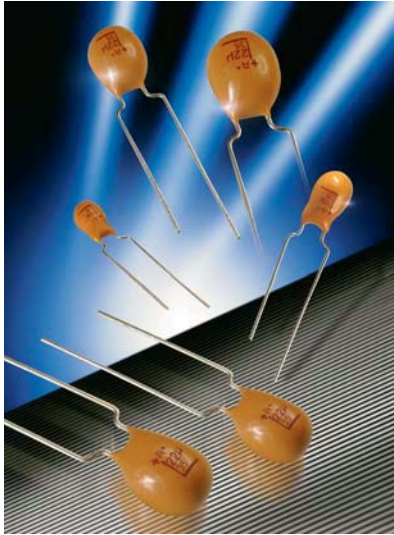

TAP is a professional grade device manufactured with a flame retardant coating and featuring low leakage current and impedance, very small physical sizes and exceptional temperature stability. It is designed and conditioned to operate to +125°C (see page 153 for voltage derating above 85°C) and is available loose or taped and reeled for auto insertion. The 15 case sizes with wide capacitance and working voltage ranges means the TAP can accommodate almost any application.



MAXIMUM CASE DIMENSIONS: millimeters (inches)

| Wire Case | C, F, G, H H | B, S, D *H ₁ | D |
|-----------|-----------------|----------------------------|--------------|
| A | 8.50 (0.330) | 7.00 (0.280) | 4.50 (0.180) |
| B | 9.00 (0.350) | 7.50 (0.300) | 4.50 (0.180) |
| C | 10.0 (0.390) | 8.50 (0.330) | 5.00 (0.200) |
| D | 10.5 (0.410) | 9.00 (0.350) | 5.00 (0.200) |
| E | 10.5 (0.410) | 9.00 (0.350) | 5.50 (0.220) |
| F | 11.5 (0.450) | 10.0 (0.390) | 6.00 (0.240) |
| G | 11.5 (0.450) | 10.0 (0.390) | 6.50 (0.260) |
| H | 12.0 (0.470) | 10.5 (0.410) | 7.00 (0.280) |
| J | 13.0 (0.510) | 11.5 (0.450) | 8.00 (0.310) |
| K | 14.0 (0.550) | 12.5 (0.490) | 8.50 (0.330) |
| L | 14.0 (0.550) | 12.5 (0.490) | 9.00 (0.350) |
| M | 14.5 (0.570) | 13.0 (0.510) | 9.00 (0.350) |
| N | 16.0 (0.630) | | 9.00 (0.350) |
| P | 17.0 (0.670) | | 10.0 (0.390) |
| R | 18.5 (0.730) | | 10.0 (0.390) |

HOW TO ORDER

TAP

Type

475

Capacitance Code
pF code: 1st two digits represent significant figures, 3rd digit represents multiplier (number of zeros to follow)

M

Capacitance Tolerance
K = ±10%
M = ±20%
(For J = ±5% tolerance, please consult factory)

035

Rated DC Voltage

SCS

Suffix indicating wire form and packaging
(see page 116)



Dipped Radial Capacitors



TAP Series

TECHNICAL SPECIFICATIONS

| | | | | | | | | |
|-------------------------------|---|-----|-----|----|----|----|----|----|
| Technical Data: | All technical data relate to an ambient temperature of +25°C | | | | | | | |
| Capacitance Range: | 0.10 μ F to 330 μ F | | | | | | | |
| Capacitance Tolerance: | \pm 20%; \pm 10% (\pm 5% consult your AVX representative for details) | | | | | | | |
| Rated Voltage DC (V_R) | $\leq +85^\circ\text{C}$: | 6.3 | 10 | 16 | 20 | 25 | 35 | 50 |
| Category Voltage (V_C) | $\leq +125^\circ\text{C}$: | 4 | 6.3 | 10 | 13 | 16 | 23 | 33 |
| Surge Voltage (V_S) | $\leq +85^\circ\text{C}$: | 8 | 13 | 20 | 26 | 33 | 46 | 65 |
| Surge Voltage (V_S) | $\leq +125^\circ\text{C}$: | 5 | 9 | 12 | 16 | 21 | 28 | 40 |
| Temperature Range: | -55°C to +125°C | | | | | | | |
| Environmental Classification: | 55/125/56 (IEC 68-2) | | | | | | | |
| Dissipation Factor: | \leq 0.04 for C_R 0.1-1.5 μ F | | | | | | | |
| | \leq 0.06 for C_R 2.2-6.8 μ F | | | | | | | |
| | \leq 0.08 for C_R 10-68 μ F | | | | | | | |
| | \leq 0.10 for C_R 100-330 μ F | | | | | | | |
| Reliability: | 1% per 1000 hrs. at 85°C with 0.1 Ω /V series impedance, 60% confidence level. | | | | | | | |
| Qualification: | CECC 30201 - 032 | | | | | | | |

| Capacitance Range (letter denotes case size) | | | | | | | | |
|--|------|----------------------------|-----|-----|-----|-----|-----|-----|
| Capacitance | | Rated voltage DC (V_R) | | | | | | |
| μ F | Code | 6.3V | 10V | 16V | 20V | 25V | 35V | 50V |
| 0.10 | 104 | | | | | | A | A |
| 0.15 | 154 | | | | | | A | A |
| 0.22 | 224 | | | | | | A | A |
| 0.33 | 334 | | | | | | A | A |
| 0.47 | 474 | | | | | | A | A |
| 0.68 | 684 | | | | | | A | B |
| 1.0 | 105 | | | | A | A | A | C |
| 1.5 | 155 | | | A | A | A | A | D |
| 2.2 | 225 | | A | A | A | A | B | E |
| 3.3 | 335 | A | A | A | B | B | C | F |
| 4.7 | 475 | A | A | B | C | C | E | G |
| 6.8 | 685 | A | B | C | D | D | F | H |
| 10 | 106 | B | C | D | E | E | F | J |
| 15 | 156 | C | D | E | F | F | H | K |
| 22 | 226 | D | E | F | H | H | K | L |
| 33 | 336 | E | F | F | J | J | M | |
| 47 | 476 | F | G | J | K | K | N | |
| 68 | 686 | G | H | L | N | N | | |
| 100 | 107 | H | K | N | N | | | |
| 150 | 157 | K | N | N | | | | |
| 220 | 227 | M | P | R | | | | |
| 330 | 337 | P | R | | | | | |

Values outside this standard range may be available on request.
 AVX reserves the right to supply capacitors to a higher voltage rating, in the same case size, than that ordered.

MARKING

Polarity, capacitance, rated DC voltage, and an "A" (AVX logo) are laser marked on the capacitor body which is made of flame retardant gold epoxy resin with a limiting oxygen index in excess of 30 (ASTM-D-2863).

- Polarity
- Tolerance code:
- Capacitance \pm 20% = Standard (no marking)
- Voltage \pm 10% = "K" on reverse side of unit
- AVX logo \pm 5% = "J" on reverse side of unit

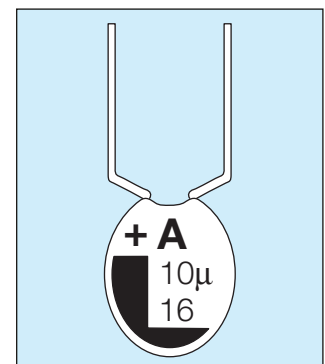

Dipped Radial Capacitors



TAP Series

RATINGS AND PART NUMBER REFERENCE

| AVX Part No. | Case Size | Capacitance μ F | DCL (μ A) Max. | DF % Max. | ESR Max. (Ω) @ 100 kHz |
|--|-----------|---------------------|---------------------|-----------|---------------------------------|
| 6.3 volt @ 85°C (4 volt @ 125°C) | | | | | |
| TAP 335(+006 | A | 3.3 | 0.5 | 6 | 13.0 |
| TAP 475(+006 | A | 4.7 | 0.5 | 6 | 10.0 |
| TAP 685(+006 | A | 6.8 | 0.5 | 6 | 8.0 |
| TAP 106(+006 | B | 10 | 0.5 | 8 | 6.0 |
| TAP 156(+006 | C | 15 | 0.8 | 8 | 5.0 |
| TAP 226(+006 | D | 22 | 1.1 | 8 | 3.7 |
| TAP 336(+006 | E | 33 | 1.7 | 8 | 3.0 |
| TAP 476(+006 | F | 47 | 2.4 | 8 | 2.0 |
| TAP 686(+006 | G | 68 | 3.4 | 8 | 1.8 |
| TAP 107(+006 | H | 100 | 5.0 | 10 | 1.6 |
| TAP 157(+006 | K | 150 | 7.6 | 10 | 0.9 |
| TAP 227(+006 | M | 220 | 11.0 | 10 | 0.9 |
| TAP 337(+006 | P | 330 | 16.6 | 10 | 0.7 |
| 10 volt @ 85°C (6.3 volt @ 125°C) | | | | | |
| TAP 225(+010 | A | 2.2 | 0.5 | 6 | 13.0 |
| TAP 335(+010 | A | 3.3 | 0.5 | 6 | 10.0 |
| TAP 475(+010 | A | 4.7 | 0.5 | 6 | 8.0 |
| TAP 685(+010 | B | 6.8 | 0.5 | 6 | 6.0 |
| TAP 106(+010 | C | 10 | 0.8 | 8 | 5.0 |
| TAP 156(+010 | D | 15 | 1.2 | 8 | 3.7 |
| TAP 226(+010 | E | 22 | 1.7 | 8 | 2.7 |
| TAP 336(+010 | F | 33 | 2.6 | 8 | 2.1 |
| TAP 476(+010 | G | 47 | 3.7 | 8 | 1.7 |
| TAP 686(+010 | H | 68 | 5.4 | 8 | 1.3 |
| TAP 107(+010 | K | 100 | 8.0 | 10 | 1.0 |
| TAP 157(+010 | N | 150 | 12.0 | 10 | 0.8 |
| TAP 227(+010 | P | 220 | 17.6 | 10 | 0.6 |
| TAP 337(+010 | R | 330 | 20.0 | 10 | 0.5 |
| 16 volt @ 85°C (10 volt @ 125°C) | | | | | |
| TAP 155(+016 | A | 1.5 | 0.5 | 4 | 10.0 |
| TAP 225(+016 | A | 2.2 | 0.5 | 6 | 8.0 |
| TAP 335(+016 | A | 3.3 | 0.5 | 6 | 6.0 |
| TAP 475(+016 | B | 4.7 | 0.6 | 6 | 5.0 |
| TAP 685(+016 | C | 6.8 | 0.8 | 6 | 4.0 |
| TAP 106(+016 | D | 10 | 1.2 | 8 | 3.2 |
| TAP 156(+016 | E | 15 | 1.9 | 8 | 2.5 |
| TAP 226(+016 | F | 22 | 2.8 | 8 | 2.0 |
| TAP 336(+016 | F | 33 | 4.2 | 8 | 1.6 |
| TAP 476(+016 | J | 47 | 6.0 | 8 | 1.3 |
| TAP 686(+016 | L | 68 | 8.7 | 8 | 1.0 |
| TAP 107(+016 | N | 100 | 12.8 | 10 | 0.8 |
| TAP 157(+016 | N | 150 | 19.2 | 10 | 0.6 |
| TAP 227(+016 | R | 220 | 20.0 | 10 | 0.5 |
| 20 volt @ 85°C (13 volt @ 125°C) | | | | | |
| TAP 105(+020 | A | 1.0 | 0.5 | 4 | 10.0 |
| TAP 155(+020 | A | 1.5 | 0.5 | 4 | 9.0 |
| TAP 225(+020 | A | 2.2 | 0.5 | 6 | 7.0 |
| TAP 335(+020 | B | 3.3 | 0.5 | 6 | 5.5 |
| TAP 475(+020 | C | 4.7 | 0.7 | 6 | 4.5 |
| TAP 685(+020 | D | 6.8 | 1.0 | 6 | 3.6 |
| TAP 106(+020 | E | 10 | 1.6 | 8 | 2.9 |
| TAP 156(+020 | F | 15 | 2.4 | 8 | 2.3 |
| TAP 226(+020 | H | 22 | 3.5 | 8 | 1.8 |
| TAP 336(+020 | J | 33 | 5.2 | 8 | 1.4 |
| TAP 476(+020 | K | 47 | 7.5 | 8 | 1.2 |
| TAP 686(+020 | N | 68 | 10.8 | 8 | 0.9 |
| TAP 107(+020 | N | 100 | 16.0 | 10 | 0.6 |

| AVX Part No. | Case Size | Capacitance μ F | DCL (μ A) Max. | DF % Max. | ESR Max. (Ω) @ 100 kHz |
|---|-----------|---------------------|---------------------|-----------|---------------------------------|
| 25 volt @ 85°C (16 volt @ 125°C) | | | | | |
| TAP 105(+025 | A | 1.0 | 0.5 | 4 | 10.0 |
| TAP 155(+025 | A | 1.5 | 0.5 | 4 | 8.0 |
| TAP 225(+025 | A | 2.2 | 0.5 | 6 | 6.0 |
| TAP 335(+025 | B | 3.3 | 0.6 | 6 | 5.0 |
| TAP 475(+025 | C | 4.7 | 0.9 | 6 | 4.0 |
| TAP 685(+025 | D | 6.8 | 1.3 | 6 | 3.1 |
| TAP 106(+025 | E | 10 | 2.0 | 8 | 2.5 |
| TAP 156(+025 | F | 15 | 3.0 | 8 | 2.0 |
| TAP 226(+025 | H | 22 | 4.4 | 8 | 1.5 |
| TAP 336(+025 | J | 33 | 6.6 | 8 | 1.2 |
| TAP 476(+025 | M | 47 | 9.4 | 8 | 1.0 |
| TAP 686(+025 | N | 68 | 13.6 | 8 | 0.8 |
| 35 volt @ 85°C (23 volt @ 125°C) | | | | | |
| TAP 104(+035 | A | 0.1 | 0.5 | 4 | 26.0 |
| TAP 154(+035 | A | 0.15 | 0.5 | 4 | 21.0 |
| TAP 224(+035 | A | 0.22 | 0.5 | 4 | 17.0 |
| TAP 334(+035 | A | 0.33 | 0.5 | 4 | 15.0 |
| TAP 474(+035 | A | 0.47 | 0.5 | 4 | 13.0 |
| TAP 684(+035 | A | 0.68 | 0.5 | 4 | 10.0 |
| TAP 105(+035 | A | 1.0 | 0.5 | 4 | 8.0 |
| TAP 155(+035 | A | 1.5 | 0.5 | 4 | 6.0 |
| TAP 225(+035 | B | 2.2 | 0.6 | 6 | 5.0 |
| TAP 335(+035 | C | 3.3 | 0.9 | 6 | 4.0 |
| TAP 475(+035 | E | 4.7 | 1.3 | 6 | 3.0 |
| TAP 685(+035 | F | 6.8 | 1.9 | 6 | 2.5 |
| TAP 106(+035 | F | 10 | 2.8 | 8 | 2.0 |
| TAP 156(+035 | H | 15 | 4.2 | 8 | 1.6 |
| TAP 226(+035 | K | 22 | 6.1 | 8 | 1.3 |
| TAP 336(+035 | M | 33 | 9.2 | 8 | 1.0 |
| TAP 476(+035 | N | 47 | 10.0 | 8 | 0.8 |
| 50 volt @ 85°C (33 volt @ 125°C) | | | | | |
| TAP 104(+050 | A | 0.1 | 0.5 | 4 | 26.0 |
| TAP 154(+050 | A | 0.15 | 0.5 | 4 | 21.0 |
| TAP 224(+050 | A | 0.22 | 0.5 | 4 | 17.0 |
| TAP 334(+050 | A | 0.33 | 0.5 | 4 | 15.0 |
| TAP 474(+050 | A | 0.47 | 0.5 | 4 | 13.0 |
| TAP 684(+050 | B | 0.68 | 0.5 | 4 | 10.0 |
| TAP 105(+050 | C | 1.0 | 0.5 | 4 | 8.0 |
| TAP 155(+050 | D | 1.5 | 0.6 | 4 | 6.0 |
| TAP 225(+050 | E | 2.2 | 0.8 | 6 | 3.5 |
| TAP 335(+050 | F | 3.3 | 1.3 | 6 | 3.0 |
| TAP 475(+050 | G | 4.7 | 1.8 | 6 | 2.5 |
| TAP 685(+050 | H | 6.8 | 2.7 | 6 | 2.0 |
| TAP 106(+050 | J | 10 | 4.0 | 8 | 1.6 |
| TAP 156(+050 | K | 15 | 6.0 | 8 | 1.2 |
| TAP 226(+050 | L | 22 | 8.8 | 8 | 1.0 |

(*) Insert capacitance tolerance code; M for $\pm 20\%$, K for $\pm 10\%$ and J for $\pm 5\%$

NOTE: Voltage ratings are minimum values. AVX reserves the right to supply higher voltage ratings in the same case size.

Dipped Radial Capacitors



TEP Series Tin-Lead (Sn/Pb) Finish Product



TEP is a Tin-Lead finish version of the conformally coated tantalum radial leaded capacitor (TAP). It is a professional grade device manufactured with a flame retardant coating and featuring low leakage current and impedance, very small physical sizes and exceptional temperature stability, available in bulk and T&R packaging for auto insertion. The wide range of Capacitance, working voltages and case sizes enables TEP to accommodate to almost any application.

Not RoHS Compliant

CASE DIMENSIONS: millimeters (inches)

| Wire Case | C, F, G, H H | B, S, D *H ₁ | D |
|-----------|-----------------|----------------------------|--------------|
| A | 8.50 (0.335) | 7.00 (0.276) | 4.50 (0.177) |
| B | 9.00 (0.354) | 7.50 (0.295) | 4.50 (0.177) |
| C | 10.0 (0.394) | 8.50 (0.335) | 5.00 (0.197) |
| D | 10.5 (0.413) | 9.00 (0.354) | 5.00 (0.197) |
| E | 10.5 (0.413) | 9.00 (0.354) | 5.50 (0.217) |
| F | 11.5 (0.453) | 10.0 (0.394) | 6.00 (0.236) |
| G | 11.5 (0.453) | 10.0 (0.394) | 6.50 (0.256) |
| H | 12.0 (0.472) | 10.5 (0.413) | 7.00 (0.276) |
| J | 13.0 (0.512) | 11.5 (0.453) | 8.00 (0.315) |
| K | 14.0 (0.551) | | 8.50 (0.335) |
| L | 14.0 (0.551) | | 9.00 (0.354) |
| M | 14.5 (0.571) | | 9.00 (0.354) |
| N | 16.0 (0.630) | | 9.00 (0.354) |
| P | 17.0 (0.669) | | 10.0 (0.394) |
| R | 18.5 (0.728) | | 10.0 (0.394) |

HOW TO ORDER

TEP

Type

106

Capacitance Code
pF code: 1st two digits represent significant figures, 3rd digit represents multiplier (number of zeros to follow)

M

Capacitance Tolerance
K = ±10%
M = ±20%
(For J = ±5% tolerance, please consult factory)

016

Rated DC Voltage

SCS

Suffix indicating wire form and packaging
(see page 116)

Dipped Radial Capacitors



TEP Series

TECHNICAL SPECIFICATIONS

| | | | | | | | | |
|----------------------------|--|-----|-----|----|----|----|----|----|
| Technical Data: | All technical data relate to an ambient temperature of +25°C | | | | | | | |
| Capacitance Range: | 0.10 μ F to 330 μ F | | | | | | | |
| Capacitance Tolerance: | \pm 10%; \pm 20% (\pm 5% consult your AVX representative for details) | | | | | | | |
| Rated Voltage DC (V_R) | $\leq +85^\circ\text{C}$: | 6.3 | 10 | 16 | 20 | 25 | 35 | 50 |
| Category Voltage (V_C) | $\leq +125^\circ\text{C}$: | 4 | 6.3 | 10 | 13 | 16 | 23 | 33 |
| Surge Voltage (V_S) | $\leq +85^\circ\text{C}$: | 8 | 13 | 20 | 26 | 33 | 46 | 65 |
| Surge Voltage (V_S) | $\leq +125^\circ\text{C}$: | 5 | 9 | 12 | 16 | 21 | 28 | 40 |
| Temperature Range: | -55°C to +125°C | | | | | | | |
| Dissipation Factor: | \leq 0.04 for C_R 0.1-1.5 μ F | | | | | | | |
| | \leq 0.06 for C_R 2.2-6.8 μ F | | | | | | | |
| | \leq 0.08 for C_R 10-68 μ F | | | | | | | |
| | \leq 0.10 for C_R 100-330 μ F | | | | | | | |
| Reliability: | 1% per 1000 hrs. at 85°C, V_R with 0.1 Ω /V series impedance, 60% confidence level. | | | | | | | |

| Capacitance Range (letter denotes case size) | | | | | | | | |
|--|------|----------------------------|-----|-----|-----|-----|-----|-----|
| Capacitance | | Rated voltage DC (V_R) | | | | | | |
| μ F | Code | 6.3V | 10V | 16V | 20V | 25V | 35V | 50V |
| 0.10 | 104 | | | | | | A | A |
| 0.15 | 154 | | | | | | A | A |
| 0.22 | 224 | | | | | | A | A |
| 0.33 | 334 | | | | | | A | A |
| 0.47 | 474 | | | | | | A | A |
| 0.68 | 684 | | | | | | A | B |
| 1.0 | 105 | | | | A | A | A | C |
| 1.5 | 155 | | | A | A | A | A | D |
| 2.2 | 225 | | A | A | A | A | B | E |
| 3.3 | 335 | A | A | A | B | B | C | F |
| 4.7 | 475 | A | A | B | C | C | E | G |
| 6.8 | 685 | A | B | C | D | D | F | H |
| 10 | 106 | B | C | D | E | E | F | J |
| 15 | 156 | C | D | E | F | F | H | K |
| 22 | 226 | D | E | F | H | H | K | L |
| 33 | 336 | E | F | F | J | J | M | |
| 47 | 476 | F | G | J | K | M | N | |
| 68 | 686 | G | H | L | N | N | | |
| 100 | 107 | H | K | N | N | | | |
| 150 | 157 | K | N | N | | | | |
| 220 | 227 | M | P | R | | | | |
| 330 | 337 | P | R | | | | | |

Values outside this standard range may be available on request.
 AVX reserves the right to supply capacitors to a higher voltage rating, in the same case size, than that ordered.

MARKING

Polarity, capacitance, rated DC voltage, and an "A" (AVX logo) are laser marked on the capacitor body which is made of flame retardant gold epoxy resin with a limiting oxygen index in excess of 30 (ASTM-D-2863).

- Polarity
- Capacitance
- Voltage
- AVX logo
- Tolerance code:
 - \pm 20% = Standard (no marking)
 - \pm 10% = "K" on reverse side of unit
 - \pm 5% = "J" on reverse side of unit

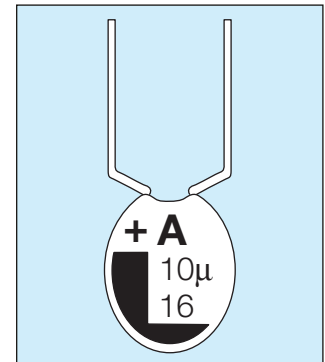

Dipped Radial Capacitors



TEP Series

RATINGS & PART NUMBER REFERENCE

| AVX Part No. | Case Size | Cap (µF) | DCL (µA) Max. | DF % Max. | ESR Max. (Ω) @100kHz |
|--------------|-----------|----------|---------------|-----------|----------------------|
| TEP335(*)006 | A | 3.3 | 0.5 | 6 | 13 |
| TEP475(*)006 | A | 4.7 | 0.5 | 6 | 10 |
| TEP685(*)006 | A | 6.8 | 0.5 | 6 | 8 |
| TEP106(*)006 | B | 10 | 0.5 | 8 | 6 |
| TEP156(*)006 | C | 15 | 0.8 | 8 | 5 |
| TEP226(*)006 | D | 22 | 1.1 | 8 | 3.7 |
| TEP336(*)006 | E | 33 | 1.7 | 8 | 3 |
| TEP476(*)006 | F | 47 | 2.4 | 8 | 2 |
| TEP686(*)006 | G | 68 | 3.4 | 8 | 1.8 |
| TEP107(*)006 | H | 100 | 5 | 10 | 1.6 |
| TEP157(*)006 | K | 150 | 7.6 | 10 | 0.9 |
| TEP227(*)006 | M | 220 | 11 | 10 | 0.9 |
| TEP337(*)006 | P | 330 | 16.6 | 10 | 0.7 |
| TEP335(*)006 | A | 3.3 | 0.5 | 6 | 13 |
| TEP225(*)010 | A | 2.2 | 0.5 | 6 | 13 |
| TEP335(*)010 | A | 3.3 | 0.5 | 6 | 10 |
| TEP475(*)010 | A | 4.7 | 0.5 | 6 | 8 |
| TEP685(*)010 | B | 6.8 | 0.5 | 6 | 6 |
| TEP106(*)010 | C | 10 | 0.8 | 8 | 5 |
| TEP156(*)010 | D | 15 | 1.2 | 8 | 3.7 |
| TEP226(*)010 | E | 22 | 1.7 | 8 | 2.7 |
| TEP336(*)010 | F | 33 | 2.6 | 8 | 2.1 |
| TEP476(*)010 | G | 47 | 3.7 | 8 | 1.7 |
| TEP686(*)010 | H | 68 | 5.4 | 8 | 1.3 |
| TEP107(*)010 | K | 100 | 8 | 10 | 1 |
| TEP157(*)010 | N | 150 | 12 | 10 | 0.8 |
| TEP227(*)010 | P | 220 | 17.6 | 10 | 0.6 |
| TEP337(*)010 | R | 330 | 20 | 10 | 0.5 |
| TEP155(*)016 | A | 1.5 | 0.5 | 4 | 10 |
| TEP225(*)016 | A | 2.2 | 0.5 | 6 | 8 |
| TEP335(*)016 | A | 3.3 | 0.5 | 6 | 6 |
| TEP475(*)016 | B | 4.7 | 0.6 | 6 | 5 |
| TEP685(*)016 | C | 6.8 | 0.8 | 6 | 4 |
| TEP106(*)016 | D | 10 | 1.2 | 8 | 3.2 |
| TEP156(*)016 | E | 15 | 1.9 | 8 | 2.5 |
| TEP226(*)016 | F | 22 | 2.8 | 8 | 2 |
| TEP336(*)016 | F | 33 | 4.2 | 8 | 1.6 |
| TEP476(*)016 | J | 47 | 6 | 8 | 1.3 |
| TEP686(*)016 | L | 68 | 8.7 | 8 | 1 |
| TEP107(*)016 | N | 100 | 12.8 | 10 | 0.8 |
| TEP157(*)016 | N | 150 | 19.2 | 10 | 0.6 |
| TEP227(*)016 | R | 220 | 20 | 10 | 0.5 |
| TEP105(*)020 | A | 1 | 0.5 | 4 | 10 |
| TEP155(*)020 | A | 1.5 | 0.5 | 4 | 9 |
| TEP225(*)020 | A | 2.2 | 0.5 | 6 | 7 |
| TEP335(*)020 | B | 3.3 | 0.5 | 6 | 5.5 |
| TEP475(*)020 | C | 4.7 | 0.7 | 6 | 4.5 |
| TEP685(*)020 | D | 6.8 | 1 | 6 | 3.6 |
| TEP106(*)020 | E | 10 | 1.6 | 8 | 2.9 |
| TEP156(*)020 | F | 15 | 2.4 | 8 | 2.3 |

| AVX Part No. | Case Size | Cap (µF) | DCL (µA) Max. | DF % Max. | ESR Max. (Ω) @100kHz |
|--------------|-----------|----------|---------------|-----------|----------------------|
| TEP226(*)020 | H | 22 | 3.5 | 8 | 1.8 |
| TEP336(*)020 | J | 33 | 5.2 | 8 | 1.4 |
| TEP476(*)020 | K | 47 | 7.5 | 8 | 1.2 |
| TEP686(*)020 | N | 68 | 10.8 | 8 | 0.9 |
| TEP107(*)020 | N | 100 | 16 | 10 | 0.6 |
| TEP105(*)025 | A | 1 | 0.5 | 4 | 10 |
| TEP155(*)025 | A | 1.5 | 0.5 | 4 | 8 |
| TEP225(*)025 | A | 2.2 | 0.5 | 6 | 6 |
| TEP335(*)025 | B | 3.3 | 0.6 | 6 | 5 |
| TEP475(*)025 | C | 4.7 | 0.9 | 6 | 4 |
| TEP685(*)025 | D | 6.8 | 1.3 | 6 | 3.1 |
| TEP106(*)025 | E | 10 | 2 | 8 | 2.5 |
| TEP156(*)025 | F | 15 | 3 | 8 | 2 |
| TEP226(*)025 | H | 22 | 4.4 | 8 | 1.5 |
| TEP336(*)025 | J | 33 | 6.6 | 8 | 1.2 |
| TEP476(*)025 | M | 47 | 9.4 | 8 | 1 |
| TEP686(*)025 | N | 68 | 13.6 | 8 | 0.8 |
| TEP104(*)035 | A | 0.1 | 0.5 | 4 | 26 |
| TEP154(*)035 | A | 0.15 | 0.5 | 4 | 21 |
| TEP224(*)035 | A | 0.22 | 0.5 | 4 | 17 |
| TEP334(*)035 | A | 0.33 | 0.5 | 4 | 15 |
| TEP474(*)035 | A | 0.47 | 0.5 | 4 | 13 |
| TEP684(*)035 | A | 0.68 | 0.5 | 4 | 10 |
| TEP105(*)035 | A | 1 | 0.5 | 4 | 8 |
| TEP155(*)035 | A | 1.5 | 0.5 | 4 | 6 |
| TEP225(*)035 | B | 2.2 | 0.6 | 6 | 5 |
| TEP335(*)035 | C | 3.3 | 0.9 | 6 | 4 |
| TEP475(*)035 | E | 4.7 | 1.3 | 6 | 3 |
| TEP685(*)035 | F | 6.8 | 1.9 | 6 | 2.5 |
| TEP106(*)035 | F | 10 | 2.8 | 8 | 2 |
| TEP156(*)035 | H | 15 | 4.2 | 8 | 1.6 |
| TEP226(*)035 | K | 22 | 6.1 | 8 | 1.3 |
| TEP336(*)035 | M | 33 | 9.2 | 8 | 1 |
| TEP476(*)035 | N | 47 | 10 | 8 | 0.8 |
| TEP104(*)050 | A | 0.1 | 0.5 | 4 | 26 |
| TEP154(*)050 | A | 0.15 | 0.5 | 4 | 21 |
| TEP224(*)050 | A | 0.22 | 0.5 | 4 | 17 |
| TEP334(*)050 | A | 0.33 | 0.5 | 4 | 15 |
| TEP474(*)050 | A | 0.47 | 0.5 | 4 | 13 |
| TEP684(*)050 | B | 0.68 | 0.5 | 4 | 10 |
| TEP105(*)050 | C | 1 | 0.5 | 4 | 8 |
| TEP155(*)050 | D | 1.5 | 0.6 | 4 | 6 |
| TEP225(*)050 | E | 2.2 | 0.8 | 6 | 3.5 |
| TEP335(*)050 | F | 3.3 | 1.3 | 6 | 3 |
| TEP475(*)050 | G | 4.7 | 1.8 | 6 | 2.5 |
| TEP685(*)050 | H | 6.8 | 2.7 | 6 | 2 |
| TEP106(*)050 | J | 10 | 4 | 8 | 1.6 |
| TEP156(*)050 | K | 15 | 6 | 8 | 1.2 |
| TEP226(*)050 | L | 22 | 8.8 | 8 | 1 |

Dipped Radial Capacitors



Tape and Reel Packaging

SOLID TANTALUM RESIN DIPPED TAP/TEP

TAPE AND REEL PACKAGING FOR AUTOMATIC COMPONENT INSERTION

TAP/TEP types are all offered on radial tape, in reel or 'ammo' pack format for use on high speed radial automatic insertion equipment, or preforming machines.

The tape format is compatible with EIA 468A standard for component taping set out by major manufacturers of radial automatic insertion equipment.

TAP/TEP – available in three formats. See page 124 for dimensions.

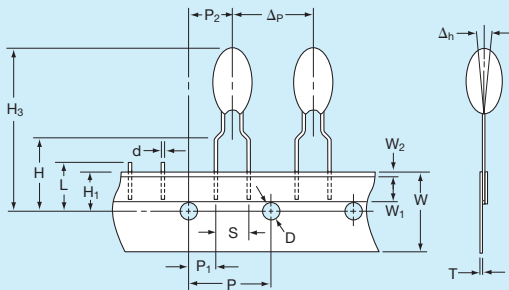

'B' wires for normal automatic insertion on 5mm pitch.

BRW suffix for reel
BRS suffix for 'ammo' pack
Available in case sizes A - J

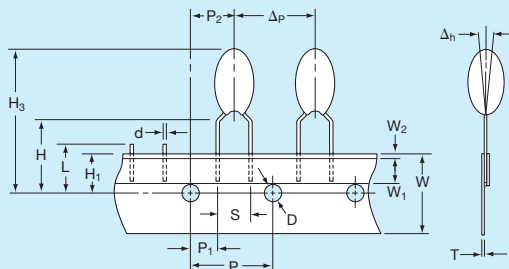

'C' wires for preforming.

CRW suffix for reel
CRS suffix for 'ammo' pack
Available in case sizes A - R

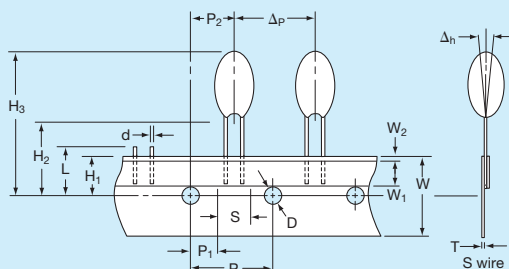

'S' and 'D' wire for special applications, automatic insertion on 2.5mm pitch.

SRW, DTW suffix for reel
SRS, DTS suffix for 'ammo' pack
Available in case sizes A - J

Dipped Radial Capacitors



Tape and Reel Packaging

SOLID TANTALUM RESIN DIPPED TAP/TEP

CASE DIMENSIONS: millimeters (inches)

| Description | Code | Dimension |
|---------------------------------|----------------|--|
| Feed hole pitch | P | 12.7 ± 0.30 (0.500 ± 0.010) |
| Hole center to lead | P ₁ | 3.85 ± 0.70 (0.150 ± 0.030) to be measured at bottom of clench |
| | | 5.05 ± 1.00 (0.200 ± 0.040) for S wire |
| Hole center to component center | P ₂ | 6.35 ± 0.40 (0.250 ± 0.020) |
| Change in pitch | Δp | ± 1.00 (± 0.040) |
| Lead diameter | d | 0.50 ± 0.05 (0.020 ± 0.003) |
| Lead spacing | S | See wire form table |
| Component alignment | Δh | 0 ± 2.00 (0 ± 0.080) |
| Feed hole diameter | D | 4.00 ± 0.20 (0.150 ± 0.008) |
| Tape width | W | 18.0 + 1.00 (0.700 + 0.040) - 0.50 - 0.020) |
| Hold down tape width | W ₁ | 6.00 (0.240) min. |
| Hold down tape position | W ₂ | 1.00 (0.040) max. |
| Lead wire clench height | H | 16.0 ± 0.50 (0.630 ± 0.020) |
| | | 19.0 ± 1.00 (0.750 ± 0.040) on request |
| Hole position | H ₁ | 9.00 ± 0.50 (0.350 ± 0.020) |
| Base of component height | H ₂ | 18.0 (0.700) min. (S wire only) |
| Component height | H ₃ | 32.25 (1.300) max. |
| Length of snipped lead | L | 11.0 (0.430) max. |
| Total tape thickness | T | 0.70 ± 0.20 (0.030 ± 0.001) |
| | | Carrying card 0.50 ± 0.10 (0.020 ± 0.005) |

REEL CONFIGURATION AND DIMENSIONS: millimeters (inches)

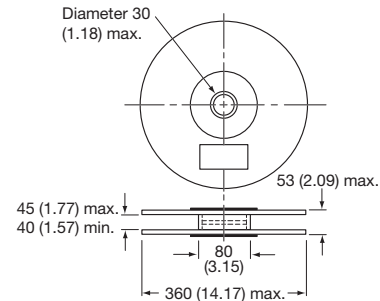

Manufactured from cardboard with plastic hub.

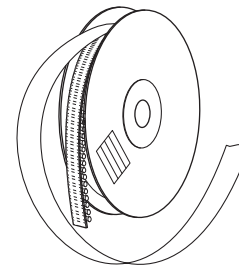

Holding tape outside. Positive terminal leading.

PACKAGING QUANTITIES

For Reels

| Style | Case size | No. of pieces |
|------------|------------------|---------------|
| TAP TEP | A | 1500 |
| | B, C, D | 1250 |
| | E, F | 1000 |
| | G, H, J | 750 |
| | K, L, M, N, P, R | 500 |

For 'Ammo' pack

| Style | Case size | No. of pieces |
|------------|------------------|---------------|
| TAP TEP | A, B, C, D | 3000 |
| | E, F, G | 2500 |
| | H, J | 2000 |
| | K, L, M, N, P, R | 1000 |

For bulk products

| Style | Case size | No. of pieces |
|------------|-----------|---------------|
| TAP TEP | A to H | 1000 |
| | J to L | 500 |
| | M to R | 100 |

AMMO PACK DIMENSIONS

millimeters (inches) max.

Height 360 (14.17), width 360 (14.17), thickness 60 (2.36)

GENERAL NOTES

Resin dipped tantalum capacitors are only available taped in the range of case sizes and in the modular quantities by case size as indicated.

Packaging quantities on tape may vary by ±1%.

Section 4: Technical Summary and Application Guidelines



INTRODUCTION

Tantalum capacitors are manufactured from a powder of pure tantalum metal. OxiCap® - niobium oxide capacitor is made from niobium oxide NbO powder. The typical particle size is between 2 and 10 μm.

Figure below shows typical powders. Note the very great difference in particle size between the powder CVs/g.

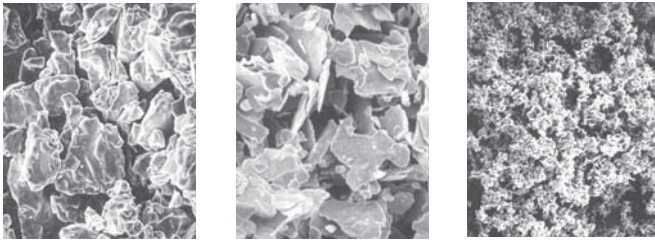

4000μFV

20000μFV

50000μFV

Figure 1a. Tantalum powder

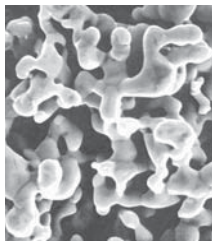

Figure 1b. Niobium Oxide powder

The powder is compressed under high pressure around a Tantalum or Niobium wire (known as the Riser Wire) to form a “pellet”. The riser wire is the anode connection to the capacitor.

This is subsequently vacuum sintered at high temperature (typically 1200 - 1800°C) which produces a mechanically strong pellet and drives off any impurities within the powder.

During sintering the powder becomes a sponge like structure with all the particles interconnected in a huge lattice.

This structure is of high mechanical strength and density, but is also highly porous giving a large internal surface area (see Figure 2).

The larger the surface area the larger the capacitance. Thus high CV/g (capacitance voltage product per gram) powders, which have a low average particle size, are used for low voltage, high capacitance parts.

By choosing which powder and sinter temperature is used to produce each capacitance/voltage rating the surface area can be controlled.

The following example uses a 220μF 6V capacitor to illustrate the point.

$$C = \frac{\epsilon_0 \epsilon_r A}{d}$$

where ϵ_0 is the dielectric constant of free space (8.855 x 10⁻¹² Farads/m)

ϵ_r is the relative dielectric constant

= 27 for Tantalum Pentoxide

= 41 for Niobium Pentoxide

d is the dielectric thickness in meters

C is the capacitance in Farads

and A is the surface area in meters

Rearranging this equation gives:

$$A = \frac{Cd}{\epsilon_0 \epsilon_r}$$

thus for a 220μF/6V capacitor the surface area is 346 square centimeters, or nearly a half times the size of this page.

The dielectric is then formed over all the Tantalum or niobium oxide surfaces by the electrochemical process of anodization. To activate this, the “pellet” is dipped into a very weak solution of phosphoric acid.

The dielectric thickness is controlled by the voltage applied during the forming process. Initially the power supply is kept in a constant current mode until the correct thickness of dielectric has been reached (that is the voltage reaches the ‘forming voltage’), it then switches to constant voltage mode and the current decays to close to zero.

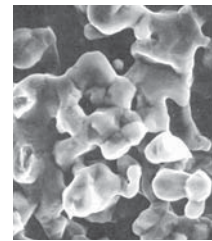
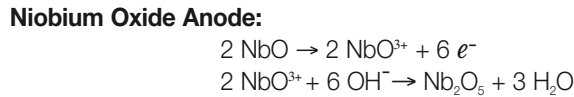
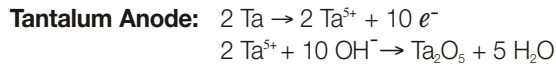

Figure 2. Sintered Anode

Technical Summary and Application Guidelines



The chemical equations describing the process are as follows:



Cathode:

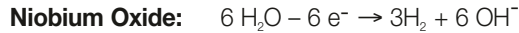
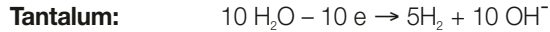

The oxide forms on the surface of the Tantalum or Niobium Oxide but it also grows into the material. For each unit of oxide two thirds grows out and one third grows in. It is for this reason that there is a limit on the maximum voltage rating of Tantalum & Niobium Oxide capacitors with present technology powders (see Figure 3).

The dielectric operates under high electrical stress. Consider a 220µF 6V part:

Formation voltage = Formation Ratio x Working Voltage
 = 3.5 x 6
 = 21 Volts

Tantalum:

The pentoxide (Ta_2O_5) dielectric grows at a rate of 1.7×10^{-9} m/V

Dielectric thickness (d) = $21 \times 1.7 \times 10^{-9}$
 = 0.036 µm

Electric Field strength = Working Voltage / d
 = 167 KV/mm

Niobium Oxide:

The niobium oxide (Nb_2O_5) dielectric grows at a rate of 2.4×10^{-9} m/V

Dielectric thickness (d) = $21 \times 2.4 \times 10^{-9}$
 = 0.050 µm

Electric Field strength = Working Voltage / d
 = 120 KV/mm

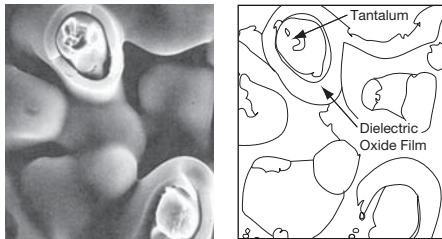
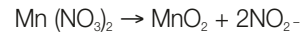

Figure 3. Dielectric layer

The next stage is the production of the cathode plate. This is achieved by pyrolysis of Manganese Nitrate into Manganese Dioxide.

The “pellet” is dipped into an aqueous solution of nitrate and then baked in an oven at approximately 250°C to produce the dioxide coat. The chemical equation is:



This process is repeated several times through varying specific densities of nitrate to build up a thick coat over all internal and external surfaces of the “pellet”, as shown in Figure 4.

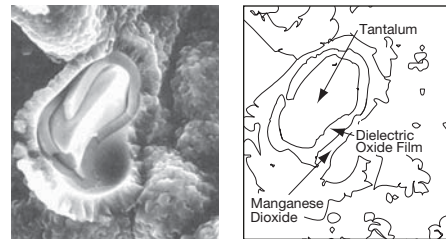

Figure 4. Manganese Dioxide Layer

The “pellet” is then dipped into graphite and silver to provide a good connection to the Manganese Dioxide cathode plate. Electrical contact is established by deposition of carbon onto the surface of the cathode. The carbon is then coated with a conductive material to facilitate connection to the cathode termination (see Figure 5). Packaging is carried out to meet individual specifications and customer requirements. This manufacturing technique is adhered to for the whole range of AVX Tantalum capacitors, which can be subdivided into four basic groups: Chip / Resin dipped / Rectangular boxed / Axial.

Further information on production of Tantalum Capacitors can be obtained from the technical paper “Basic Tantalum Technology”, by John Gill, available from your local AVX representative.

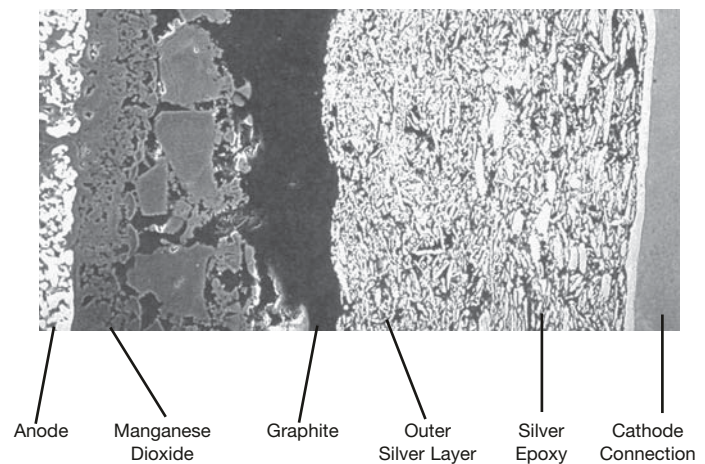

Figure 5. Cathode Termination



Technical Summary and Application Guidelines



SECTION 1 ELECTRICAL CHARACTERISTICS AND EXPLANATION OF TERMS

1.1 CAPACITANCE

1.1.1 Rated capacitance (C_R).

This is the nominal rated capacitance. For tantalum and OxiCap® capacitors it is measured as the capacitance of the equivalent series circuit at 25°C using a measuring bridge supplied by a 0.5V rms 120Hz sinusoidal signal, free of harmonics with a bias of 2.2Vd.c.

1.1.2 Capacitance tolerance.

This is the permissible variation of the actual value of the capacitance from the rated value. For additional reading, please consult the AVX technical publication "Capacitance Tolerances for Solid Tantalum Capacitors".

1.1.3 Temperature dependence of capacitance.

The capacitance of a tantalum capacitor varies with temperature. This variation itself is dependent to a small extent on the rated voltage and capacitor size.

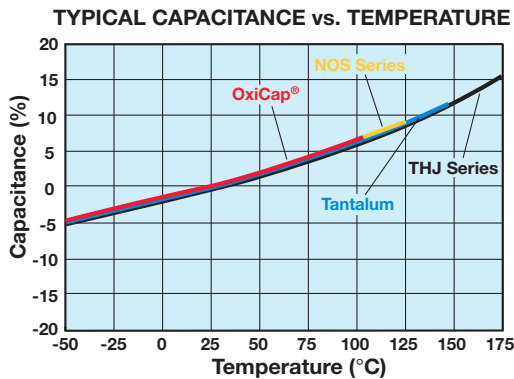

1.1.4 Frequency dependence of the capacitance.

The effective capacitance decreases as frequency increases. Beyond 100kHz the capacitance continues to drop until resonance is reached (typically between 0.5 - 5MHz depending on the rating). Beyond the resonant frequency the device becomes inductive.

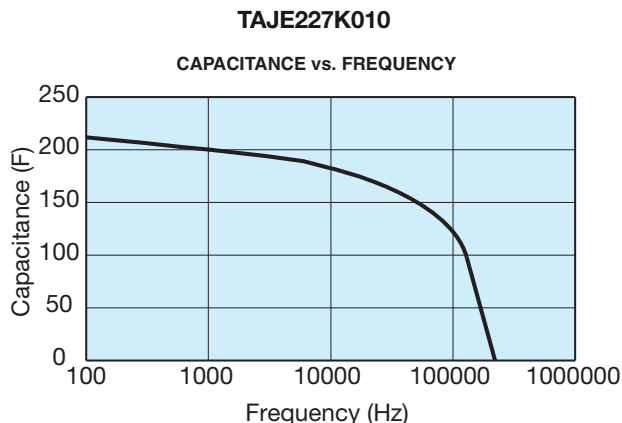

For individual part number please refer to SpiTan Software for frequency and temperature behavior found on AVX Corporation website.

1.2 VOLTAGE

1.2.1 Rated d.c. voltage (V_R).

This is the rated d.c. voltage for continuous operation up to 85°C (up to 40°C for TLJ, TLN, NLJ series).

Operating voltage consists of the sum of DC bias voltage and ripple peak voltage. The peak voltage should not exceed the category voltage. For recommended voltage (application) derating refer to figure 2c of the SECTION 3.

1.2.2 Category voltage (V_C).

This is the maximum voltage that may be applied continuously to a capacitor. It is equal to the rated voltage up to +85°C (up to 40°C for TLJ, TLN, NLJ series), beyond which it is subject to a linear derating, to 2/3 V_R at 125°C for tantalum and 2/3 V_R at 105°C for OxiCap®.

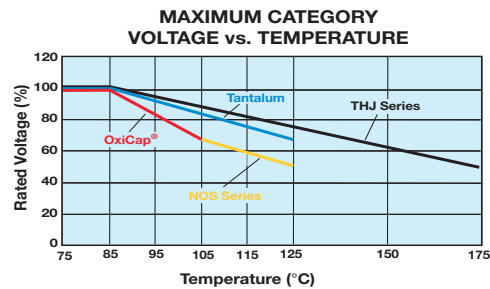

1.2.3 Surge voltage (V_S).

This is the highest voltage that may be applied to a capacitor for short periods of time in circuits with minimum series resistance of 33Ohms (CECC states 1kΩ). The surge voltage may be applied up to 10 times in an hour for periods of up to 30 seconds at a time. The surge voltage must not be used as a parameter in the design of circuits in which, in the normal course of operation, the capacitor is periodically charged and discharged.

| 85°C Tantalum | | 125°C Tantalum* | |
|---------------------|---------------------|------------------------|---------------------|
| Rated Voltage V_R | Surge Voltage V_S | Category Voltage V_C | Surge Voltage V_S |
| 2 | 2.7 | 1.3 | 1.7 |
| 2.5 | 3.3 | 1.7 | 2.2 |
| 3 | 3.9 | 2 | 2.6 |
| 4 | 5.2 | 2.7 | 3.4 |
| 5 | 6.5 | 3.3 | 4 |
| 6.3 | 8 | 4 | 5 |
| 10 | 13 | 7 | 8 |
| 16 | 20 | 10 | 13 |
| 20 | 26 | 13 | 16 |
| 25 | 32 | 17 | 20 |
| 35 | 46 | 23 | 28 |
| 50 | 65 | 33 | 40 |

| 85°C OxiCap® | | 105°C OxiCap® | |
|---------------------|---------------------|------------------------|---------------------|
| Rated Voltage V_R | Surge Voltage V_S | Category Voltage V_C | Surge Voltage V_S |
| 1.8 | 2.3 | 1.2 | 1.6 |
| 2.5 | 3.3 | 1.7 | 2.2 |
| 4 | 5.2 | 2.7 | 3.4 |
| 6.3 | 8 | 4 | 5 |
| 10 | 13 | 7 | 8 |

*For THJ 175°C Category & Surge voltage see THJ section on pages 91-93.



Technical Summary and Application Guidelines



1.2.4 Effect of surges

The solid Tantalum and OxiCap® capacitors have a limited ability to withstand voltage and current surges. This is in common with all other electrolytic capacitors and is due to the fact that they operate under very high electrical stress across the dielectric. For example a 6 volt tantalum capacitor has an Electrical Field of 167 kV/mm when operated at rated voltage. OxiCap® capacitors operate at electrical field significantly less than 167 kV/mm.

It is important to ensure that the voltage across the terminals of the capacitor never exceeds the specified surge voltage rating.

Solid tantalum capacitors and OxiCap® have a self healing ability provided by the Manganese Dioxide semiconducting layer used as the negative plate. However, this is limited in low impedance applications. In the case of low impedance circuits, the capacitor is likely to be stressed by current surges.

Derating the capacitor increases the reliability of the component. (See Figure 2b page 135). The “AVX Recommended Derating Table” (page 137) summarizes voltage rating for use on common voltage rails, in low impedance applications for both Tantalum and OxiCap® capacitors.

In circuits which undergo rapid charge or discharge a protective resistor of 1Ω/V is recommended. If this is impossible, a derating factor of up to 70% should be used on tantalum capacitors. OxiCap® capacitors can be used with derating of 20% minimum.

In such situations a higher voltage may be needed than is available as a single capacitor. A series combination should be used to increase the working voltage of the equivalent capacitor: For example, two 22μF 25V parts in series is equivalent to one 11μF 50V part. For further details refer to J.A. Gill's paper “Investigation into the Effects of Connecting Tantalum Capacitors in Series”, available from AVX offices worldwide.

NOTE:

While testing a circuit (e.g. at ICT or functional) it is likely that the capacitors will be subjected to large voltage and current transients, which will not be seen in normal use. These conditions should be borne in mind when considering the capacitor's rated voltage for use. These can be controlled by ensuring a correct test resistance is used.

1.2.5 Reverse voltage and Non-Polar operation.

The values quoted are the maximum levels of reverse voltage which should appear on the capacitors at any time. These limits are based on the assumption that the capacitors are polarized in the correct direction for the majority of their working life. They are intended to cover short term reversals of polarity such as those occurring during switching transients or during a minor portion of an impressed waveform. Continuous application of reverse voltage without normal polarization will result in a degradation of leakage current. In conditions under which continuous application of a reverse

voltage could occur two similar capacitors should be used in a back-to-back configuration with the negative terminations connected together. Under most conditions this combination will have a capacitance one half of the nominal capacitance of either capacitor. Under conditions of isolated pulses or during the first few cycles, the capacitance may approach the full nominal value. The reverse voltage ratings are designed to cover exceptional conditions of small level excursions into incorrect polarity. The values quoted are not intended to cover continuous reverse operation.

The peak reverse voltage applied to the capacitor must not exceed:

10% of the rated d.c. working voltage to a maximum of 1.0v at 25°C

3% of the rated d.c. working voltage to a maximum of 0.5v at 85°C

1% of the rated d.c. working voltage to a maximum of 0.1v at 125°C (0.1v at 150°C THJ Series)

Note: Capacitance and DF values of OxiCap® may exceed specification limits under these conditions.

LEAKAGE CURRENT vs. BIAS VOLTAGE

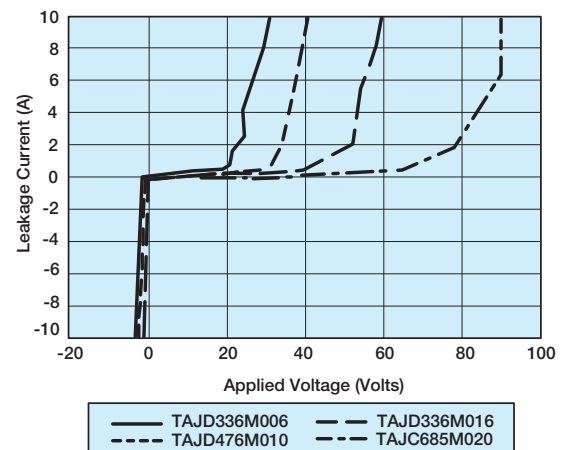

1.2.6 Superimposed A.C. Voltage (Vr.m.s.) - Ripple Voltage.

This is the maximum r.m.s. alternating voltage; superimposed on a d.c. voltage, that may be applied to a capacitor. The sum of the d.c. voltage and peak value of the superimposed a.c. voltage must not exceed the category voltage, v.c.

Full details are given in Section 2.

1.2.7 Forming voltage.

This is the voltage at which the anode oxide is formed. The thickness of this oxide layer is proportional to the formation voltage for a capacitor and is a factor in setting the rated voltage.



1.3 DISSIPATION FACTOR AND TANGENT OF LOSS ANGLE (TAN D)

1.3.1 Dissipation factor (D.F.).

Dissipation factor is the measurement of the tangent of the loss angle ($\tan \delta$) expressed as a percentage. The measurement of DF is carried out using a measuring bridge that supplies a 0.5V rms 120Hz sinusoidal signal, free of harmonics with a bias of 2.2Vdc. The value of DF is temperature and frequency dependent.

Note: For surface mounted products the maximum allowed DF values are indicated in the ratings table and it is important to note that these are the limits met by the component AFTER soldering onto the substrate.

1.3.2 Tangent of Loss Angle ($\tan \delta$).

This is a measurement of the energy loss in the capacitor. It is expressed, as $\tan \delta$ and is the power loss of the capacitor divided by its reactive power at a sinusoidal voltage of specified frequency. Terms also used are power factor, loss factor and dielectric loss. $\cos(90 - \delta)$ is the true power factor. The measurement of $\tan \delta$ is carried out using a measuring bridge that supplies a 0.5V rms 120Hz sinusoidal signal, free of harmonics with a bias of 2.2Vdc.

1.3.3 Frequency dependence of Dissipation Factor.

Dissipation Factor increases with frequency as shown in the typical curves that are for tantalum and OxiCap® capacitors identical:

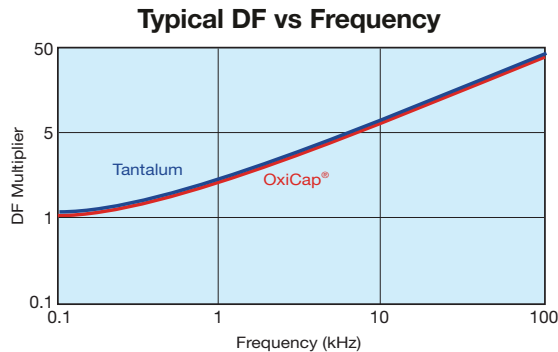

1.3.4 Temperature dependence of Dissipation Factor.

Dissipation factor varies with temperature as the typical curves show. These plots are identical for both Tantalum and OxiCap® capacitors. For maximum limits please refer to ratings tables.

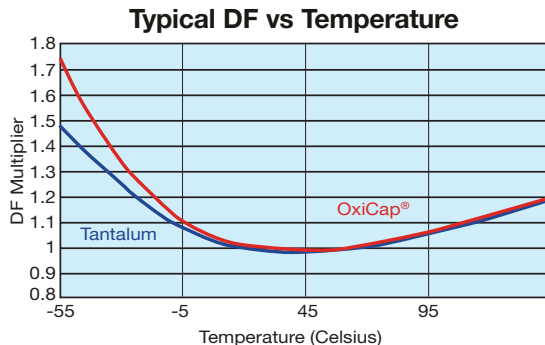

1.4 IMPEDANCE, (Z) AND EQUIVALENT SERIES RESISTANCE (ESR)

1.4.1 Impedance, Z.

This is the ratio of voltage to current at a specified frequency. Three factors contribute to the impedance of a Tantalum capacitor; the resistance of the semiconductor layer; the capacitance value and the inductance of the electrodes and leads.

At high frequencies the inductance of the leads becomes a limiting factor. The temperature and frequency behavior of these three factors of impedance determine the behavior of the impedance Z. The impedance is measured at 25°C and 100kHz.

1.4.2 Equivalent Series Resistance, ESR.

Resistance losses occur in all practical forms of capacitors. These are made up from several different mechanisms, including resistance in components and contacts, viscous forces within the dielectric and defects producing bypass current paths. To express the effect of these losses they are considered as the ESR of the capacitor. The ESR is frequency dependent and can be found by using the relationship;

$$ESR = \frac{\tan \delta}{2\pi f C}$$

Where f is the frequency in Hz, and C is the capacitance in farads.

The ESR is measured at 25°C and 100kHz.

ESR is one of the contributing factors to impedance, and at high frequencies (100kHz and above) it becomes the dominant factor. Thus ESR and impedance become almost identical, impedance being only marginally higher.

1.4.3 Frequency dependence of Impedance and ESR.

ESR and Impedance both increase with decreasing frequency. At lower frequencies the values diverge as the extra contributions to impedance (due to the reactance of the capacitor) become more significant. Beyond 1MHz (and beyond the resonant point of the capacitor) impedance again increases due to the inductance of the capacitor. Typical ESR and Impedance values are similar for both tantalum and niobium oxide materials and thus the same charts are valid for both for Tantalum and OxiCap® capacitors.

Typical ESR vs Frequency

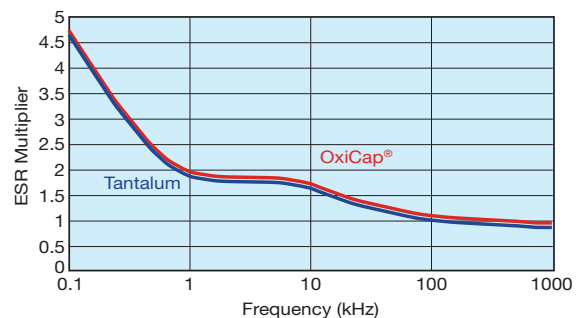

Typical Impedance vs Frequency

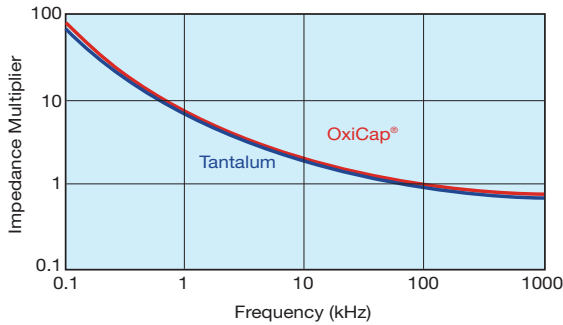

1.4.4 Temperature dependence of the Impedance and ESR.

At 100kHz, impedance and ESR behave identically and decrease with increasing temperature as the typical curves show.

Typical 100kHz ESR vs Temperature

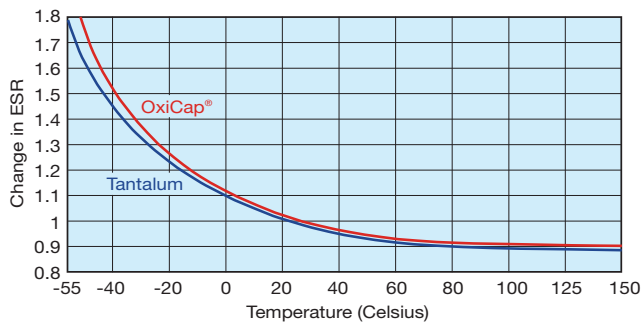

1.5 D.C. LEAKAGE CURRENT

1.5.1 Leakage current.

The leakage current is dependent on the voltage applied, the elapsed time since the voltage was applied and the component temperature. It is measured at +20°C with the rated voltage applied. A protective resistance of 1000Ω is connected in series with the capacitor in the measuring circuit. Three to five minutes after application of the rated voltage the leakage current must not exceed the maximum values indicated in the ratings table. Leakage current is referenced as DCL (for Direct Current Leakage). The default maximum limit for DCL Current is given by $DCL = 0.01CV$, where DCL is in microamperes, and C is the capacitance rating in microfarads, and V is the voltage rating in volts. DCL of tantalum capacitors vary within range of 0.01 - 0.1CV or 0.5μA (whichever is the greater). And 0.02 - 0.1CV or 1.0μA (whichever is the greater) for OxiCap® capacitors.

Reforming of Tantalum or OxiCap® capacitors is unnecessary even after prolonged storage periods without the application of voltage.

1.5.2 Temperature dependence of the leakage current.

The leakage current increases with higher temperatures; typical values are shown in the graph. For operation between 85°C and 125°C, the maximum working voltage must be derated and can be found from the following formula.

$$V_{max} = \left(1 - \frac{T - 85}{125}\right) \times V_R$$

where T is the required operating temperature.

LEAKAGE CURRENT vs. TEMPERATURE

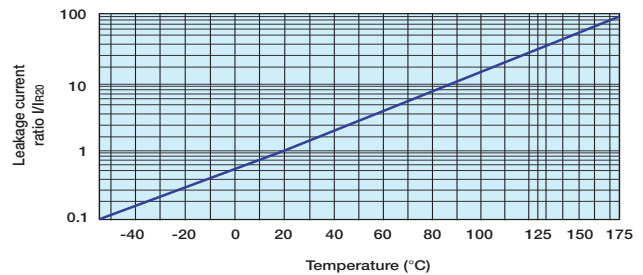

1.5.3 Voltage dependence of the leakage current.

The leakage current drops rapidly below the value corresponding to the rated voltage V_R when reduced voltages are applied. The effect of voltage derating on the leakage current is shown in the graph. This will also give a significant increase in the reliability for any application. See Section 3.1 (page 135) for details.

LEAKAGE CURRENT vs. RATED VOLTAGE

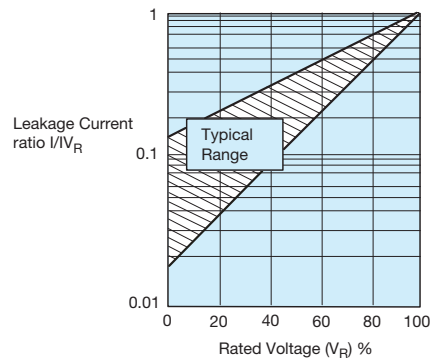

For input condition of fixed application voltage and including median curve of the Leakage current vs. Rated voltage graph displayed above we can evaluate following curve.

Technical Summary and Application Guidelines



LEAKAGE CURRENT MULTIPLIER vs. VOLTAGE DERATING for FIXED APPLICATION VOLTAGE V_A

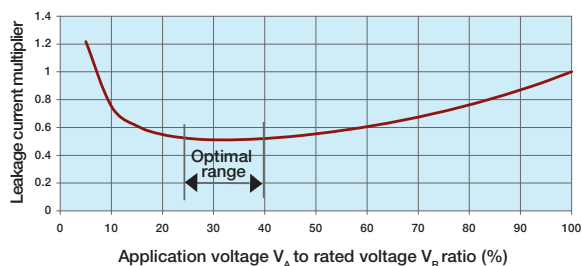

We can identify the range of V_A/V_R (derating) values with minimum actual DCL as the “optimal” range. Therefore the minimum DCL is obtained when capacitor is used at 25 to 40 % of rated voltage - when the rated voltage of the capacitor is 2.5 to 4 times higher than actual application voltage.

For additional information on Leakage Current, please consult the AVX technical publication “Analysis of Solid Tantalum Capacitor Leakage Current” by R. W. Franklin.

1.5.4 Ripple current.

The maximum ripple current allowed is derived from the power dissipation limits for a given temperature rise above ambient temperature (please refer to Section 2, pages 132-134).

1.6 SELF INDUCTANCE (ESL)

The self-inductance value (ESL) can be important for resonance frequency evaluation. See figure below typical ESL values per case size.

TAJ/TPS/TRJ/THJ/TAW/TLJ/TCJ/NLJ/NOJ/NOS

| Case Size | Typical Self Inductance value (nH) | Case Size | Typical Self Inductance value (nH) | Case Size | Typical Self Inductance value (nH) |
|-----------|------------------------------------|-----------|------------------------------------|-----------|------------------------------------|
| A | 1.8 | H | 1.8 | U | 2.4 |
| B | 1.8 | K | 1.8 | V | 2.4 |
| C | 2.2 | N | 1.4 | W | 2.2 |
| D | 2.4 | P | 1.4 | X | 2.4 |
| E | 2.5 | R | 1.4 | Y | 2.4 |
| F | 2.2 | S | 1.8 | | |
| G | 1.8 | T | 1.8 | | |

TAC/TLC/TPC

| Case Size | Typical Self-Inductance value (nH) |
|-----------|------------------------------------|
| K | 1.1 |
| L | 1.2 |
| R | 1.4 |

TCM/TPM TRM/NOM

| Case Size | Typical Self-Inductance value (nH) |
|-----------|------------------------------------|
| D | 1.0 |
| E | 2.5 |
| V | 2.4 |
| Y | 1.0 |

TLN/TCN

| Case Size | Typical Self-Inductance value (nH) |
|-----------|------------------------------------|
| K | 1.0 |
| L | 1.0 |
| S | 1.0 |
| T | 1.0 |
| 4 | 2.2 |
| 6 | 2.5 |

SECTION 2

A.C. OPERATION, RIPPLE VOLTAGE AND RIPPLE CURRENT

2.1 RIPPLE RATINGS (A.C.)

In an a.c. application heat is generated within the capacitor by both the a.c. component of the signal (which will depend upon the signal form, amplitude and frequency), and by the d.c. leakage. For practical purposes the second factor is insignificant. The actual power dissipated in the capacitor is calculated using the formula:

$$P = I^2 R$$

and rearranged to $I = \text{SQRT}(P/R)$ (Eq. 1)

where I = rms ripple current, amperes
 R = equivalent series resistance, ohms
 U = rms ripple voltage, volts
 P = power dissipated, watts
 Z = impedance, ohms, at frequency under consideration

Maximum a.c. ripple voltage (U_{max}).

From the Ohms' law equation:

$$U_{\text{max}} = IR \text{(Eq. 2)}$$

Where P is the maximum permissible power dissipated as listed for the product under consideration (see tables).

However care must be taken to ensure that:

1. The d.c. working voltage of the capacitor must not be exceeded by the sum of the positive peak of the applied a.c. voltage and the d.c. bias voltage.
2. The sum of the applied d.c. bias voltage and the negative peak of the a.c. voltage must not allow a voltage reversal in excess of the "Reverse Voltage".

Historical ripple calculations.

Previous ripple current and voltage values were calculated using an empirically derived power dissipation required to give a 10°C rise of the capacitors body temperature from room temperature, usually in free air. These values are shown in Table I. Equation 1 then allows the maximum ripple current to be established, and Equation 2, the maximum ripple voltage. But as has been shown in the AVX article on thermal management by I. Salisbury, the thermal conductivity of a Tantalum chip capacitor varies considerably depending upon how it is mounted.

Table I: Power Dissipation Ratings (In Free Air)

TAJ/TPS/TPM/TRJ/TRM/THJ/TAW/TLJ/TLN/TCJ/TCM
TCN/NLJ/NOJ/NOS/NOM Series Molded Chip

| Case size | Max. power dissipation (W) | | | | |
|-----------|-----------------------------|---------|-------------|-------------|-------|
| | Tantalum | | | OxiCap® | |
| | TAJ/TPS/TRJ/THJ/TAW/TLJ/TCJ | TLN TCN | TPM TRM TCM | NLJ NOJ NOS | NOM |
| A | 0.075 | — | — | 0.090 | — |
| B | 0.085 | — | — | 0.102 | — |
| C | 0.110 | — | — | 0.132 | — |
| D | 0.150 | — | 0.255 | 0.180 | — |
| E | 0.165 | — | 0.270 | 0.198 | 0.324 |
| F | 0.100 | — | — | 0.120 | — |
| G | 0.070 | 0.060 | — | 0.084 | — |
| H | 0.080 | 0.070 | — | 0.096 | — |
| K | 0.065 | 0.055 | — | 0.078 | — |
| L | 0.070 | 0.060 | — | 0.084 | — |
| M | — | 0.040 | — | — | — |
| N | 0.050 | 0.040 | — | — | — |
| P | 0.060 | — | — | 0.072 | — |
| R | 0.055 | 0.045 | — | 0.066 | — |
| S | 0.065 | 0.055 | — | 0.078 | — |
| T | 0.080 | 0.070 | — | 0.096 | — |
| U | 0.165 | — | — | — | — |
| V | 0.250 | — | 0.285 | 0.300 | — |
| W | 0.090 | — | — | 0.108 | — |
| X | 0.100 | — | — | 0.120 | — |
| Y | 0.125 | 0.115 | 0.210 | 0.150 | — |
| Z | — | — | 0.300 | — | — |
| 4 | — | 0.165 | — | — | — |
| 6 | — | 0.230 | — | — | — |

TACmicrochip®

| Case size | Max. power dissipation (W) |
|-----------|----------------------------|
| A | 0.040 |
| B | 0.040 |
| H | 0.040 |
| J | 0.020 |
| K | 0.015 |
| L | 0.025 |
| M | 0.030 |
| Q | 0.040 |
| R | 0.045 |
| T | 0.040 |
| U | 0.035 |
| V | 0.035 |
| X | 0.040 |
| Z | 0.020 |

NLJ/NOJ/NOS/NOM

| Temperature correction factor for ripple current | |
|--|--------|
| Temp. °C | Factor |
| +25 | 1.00 |
| +55 | 0.95 |
| +85 | 0.90 |
| +105 | 0.40 |
| +125 (NOS,NOM) | 0.40 |

TAJ/TPS/TPM/TRJ/TRM/THJ/TAW
TLJ/TLN/TCJ/TCM/TCN

| Temp °C | Correction Factor for ripple current | Correction Factor for Power Dissipation | Max. Temperature rise °C |
|------------|--------------------------------------|---|--------------------------|
| +25 | 1.00 | 1.00 | 10 |
| +55 | 0.95 | 0.90 | 9 |
| +85 | 0.90 | 0.81 | 8.1 |
| +105 | 0.65 | 0.42 | 4.2 |
| +115 | 0.49 | 0.24 | 2.4 |
| +125 | 0.40 | 0.16 | 1.6 |
| +175 (THJ) | 0.20 | 0.04 | 0.4 |
| +200 (THJ) | 0.10 | 0.01 | 0.1 |

Technical Summary and Application Guidelines



A piece of equipment was designed which would pass sine and square wave currents of varying amplitudes through a biased capacitor. The temperature rise seen on the body for the capacitor was then measured using an infra-red probe. This ensured that there was no heat loss through any thermo-couple attached to the capacitor's surface.

Results for the C, D and E case sizes

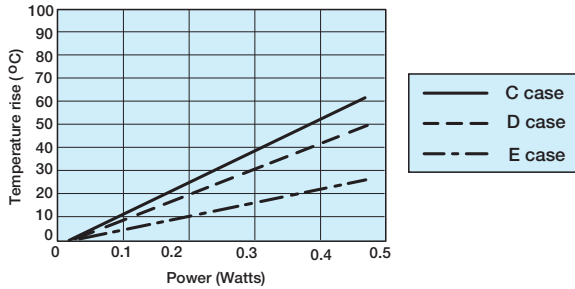

Several capacitors were tested and the combined results are shown above. All these capacitors were measured on FR4 board, with no other heat sinking. The ripple was supplied at various frequencies from 1kHz to 1MHz.

As can be seen in the figure above, the average P_{max} value for the C case capacitors was 0.11 Watts. This is the same as that quoted in Table I.

The D case capacitors gave an average P_{max} value 0.125 Watts. This is lower than the value quoted in the Table I by 0.025 Watts. The E case capacitors gave an average P_{max} of 0.200 Watts that was much higher than the 0.165 Watts from Table I.

If a typical capacitor's ESR with frequency is considered, e.g. figure below, it can be seen that there is variation. Thus for a set ripple current, the amount of power to be dissipated by the capacitor will vary with frequency. This is clearly shown in figure in top of next column, which shows that the surface temperature of the unit raises less for a given value of ripple current at 1MHz than at 100kHz.

The graph below shows a typical ESR variation with frequency. Typical ripple current versus temperature rise for 100kHz and 1MHz sine wave inputs.

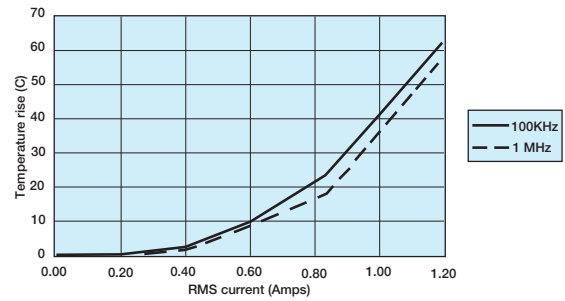
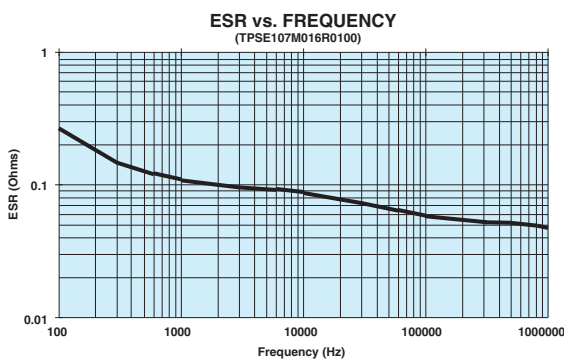

If I^2R is then plotted it can be seen that the two lines are in fact coincident, as shown in figure below.

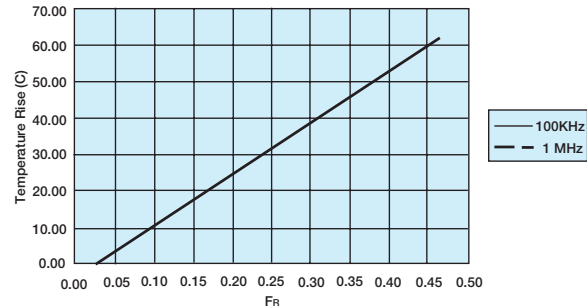

Example

A Tantalum capacitor is being used in a filtering application, where it will be required to handle a 2 Amp peak-to-peak, 200kHz square wave current.

A square wave is the sum of an infinite series of sine waves at all the odd harmonics of the square waves fundamental frequency. The equation which relates is:

$$I_{square} = I_{pk} \sin(2\pi f) + I_{pk} \sin(6\pi f) + I_{pk} \sin(10\pi f) + I_{pk} \sin(14\pi f) + \dots$$

Thus the special components are:

| Frequency | Peak-to-peak current (Amps) | RMS current (Amps) |
|-----------|-----------------------------|--------------------|
| 200 KHz | 2.000 | 0.707 |
| 600 KHz | 0.667 | 0.236 |
| 1 MHz | 0.400 | 0.141 |
| 1.4 MHz | 0.286 | 0.101 |

Let us assume the capacitor is a TAJD686M006
Typical ESR measurements would yield.

| Frequency | Typical ESR (Ohms) | Power (Watts) $I_{rms}^2 \times ESR$ |
|-----------|--------------------|--------------------------------------|
| 200 KHz | 0.120 | 0.060 |
| 600 KHz | 0.115 | 0.006 |
| 1 MHz | 0.090 | 0.002 |
| 1.4 MHz | 0.100 | 0.001 |

Thus the total power dissipation would be 0.069 Watts.

From the D case results shown in figure top of previous column, it can be seen that this power would cause the capacitors surface temperature to rise by about 5°C. For additional information, please refer to the AVX technical publication "Ripple Rating of Tantalum Chip Capacitors" by R.W. Franklin.

Technical Summary and Application Guidelines



2.2 OXICAP RIPPLE RATING

OxiCap® capacitors showing 20% higher power dissipation allowed compared to tantalum capacitors as a result of twice higher specific heat of niobium oxide compared to Tantalum

powders. (Specific heat is related to energy necessary to heat a defined volume of material to a specified temperature.)

2.3 THERMAL MANAGEMENT

The heat generated inside a tantalum capacitor in a.c. operation comes from the power dissipation due to ripple current. It is equal to I^2R , where I is the rms value of the current at a given frequency, and R is the ESR at the same frequency with an additional contribution due to the leakage current. The heat will be transferred from the outer surface by conduction. How efficiently it is transferred from this point is dependent on the thermal management of the board.

In practice, in a high density assembly with no specific thermal management, the power dissipation required to give a 10°C rise above ambient may be up to a factor of 10 less. In these cases, the actual capacitor temperature should be established (either by thermocouple probe or infra-red scanner) and if it is seen to be above this limit it may be necessary to specify a lower ESR part or a higher voltage rating.

The power dissipation ratings given in Section 2.1 (page 132) are based on free-air calculations. These ratings can be approached if efficient heat sinking and/or forced cooling is used.

Please contact application engineering for details or contact the AVX technical publication entitled "Thermal Management of Surface Mounted Tantalum Capacitors" by Ian Salisbury.

Thermal Dissipation from the Mounted Chip

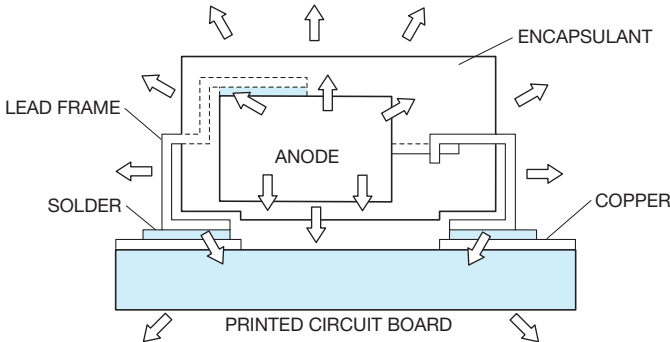

Thermal Impedance Graph with Ripple Current

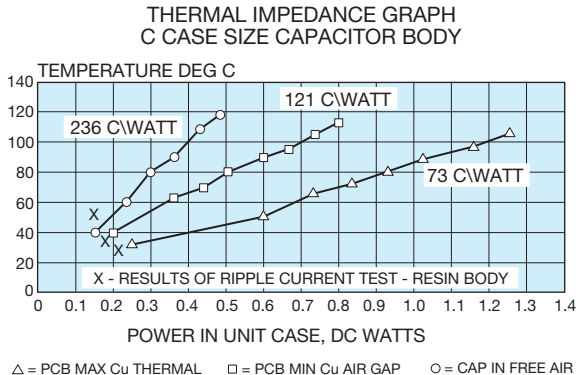

SECTION 3 RELIABILITY AND CALCULATION OF FAILURE RATE

3.1 STEADY-STATE

Both Tantalum and Niobium Oxide dielectric have essentially no wear out mechanism and in certain circumstances is capable of limited self healing. However, random failures can occur in operation. The failure rate of Tantalum capacitors will decrease with time and not increase as with other electrolytic capacitors and other electronic components.

Figure 1. Tantalum and OxiCap® Reliability Curve

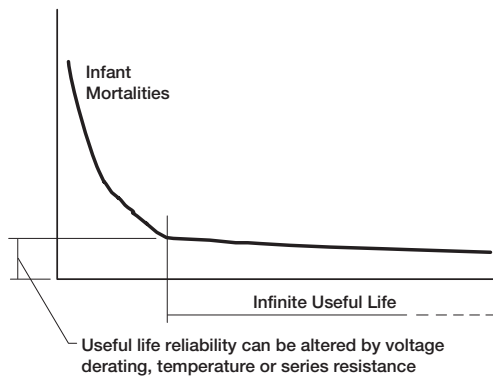

The useful life reliability of the Tantalum and OxiCap® capacitors in steady-state is affected by three factors. The equation from which the failure rate can be calculated is:

$$F = F_V \times F_T \times F_R \times F_B$$

where F_V is a correction factor due to operating voltage/voltage derating

F_T is a correction factor due to operating temperature

F_R is a correction factor due to circuit series resistance

F_B is the basic failure rate level

Base failure rate.

Standard Tantalum conforms to Level M reliability (i.e. 1%/1000 hrs) or better at rated voltage, 85°C and 0.1Ω/volt circuit impedance.

$F_B = 1.0\% / 1000$ hours for TAJ, TPS, TPM, TAW, TCJ, TCM, TCN, TAC

0.5% / 1000 hours for TRJ, TRM, THJ and NOJ

0.2% / 1000 hours for NOS and NOM

TLJ, TLN, TLC and NLJ series of tantalum capacitors are defined at 0.5 x rated voltage at 85°C due to the temperature derating.

$F_B = 0.2\% / 1000$ hours at 85°C and $0.5 \times V_R$ with 0.1Ω/V series impedance with 60% confidence level.

Operating voltage/voltage derating.

If a capacitor with a higher voltage rating than the maximum line voltage is used, then the operating reliability will be improved. This is known as voltage derating.

The graph, Figure 2a, shows the relationship between voltage derating (the ratio between applied and rated voltage) and the failure rate. The graph gives the correction factor F_V for any operating voltage.

Figure 2a. Correction factor to failure rate F_V for voltage derating of a typical component (60% con. level).

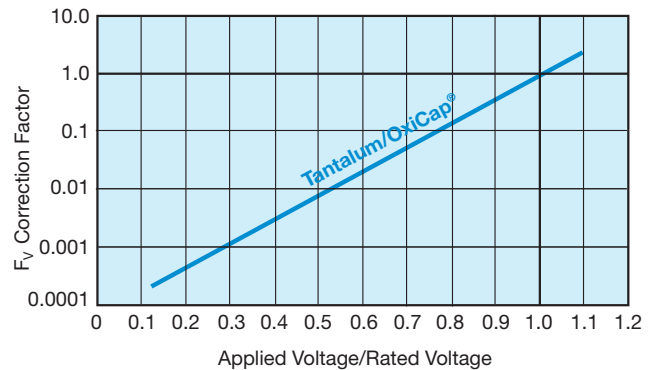

Figure 2b. Gives our recommendation for voltage derating for tantalum capacitors to be used in typical applications.

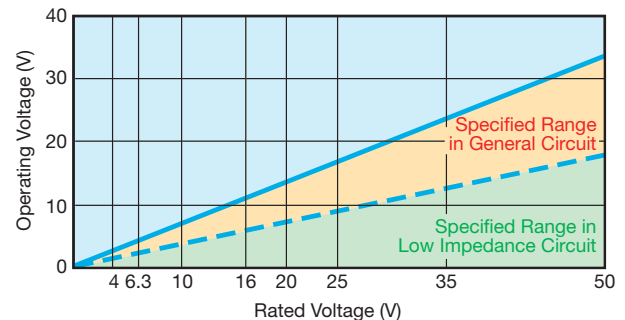
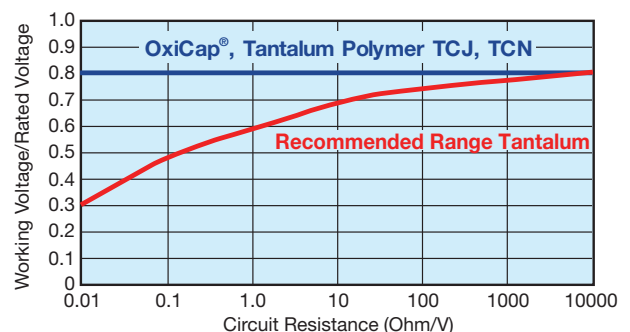

Figure 2c. Gives voltage derating recommendations for tantalum capacitors as a function of circuit impedance.



Technical Summary and Application Guidelines

Operating Temperature.

If the operating temperature is below the rated temperature for the capacitor then the operating reliability will be improved as shown in Figure 3. This graph gives a correction factor F_T for any temperature of operation.

Figure 3: Correction factor to failure rate F_R for ambient temperature T for typical component (60% con. level).

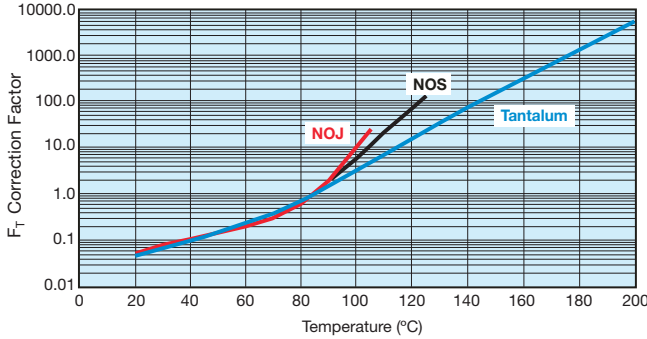

Circuit Impedance.

All solid Tantalum and/or niobium oxide capacitors require current limiting resistance to protect the dielectric from surges. A series resistor is recommended for this purpose. A lower circuit impedance may cause an increase in failure rate, especially at temperatures higher than 20°C. An inductive low impedance circuit may apply voltage surges to the capacitor and similarly a non-inductive circuit may apply current surges to the capacitor, causing localized over-heating and failure. The recommended impedance is 1 Ω per volt. Where this is not feasible, equivalent voltage derating should be used (See MIL HANDBOOK 217E). The graph, Figure 4, shows the correction factor, F_R , for increasing series resistance.

Figure 4. Correction factor to failure rate F_R for series resistance R on basic failure rate F_B for a typical component (60% con. level).

| Circuit resistance ohms/volt | F_R |
|------------------------------|-------|
| 3.0 | 0.07 |
| 2.0 | 0.1 |
| 1.0 | 0.2 |
| 0.8 | 0.3 |
| 0.6 | 0.4 |
| 0.4 | 0.6 |
| 0.2 | 0.8 |
| 0.1 | 1.0 |

For circuit impedances below 0.1 ohms per volt, or for any mission critical application, circuit protection should be considered. An ideal solution would be to employ an AVX SMT thin-film fuse in series.

Example calculation.

Consider a 12 volt power line. The designer needs about 10μF of capacitance to act as a decoupling capacitor near a video bandwidth amplifier. Thus the circuit impedance will be limited only by the output impedance of the board's power unit and the track resistance. Let us assume it to be about 2 Ohms minimum, i.e. 0.167 Ohms/Volt. The operating temperature range is -25°C to +85°C.

If a 10μF 16 Volt capacitor was designed in the operating failure rate would be as follows.

- a) $F_T = 1.0$ @ 85°C
- b) $F_R = 0.85$ @ 0.167 Ohms/Volt
- c) $F_V = 0.08$ @ applied voltage/rated voltage = 75%
- d) $F_B = 1\%/1000$ hours, basic failure rate level

Thus $F = 1.0 \times 0.85 \times 0.08 \times 1 = 0.068\%/1000$ Hours
 If the capacitor was changed for a 20 volt capacitor, the operating failure rate will change as shown.

$F_V = 0.018$ @ applied voltage/rated voltage = 60%
 $F = 1.0 \times 0.85 \times 0.018 \times 1 = 0.0153\%/1000$ Hours

3.2 Dynamic.

As stated in Section 1.2.4 (page 128), the solid capacitor has a limited ability to withstand voltage and current surges. Such current surges can cause a capacitor to fail. The expected failure rate cannot be calculated by a simple formula as in the case of steady-state reliability. The two parameters under the control of the circuit design engineer known to reduce the incidence of failures are derating and series resistance.

The table below summarizes the results of trials carried out at AVX with a piece of equipment, which has very low series resistance with no voltage derating applied. That is if the capacitor was tested at its rated voltage. It has been tested on tantalum capacitors, however the conclusions are valid for both tantalum and OxiCap® capacitors.

Results of production scale derating experiment

| Capacitance and Voltage | Number of units tested | 50% derating applied | No derating applied |
|-------------------------|------------------------|----------------------|---------------------|
| 47μF 16V | 1,547,587 | 0.03% | 1.1% |
| 100μF 10V | 632,876 | 0.01% | 0.5% |
| 22μF 25V | 2,256,258 | 0.05% | 0.3% |

As can clearly be seen from the results of this experiment, the more derating applied by the user, the less likely the probability of a surge failure occurring.

It must be remembered that these results were derived from a highly accelerated surge test machine, and failure rates in the low ppm are more likely with the end customer.

A commonly held misconception is that the leakage current of a Tantalum capacitor can predict the number of failures which will be seen on a surge screen. This can be disproved by the results of an experiment carried out at AVX on 47μF

Technical Summary and Application Guidelines

10V surface mount capacitors with different leakage currents. The results are summarized in the table below.

Leakage current vs number of surge failures.

Again, it must be remembered that these results were derived from a highly accelerated surge test machine, and failure rates in the low ppm are more likely with the end customer.

| | Number tested | Number failed surge |
|---|---------------|---------------------|
| Standard leakage range 0.1 μA to 1μA | 10,000 | 25 |
| Over Catalog limit 5μA to 50μA | 10,000 | 26 |
| Classified Short Circuit 50μA to 500μA | 10,000 | 25 |

OxiCap® capacitor is less sensitive to an overloading stress compared to Tantalum and so a 20% minimum derating is recommended. It may be necessary in extreme low impedance circuits of high transient or ‘switch-on’ currents to derate the voltage further. Hence in general a lower voltage OxiCap® part number can be placed on a higher rail voltage compared to the tantalum capacitor – see table below.

AVX recommended derating table.

| Voltage Rail (V) | Rated Voltage of Cap (V) | |
|------------------|--------------------------|---------|
| | Tantalum | OxiCap® |
| 3.3 | 6.3 | 4 |
| 5 | 10 | 6.3 |
| 8 | 16 | 10 |
| 10 | 20 | – |
| 12 | 25 | – |
| 15 | 35 | – |
| >24 | Series Combination | – |

For further details on surge in Tantalum capacitors refer to J.A. Gill’s paper “Surge in Solid Tantalum Capacitors”, available from AVX offices worldwide.

An added bonus of increasing the derating applied in a circuit, to improve the ability of the capacitor to withstand surge conditions, is that the steady-state reliability is improved by up to an order. Consider the example of a 6.3 volt capacitor being used on a 5 volt rail.

The steady-state reliability of a Tantalum capacitor is affected by three parameters; temperature, series resistance and voltage derating. Assume 40°C operation and 0.1 Ohms/Volt series resistance.

The capacitors reliability will therefore be:

$$\begin{aligned}
 \text{Failure rate} &= F_U \times F_T \times F_R \times 1\%/1000 \text{ hours} \\
 &= 0.15 \times 0.1 \times 1 \times 1\%/1000 \text{ hours} \\
 &= 0.015\%/1000 \text{ hours}
 \end{aligned}$$

If a 10 volt capacitor was used instead, the new scaling factor would be 0.006, thus the steady-state reliability would be:

$$\begin{aligned}
 \text{Failure rate} &= F_U \times F_T \times F_R \times 1\%/1000 \text{ hours} \\
 &= 0.006 \times 0.1 \times 1 \times 1\%/1000 \text{ hours} \\
 &= 6 \times 10^{-4} \%/1000 \text{ hours}
 \end{aligned}$$

So there is an order improvement in the capacitors steady-state reliability.

Technical Summary and Application Guidelines



SECTION 4 RECOMMENDED SOLDERING CONDITIONS

Both Tantalum and OxiCap® are lead-free system compatible components, meeting requirements of J-STD-020 standard. The maximum conditions with care: Max. Peak Temperature: 260°C for maximum 10s, 3 reflow cycles. 2 cycles are allowed for F-series capacitors.

Small parametric shifts may be noted immediately after reflow, components should be allowed to stabilize at room temperature prior to electrical testing.

RECOMMENDED REFLOW PROFILE

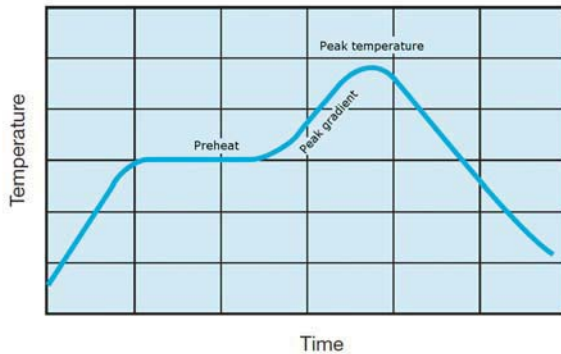

Lead-free soldering:

Pre-heating: 150±15°C/60–120sec.
Max. Peak Temperature: 245±5°C
Max. Peak Temperature Gradient: 2.5°C/sec.
Max. Time above 230°C: 40sec. max.

SnPb soldering:

Pre-heating: 150±15°C/60–90sec.
Max. Peak Temperature: 220±5°C
Max. Peak Temperature Gradient: 2°C/sec.
Max. Time above solder melting point: 60sec.

RECOMMENDED WAVE SOLDERING

Lead-free soldering:

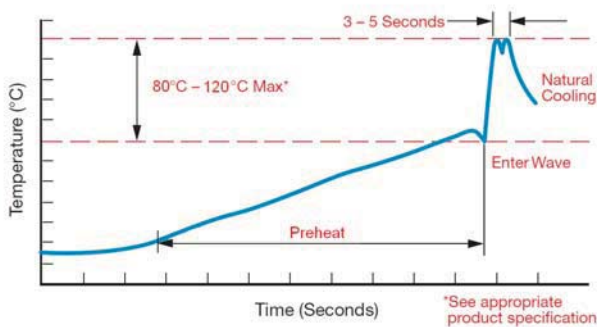

Pre-heating: 50-165°C/90-120sec.
Max. Peak Temperature: 250-260°C
Time of wave: 3-5sec.(max. 10sec.)

SnPb soldering:

Pre-heating: 50-165°C/90–120sec.
Max. Peak Temperature: 240-250°C
Time of wave: 3-5sec.(max.10sec.)

The upper side temperature of the board should not exceed +150°C.

GENERAL LEAD-FREE NOTES

The following should be noted by customers changing from lead based systems to the new lead free pastes.

- The visual standards used for evaluation of solder joints will need to be modified as lead-free joints are not as bright as with tin-lead pastes and the fillet may not be as large.
- Resin color may darken slightly due to the increase in temperature required for the new pastes.
- Lead-free solder pastes do not allow the same self alignment as lead containing systems. Standard mounting pads are acceptable, but machine set up may need to be modified.

Note: TLN, TCN and F98 series are not dedicated to wave soldering.

RECOMMENDED HAND SOLDERING

Recommended hand soldering condition:

| Tip Diameter | Selected to fit Application |
|------------------------|-----------------------------|
| Max. Tip Temperature | +370°C |
| Max. Exposure Time | 3s |
| Anti-static Protection | Non required |

Note: TLN and TCN series are not dedicated to hand soldering.



SECTION 5 TERMINATIONS

5.1 Basic Materials

Two basic materials are used for termination leads: Nilo 42 (Fe58Ni42) and copper. Copper lead frame is mainly used for products requiring low ESR performance, while Nilo 42 is used for other products. The actual status of basic material per individual part type can be checked with AVX.

5.2 Termination Finishes – Coatings

Three terminations plating are available. Standard plating material is pure matte tin (Sn). Gold or tin-lead (SnPb) are available upon request with different part number suffix designations.*

5.2.1. Pure matte tin is used as the standard coating material meeting lead-free and RoHS requirements. AVX carefully monitors the latest findings on prevention of whisker formation. Currently used techniques include use of matte tin electrodeposition, nickel barrier underplating and recrystallization of surface by reflow. Terminations are tested for whiskers according to NEMI recommendations and JEDEC standard requirements. Data is available upon request.

5.2.2. Gold Plating is available as a special option* mainly for hybrid assembly using conductive glue.

5.2.3. Tin-lead (90%Sn 10%Pb) electroplated termination finish is available as a special option* upon request.

* Some plating options can be limited to specific part types. Please check availability of special options with AVX.

Technical Summary and Application Guidelines



SECTION 6 MECHANICAL AND THERMAL PROPERTIES OF CAPACITORS

6.1 Acceleration

98.1m/s² (10g)

6.2 Vibration Severity

10 to 2000Hz, 0.75mm of 98.1m/s² (10g)

6.3 Shock

Trapezoidal Pulse, 98.1m/s² for 6ms.

6.4 Adhesion to Substrate

IEC 384-3. minimum of 5N.

6.5 Resistance to Substrate Bending

The component has compliant leads which reduces the risk of stress on the capacitor due to substrate bending.

6.6 Soldering Conditions

Dip soldering is permissible provided the solder bath temperature is $\leq 270^{\circ}\text{C}$, the solder time < 3 seconds and the circuit board thickness $\geq 1.0\text{mm}$.

6.7 Installation Instructions

The upper temperature limit (maximum capacitor surface temperature) must not be exceeded even under the most unfavorable conditions when the capacitor is installed. This must be considered particularly when it is positioned near components which radiate heat strongly (e.g. valves and power transistors). Furthermore, care must be taken, when bending the wires, that the bending forces do not strain the capacitor housing.

6.8 Installation Position

No restriction.

6.9 Soldering Instructions

Fluxes containing acids must not be used.

6.9.1 Guidelines for Surface Mount Footprints

Component footprint and reflow pad design for AVX capacitors.

The component footprint is defined as the maximum board area taken up by the terminators. The footprint dimensions are given by A, B, C and D in the diagram, which corresponds to W, max., A max., S min. and L max. for the component. The footprint is symmetric about the center lines.

The dimensions x, y and z should be kept to a minimum to reduce rotational tendencies while allowing for visual inspection of the component and its solder fillet.

Dimensions PS (c for F-series) (Pad Separation) and PW (a for F-series) (Pad Width) are calculated using dimensions x and z. Dimension y may vary, depending on whether reflow or wave soldering is to be performed.

For reflow soldering, dimensions PL (b for positive terminal of F-series; b' for negative terminal of F-series) (Pad Length), PW (a) (Pad Width), and PSL (Pad Set Length) have been calculated. For wave soldering the pad width (PWw) is reduced to less than the termination width to minimize the amount of solder pick up while ensuring that a good joint can be produced. In the case of mounting conformal coated capacitors, excentering (Δc) is needed to except anode tab [△].

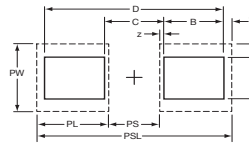

NOTE: These recommendations (also in compliance with EIA) are guidelines only. With care and control, smaller footprints may be considered for reflow soldering.

Nominal footprint and pad dimensions for each case size are given in the following tables:

PAD DIMENSIONS: millimeters (inches)

| Case Size | PSL | PL | PS | PW | PWw | |
|---|--------------------|----------------|--------------|--------------|---------------|--------------|
| SMD 'J' Lead & OxiCap® (excluding F-series) | A 4.00 (0.157) | 1.40 (0.054) | 1.20 (0.047) | 1.80 (0.071) | 0.90 (0.035) | |
| | B 4.00 (0.157) | 1.40 (0.054) | 1.20 (0.047) | 2.80 (0.110) | 1.60 (0.063) | |
| | C 6.50 (0.256) | 2.00 (0.079) | 2.50 (0.098) | 2.80 (0.110) | 1.60 (0.063) | |
| | D 8.00 (0.315) | 2.00 (0.079) | 4.00 (0.157) | 3.00 (0.119) | 1.70 (0.068) | |
| | E 8.00 (0.315) | 2.00 (0.079) | 4.00 (0.157) | 3.00 (0.119) | 1.70 (0.068) | |
| | F 6.50 (0.256) | 2.00 (0.079) | 2.50 (0.098) | 2.80 (0.110) | 1.60 (0.063) | |
| | G 4.00 (0.157) | 1.40 (0.054) | 1.20 (0.047) | 1.80 (0.071) | 0.90 (0.035) | |
| | H 4.00 (0.157) | 1.40 (0.054) | 1.20 (0.047) | 2.80 (0.110) | 1.60 (0.063) | |
| | K 4.00 (0.157) | 1.40 (0.054) | 1.20 (0.047) | 1.80 (0.071) | 0.90 (0.035) | |
| | L 4.00 (0.157) | 1.40 (0.054) | 1.20 (0.047) | 2.80 (0.110) | 1.60 (0.063) | |
| | N 2.70 (0.100) | 0.95 (0.037) | 0.80 (0.030) | 1.60 (0.060) | 0.80 (0.030) | |
| | P 2.70 (0.100) | 0.95 (0.037) | 0.80 (0.030) | 1.60 (0.060) | 0.80 (0.030) | |
| | R 2.70 (0.100) | 0.95 (0.037) | 0.80 (0.030) | 1.60 (0.060) | 0.80 (0.030) | |
| | S 4.00 (0.157) | 1.40 (0.054) | 1.20 (0.047) | 1.80 (0.071) | 0.90 (0.035) | |
| | T 4.00 (0.157) | 1.40 (0.054) | 1.20 (0.047) | 2.80 (0.110) | 1.60 (0.063) | |
| | U 8.00 (0.315) | 2.00 (0.079) | 4.00 (0.157) | 3.70 (0.145) | 1.80 (0.071) | |
| | V 8.00 (0.315) | 2.00 (0.079) | 4.00 (0.157) | 3.70 (0.145) | 1.80 (0.071) | |
| | W 6.50 (0.256) | 2.00 (0.079) | 2.50 (0.098) | 2.80 (0.110) | 1.60 (0.063) | |
| | TLN & TCN Undertab | X 8.00 (0.315) | 2.00 (0.079) | 4.00 (0.157) | 3.00 (0.119) | 1.70 (0.068) |
| | | Y 8.00 (0.315) | 2.00 (0.079) | 4.00 (0.157) | 3.00 (0.119) | 1.70 (0.068) |
| Z 8.00 (0.315) | | 2.00 (0.079) | 4.00 (0.157) | 3.70 (0.145) | 1.80 (0.071) | |
| M 3.50 (0.138) | | 1.15 (0.045) | 1.20 (0.047) | 2.40 (0.094) | N/A | |
| L 2.30 (0.091) | | 0.90 (0.035) | 0.50 (0.020) | 1.10 (0.043) | N/A | |
| N 2.00 (0.079) | | 0.70 (0.028) | 0.60 (0.024) | 1.10 (0.043) | N/A | |
| S 3.50 (0.138) | | 1.15 (0.045) | 1.20 (0.047) | 1.20 (0.047) | N/A | |
| T 3.50 (0.138) | | 1.15 (0.045) | 1.20 (0.047) | 2.40 (0.094) | N/A | |
| Y 7.20 (0.283) | | 1.50 (0.059) | 4.20 (0.165) | 2.50 (0.098) | N/A | |
| 4 7.40 (0.291) | | 2.20 (0.087) | 3.00 (0.118) | 4.80 (0.190) | N/A | |
| TACMicro-chip® | 6 15.20 (0.598) | 3.00 (0.120) | 9.20 (0.360) | 5.50 (0.217) | N/A | |
| | A 4.40 (0.173) | 1.60 (0.063) | 1.20 (0.047) | 1.80 (0.071) | 0.90 (0.035) | |
| | B 4.70 (0.185) | 1.70 (0.070) | 1.30 (0.051) | 3.00 (0.118) | 1.50 (0.059) | |
| | C 4.40 (0.173) | 1.60 (0.063) | 1.20 (0.047) | 1.80 (0.071) | 0.90 (0.035) | |
| | H 3.20 (0.126) | 1.30 (0.051) | 0.60 (0.024) | 1.50 (0.059) | 0.075 (0.375) | |
| | J 2.80 (0.110) | 1.10 (0.043) | 0.60 (0.024) | 1.00 (0.039) | 0.50 (0.020) | |
| | K 2.20 (0.087) | 0.90 (0.035) | 0.40 (0.016) | 0.70 (0.028) | 0.35 (0.014) | |
| | L 2.80 (0.110) | 1.10 (0.043) | 0.60 (0.024) | 1.00 (0.039) | 0.50 (0.020) | |
| | M 3.20 (0.126) | 1.30 (0.051) | 0.60 (0.024) | 1.00 (0.039) | 0.50 (0.020) | |
| | Q 3.20 (0.126) | 1.30 (0.051) | 0.60 (0.024) | 1.50 (0.059) | 0.075 (0.375) | |
| | R 3.20 (0.126) | 1.30 (0.051) | 0.60 (0.024) | 1.50 (0.059) | 0.075 (0.375) | |
| | S 4.40 (0.173) | 1.60 (0.063) | 1.20 (0.047) | 1.80 (0.071) | 0.90 (0.035) | |
| | T 4.70 (0.185) | 1.70 (0.070) | 1.30 (0.051) | 3.00 (0.118) | 1.50 (0.059) | |
| | U 3.20 (0.126) | 1.30 (0.051) | 0.60 (0.024) | 1.50 (0.059) | 0.075 (0.375) | |
| V 4.40 (0.173) | 1.60 (0.063) | 1.20 (0.047) | 1.80 (0.071) | 0.90 (0.035) | | |
| Z 2.80 (0.110) | 1.10 (0.043) | 0.60 (0.024) | 0.70 (0.028) | 0.35 (0.014) | | |

Note: SMD 'J' Lead = TAJ, TPS, TPM, TRJ, TRM, THJ, TAW, TLJ, TCJ, TCM

PAD DIMENSIONS F-SERIES: millimeters (inches)

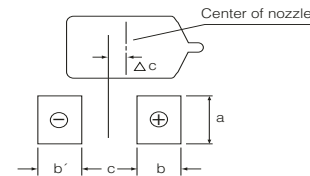

| Case Size | a | b | b' | c | Δc^* |
|------------------------------|------------------|--------------|--------------|--------------|---------------|
| F38, F91, F92, F93, F97, F98 | M 0.35 (0.014) | 0.40 (0.016) | 0.40 (0.016) | 0.40 (0.016) | 0.00 |
| | U 0.65 (0.026) | 0.70 (0.028) | 0.70 (0.030) | 0.60 (0.024) | 0.00 |
| | S 0.90 (0.035) | 0.70 (0.028) | 0.70 (0.030) | 0.80 (0.032) | 0.00 |
| | P 1.00 (0.039) | 1.10 (0.043) | 1.10 (0.043) | 0.40 (0.016) | 0.00 |
| | A 1.30 (0.051) | 1.40 (0.060) | 1.40 (0.055) | 1.00 (0.039) | 0.00 |
| | B 2.30 (0.091) | 1.40 (0.060) | 1.40 (0.055) | 1.30 (0.051) | 0.00 |
| | C 2.30 (0.091) | 2.00 (0.079) | 2.00 (0.079) | 2.70 (0.106) | 0.00 |
| | N 2.30 (0.091) | 2.00 (0.079) | 2.00 (0.079) | 4.00 (0.158) | 0.00 |
| F95, AUDIO F95 Conformal | R-P 1.40 (0.055) | 0.60 (0.024) | 0.50 (0.020) | 0.70 (0.028) | +0.20 (0.008) |
| | Q-S 1.70 (0.067) | 0.70 (0.028) | 0.60 (0.024) | 1.10 (0.043) | +0.20 (0.008) |
| | A 1.80 (0.071) | 0.70 (0.028) | 0.60 (0.024) | 1.10 (0.043) | +0.20 (0.008) |
| | T 2.60 (0.102) | 0.70 (0.028) | 0.60 (0.024) | 1.20 (0.047) | +0.20 (0.008) |
| F72 Conformal | B 2.60 (0.102) | 0.80 (0.032) | 0.70 (0.030) | 1.10 (0.043) | +0.20 (0.008) |
| | R-M 5.80 (0.228) | 1.20 (0.047) | 1.20 (0.047) | 3.90 (0.154) | 0.50 (0.020) |
| F75 Conformal | U-C 3.00 (0.118) | 1.20 (0.047) | 1.20 (0.047) | 3.30 (0.130) | 0.50 (0.020) |
| | D 4.10 (0.161) | 1.20 (0.047) | 1.20 (0.047) | 3.90 (0.154) | 0.50 (0.020) |
| | R 5.80 (0.228) | 1.20 (0.047) | 1.20 (0.047) | 3.90 (0.154) | 0.50 (0.020) |

*In the case of mounting conformal coated capacitors, excentering (Δc) is needed to except anode tab [△].



Technical Summary and Application Guidelines



6.10 PCB Cleaning

Ta chip capacitors are compatible with most PCB board cleaning systems.

If aqueous cleaning is performed, parts must be allowed to dry prior to test. In the event ultrasonics are used power levels should be less than 10 watts per/litre, and care must be taken to avoid vibrational nodes in the cleaning bath.

SECTION 7: EPOXY FLAMMABILITY

| EPOXY | UL RATING | OXYGEN INDEX |
|---|-----------|--------------|
| TAJ/TPS/TPM/TRJ/TRM/THJ TAW/TLJ/TLN/TCJ/TCM/TCN NLJ/NOJ/NOS/NOM | UL94 V-0 | 35% |

SECTION 8: QUALIFICATION APPROVAL STATUS

| DESCRIPTION | STYLE | SPECIFICATION |
|--------------------------|-------|--|
| Surface mount capacitors | TAJ | CECC 30801 - 005 Issue 2 CECC 30801 - 011 Issue 1 |

Material Data and Handling

This should be read in conjunction with the Product Datasheet. Failure to observe the ratings and the information on this sheet may result in a safety hazard.

1. Material Content

Solid Tantalum and OxiCap® capacitors do not contain liquid hazardous materials.

The operating section contains:

| | |
|------------------------|--------------------------|
| Tantalum/Niobium | Graphite/carbon |
| Tantalum/Niobium oxide | Conducting paint/resins |
| Manganese dioxide | Fluoropolymers (not TAC) |

The encapsulation contains:

TAC - epoxy molding compound, solder/tin coated terminal pads

TAJ, TPS, TPM, TRJ, TRM, TAW, TLJ, TLN, TCJ, TCM, TCN, NLJ, NOJ, NOS and NOM - epoxy molding compound, tin/solder coated terminal pads

THJ - may contain Antimony trioxide and Bromide compounds as fire retardants.

TAP - solder, solder coated terminal wires, epoxy dipped resin

The capacitors do not contain PBB or PBBO/PBBE. The solder alloys may contain lead.

2. Physical Form

These capacitors are physically small and are either rectangular with solderable terminal pads, or cylindrical or bead shaped with solderable terminal wires.

3. Intrinsic Properties

Operating

Both Tantalum and OxiCap® capacitors are polarized devices and operate satisfactorily in the correct d.c. mode. They will withstand a limited application of reverse voltage as stated in the datasheets. However, a reverse application of the rated voltage will result in early short circuit failure and may result in fire or explosion. Consequential failure of other associated components in the circuit e.g. diodes, transformers, etc. may also occur. When operated in the correct polarity, a long period of satisfactory operation will be obtained but failure may occur for any of the following reasons:

- normal failure rate
- surge voltage exceeded
- reverse voltage exceeded
- temperature too high
- ripple rating exceeded

If this failure mode is a short circuit, the previous conditions apply. If the adjacent circuit impedance is low, voltage or current surges may exceed the power handling capability of the capacitor. For this reason capacitors in circuits of below 1Ω/V should be derated by minimum 50% for tantalum and 20% for OxiCap®. Precautions should be taken to prevent reverse voltage spikes. Where capacitors may be subjected to fast switched, low impedance source voltages, the manufacturers advice should be sought to determine the most suitable capacitors for such applications.

Non-operating

Both Tantalum and OxiCap® capacitors contain no liquids or noxious gases to leak out. However, cracking or damage to the encapsulation may lead to premature failure due to ingress of material such as cleaning fluids or to stresses transmitted to the tantalum anode.

4. Fire Characteristics

Primary

Any component subject to abnormal power dissipation may

- self ignite
- become red hot
- break open or explode emitting flaming or red hot material, solid, molten or gaseous.

Fumes from burning components will vary in composition depending on the temperature, and should be considered to be hazardous, although fumes from a single component in a well ventilated area are unlikely to cause problems.

Secondary

Induced ignition may occur from an adjacent burning or red hot component. Epoxy resins used in the manufacture of capacitors give off noxious fumes when burning as stated above. Wherever possible, capacitors comply with the following:

- BS EN 60065
- UL 492.60A/280
- LOI (ASTM D2863-70) as stated in the datasheets.

5. Storage

AVX Tantalum dielectric chip capacitors are unaffected by the following storage condition for 2 years:

- Temperature: -10°C – +50°C
- Humidity: 75% RH maximum
- Atmospheric pressure: 860 mbar ~ 1060mbar

Tantalum and OxiCap® capacitors exhibit a very low random failure rate after long periods of storage and apart from this there are no known modes of failure under normal storage conditions. All capacitors will withstand any environmental conditions within their ratings for the periods given in the detail specifications. Storage for longer periods under high humidity conditions may affect the leakage current of resin protected capacitors. Solderability of solder coated surfaces may be affected by storage of excess of 2 years. If F-series capacitors should be stored more than 1 year please contact AVX for advice.

6. Moisture Sensitivity Level

MSL is defined in J-STD-020. It is applicable to non-hermetic surface mount devices, and is focussed on parts in plastic packages.

The basic concept is that a plastic package may contain moisture, which can become a high pressure vapour during solder reflow. If this occurs, the vapor pressure may cause internal cracking or damage to the device. It can also result in external steam jets from the package, and these may displace other nearby components on the circuit board during the solder process. A common industry reference for this is "popcorning".

AVX solid tantalum and OxiCap® chips which are considered MSL 1 are molded in plastic packages, and are packaged in standard packaging, not including a moisture barrier unless dry pack MSL 3 special option is used (special character V in part number).

AVX solid tantalum and OxiCap® chips which are considered MSL 3 are molded in plastic packages, and are distributed in packaging including a moisture barrier.

Material Data and Handling

AVX solid tantalum TACmicrochips® (TAC, TPC) are considered MSL 1 and supplied in packaging with a moisture barrier. TLC series is considered MSL 3 and is distributed in packaging including a moisture barrier.

7. Disposal

Incineration of epoxy coated capacitors will cause emission of noxious fumes and metal cased capacitors may explode due to build up of internal gas pressure. Disposal by any other means normally involves no special hazards. Large quantities may have salvage value.

8. Unsafe Use

Most failures are of a passive nature and do not represent a safety hazard. A hazard may, however, arise if this failure causes a dangerous malfunction of the equipment in which the capacitor is employed. Circuits should be designed to fail safe under the normal modes of failure. The usual failure mode is an increase in leakage current or short circuit. Other possible modes are decrease of capacitance, increase in dissipation factor (and impedance) or an open-circuit. Operations outside the ratings quoted in the datasheets represents unsafe use.

9. Handling

Careless handling of the cut terminal leads could result in scratches and/or skin punctures. Hands should be washed after handling solder coated terminals before eating or smoking, to avoid ingestion of lead. Capacitors must be kept out of the reach of small children. Care must be taken to discharge capacitors before handling as capacitors may retain a residual charge even after equipment in which they are being used has been switched off. Sparks from the discharge could ignite a flammable vapor.

Environmental Information

AVX has always sought to minimize the environmental impact of its manufacturing operations and of its capacitors supplied to customers throughout the world. We have a policy of preventing and minimizing waste streams during manufacture, and recycling materials wherever possible. We actively avoid or minimize environmentally hazardous materials in our production processes.

1. Material Content

For customers wishing to assess the environmental impact of AVX's capacitors contained in waste electrical and electronic equipment, the following information is provided:

Surface mount tantalum capacitors contain:

- Tantalum/Niobium and Tantalum/Niobium oxide
- Manganese dioxide
- Carbon/graphite
- Silver
- Tin/Tin-lead alloy plating
- Nickel-iron alloy or Copper alloy depending on design (consult factory for details)
- Polymers including fluorinated polymers
- Epoxide resin encapsulant

The encapsulant is made fire retardant to UL 94 V-0 by the inclusion of inert mineral filler and fire retardants.

2. Packaging Material

The component packing tape is recyclable Polycarbonate and the sealing tape is a laminate of halogen-free polymers. The reels are recyclable polystyrene, and marked with the recycling symbol. The reels are over-packed in recyclable fiber board boxes. None of the packing contains heavy metals.

3. Lead (Pb)

Parts supplied today are electroplated over the terminal contact area with 100% fused matte Tin (Sn). Parts with SnPb termination finish are available upon request only. Contact AVX for availability of parts with SnPb termination finish.

4. Fire Retardants

A combustible encapsulant free of antimony trioxide and organic bromide compound are supplied today. AVX believes that the health and safety benefits of using these materials to provide fire retardancy during the life of the product, far outweigh the possible risks to the environment and human health.

5. Nickel Alloy

It is intended that all case sizes will be made with a high copper alloy termination. Some case sizes are supplied now with this termination, and other sizes may be available. Please contact AVX if you prefer this.

6. Recycling

Surface mount Tantalum and OxiCap® capacitors have a very long service life with no known wear-out mechanism, and a low failure rate. However, parts contained in equipment which is of no further use will have some residual value mainly because of the Tantalum metal or niobium oxide contained. This can be recovered and recycled by specialist companies. The silver and nickel or copper alloy will also have some value. Please contact AVX if you require assistance with the disposal of parts. Packaging can be recycled as described above.

7. Disposal

Surface mount Tantalum and OxiCap® capacitors do not contain any liquids and no part of the devices is normally soluble in water at neutral pH values. Incineration will cause the emission of noxious fumes and is not recommended except by specialists. Landfill may be considered for disposal, bearing in mind the small lead content.

Under certain extreme physical conditions it is possible to generate ignition of Tantalum, Niobium and Niobium oxide capacitors. These physical conditions relate to high-speed impact and although not considered to be a normal operating occurrence may occur as a method of material(s) recovery. Therefore appropriate safeguards procedures and methodologies need to be adopted to eliminate any risks of material ignition.

For further information, please contact your local AVX sales office or representative.

8. Typical Weight by Case Sizes

The approximate content of some materials is given in the table below.

The specific weight of other materials contained in the various case sizes is available on written request.

| Case Size | TAJ, TPS TRJ, TLJ THJ | TPM TRM | TLN | TCJ | TCM | TCN | TAW | TMJ | NOJ NOS NLJ | NOM | TAC, TLC TPC, TMC | F38 | F72 | F75 | F91 F93 F97 | F92 | F95 | F98 | |
|---------------------|-----------------------------|------------|-----|------|-----|-----|-----|-----|-------------------|-----|----------------------|------|-----|-----|-------------------|-----|-----|-----|--|
| Typical Weight (mg) | | | | | | | | | | | | | | | | | | | |
| A | 29 | | | 28 | | | | | 25 | | 57.3 | | | | 28 | 19 | 37 | | |
| B | 68 | | | 72 | | | | | 57 | | 83.6 | | | | 65 | 36 | 68 | | |
| C | 166 | | | 137 | | | | | 154 | | | | | 240 | 160 | | 1 | | |
| D | 290 | 298 | | 346 | | | 323 | | 265 | | | | | 400 | 300 | | | | |
| E | 512 | 527 | | 472 | 474 | | | | 392 | 402 | | | | | | | | | |
| F | 148 | | | | | | | | 109 | | | | | | | | | | |
| G | 28 | | | 25 | | | | | 23 | | | | | | | | | | |
| H | 52 | | | 51 | | | | | | | 15.2 | | | | | | | | |
| J | | | | | | | | | | | 5.9 | | | | | | | | |
| K | 17 | | 22 | 15 | | | | | | | 2.8 | | | | | | | | |
| L | | | 41 | | | 38 | | | | | 9 | | | | | | | | |
| M | | | 10 | | | | | | | | 11.3 | 5.7 | 330 | | | | | 6 | |
| N | 9 | | 10 | 13 | | 10 | | | | | | | | | 350 | | | | |
| P | 15 | | | 15 | | | | | 12 | | | | | | | 9 | 18 | | |
| Q | | | | | | | | | | | | | | | | | 20 | | |
| R | 10 | | | 10 | | | | | | | 23.4 | | 180 | 670 | | | 7 | | |
| S | 19 | | 27 | 18 | | 25 | | | 17 | | | 12.4 | | | | | 25 | 13 | |
| T | 35 | | 47 | 39 | | 43 | | | 32 | | 65.8 | | | | | | 41 | | |
| U | 738 | | | | | | | 708 | | | 8.5 | | | 160 | | | | 1.6 | |
| V | 641 | 649 | | 655 | | | | 681 | 510 | | 16.4 | | | | | | | | |
| W | 99 | | | 100 | | | | | 82 | | | | | | | | | | |
| X | 152 | | | | | | | | 126 | | | | | | | | | | |
| Y | 223 | 237 | | 215 | | | | | 178 | | | | | | | | | | |
| Z | | | | | | | | | | | 3.9 | | | | | | | | |
| 4 | | | | 426 | | | | | | | | | | | | | | | |
| 6 | | | | 1056 | | | | | | | | | | | | | | | |

Environmental Information

9. RoHS Compliance

9.1 Tantalum & Niobium Oxide Capacitors (excluding F-series)

AVX can declare that we do not add any materials from the list below to series TAJ, TPS, TPM, TRJ, TRM, THJ, TAW, TLJ, TLN, TCJ, TCM, TCN, TAC, TLC, TPC, NLJ, NOJ, NOS and NOM during production, so they are not contained in any significant level.

9.2 F-Series Eco-Products “GeoCap”

AVX promotes environmentally conscious practices.

AVX offers “GeoCap”, which has completely lead free terminals and contains no polyvinyl chloride in the sleeve.

| Substances | | Taping Code | RoHS Compliance |
|-------------------------------|--------------------------------------|-------------|-----------------------------------|
| Heavy Metals | Cadmium and cadmium compounds | All | YES |
| | Lead and lead compounds | A,B,Y,P | YES |
| | | R,S,T,U | YES, since production date 1/1/04 |
| | K,H | NO | |
| Mercury and mercury compounds | All | YES | |
| | Hexavalent chromium compounds | All | YES |
| Chlorinated organic compounds | Polychlorinated biphenyls (PCB) | All | YES |
| | Polychlorinated naphthalenes (PCN) | All | YES |
| | Chlorinated paraffins (CP) | All | YES |
| | Mirex (Perchlordecone) | All | YES |
| Brominated organic compounds | Polybrominated biphenyls (PBB) | All | YES |
| | Polybrominated diphenylethers (PBDE) | All | YES |

F-SERIES TANTALUM CAPACITORS

| Type - Classification | | Series | Lead-Free Compliance | Anti Polyvinyl Chloride Compliance |
|-----------------------|-----------------------|------------------------------|----------------------|------------------------------------|
| Surface Mount type | Resin-Molded type | F38, F91, F92, F93, F97, F98 | Complied | Complied |
| | Conformal Coated type | AUDIO F95, F95, F72, F75 | | |

F-SERIES TANTALUM CAPACITORS CORRESPONDING TO RoHS DIRECTIVE

| | | Solid Tantalum Electrolytic Capacitors | | |
|---------------------------------|-------------------------------|--|---|---|
| | | Resin-Molded Chip F91, F92, F93, F97 series | Frameless Conformal Coated Chip AUDIO F95, F95, F72, F75 series | Frameless Resin-Molded Chip F38, F98 series |
| Corresponding to RoHS Directive | | Complied | Complied | Complied |
| Material | The portion of the components | Does not contain | Does not contain | Does not contain |
| | Plating on terminals | Sn | Sn-Cu | Au |
| Lead (Pb) | Structural component | Does not contain | Does not contain | Does not contain |
| | Construction of terminal | 42 Alloy/ Ni / Sn | Ni / Sn-Cu solder | Cu / Ni / Au |
| | | Plating thickness 5µm Plating type matte No heat treatment after plating | Plating thickness 30µm (Solder dipping) No heat treatment after plating | Au thickness 0.05µm Au type matte No heat treatment after plating |
| | Solderability Shear strength | No significant solderability difference between Sn-Ag-Cu and Sn-Pb solder. | No significant solderability difference between Sn-Ag-Cu and Sn-Pb solder. | No significant solderability difference between Sn-Ag-Cu and Sn-Pb solder. |
| Chromium (VI) | | Does not contain | Does not contain | Does not contain |
| Mercury | | | | |
| Cadmium | | | | |
| PBB | | | | |
| PBDE | | | | |
| MSL (IPC/JEDEC J-STD-020) | | LEVEL 1 No need dry package | ※ LEVEL 1 to LEVEL 3 If you need detailed information about MSL LEVEL, please contact your local AVX sales office. | ※ LEVEL 1 to LEVEL 3 If you need detailed information about MSL LEVEL, please contact your local AVX sales office. |

Tantalum & Niobium Oxide Capacitors

(excluding F-series)

Tape & Reel Packaging

Tape and reel packaging for automatic component placement. Please enter required Suffix on order. Bulk packaging is not available.

TAPE SPECIFICATION

Tape dimensions comply to EIA 481-1 Dimensions A₀ and B₀ of the pocket and the tape thickness, K, are dependent on the component size. Tape materials do not affect component solderability during storage. Carrier Tape Thickness <0.4mm.

TAPING SUFFIX TABLE TAJ, TPS, TPM, TRJ, TRM, THJ, TAW, TLJ, TLN TCJ, TCM, TCN, NLJ, NOJ, NOS, NOM

| Case Size | Tape width mm | P mm | 180mm (7") reel Tin Termination | | | 330mm (13") reel Tin Termination | | | 180mm (7") reel & Gold Termination | |
|-----------|---------------|------|---------------------------------|-------------------|-------|----------------------------------|-------------------|--------|------------------------------------|-------|
| | | | Suffix | Automotive Suffix | Qty. | Suffix | Automotive Suffix | Qty. | Suffix | Qty. |
| A | 8 | 4 | R | T | 2,000 | S | U | 8,000 | A | 2,000 |
| B | 8 | 4 | R | T | 2,000 | S | U | 8,000 | A | 2,000 |
| C | 12 | 8 | R | T | 500 | S | U | 3,000 | A | 500 |
| D | 12 | 8 | R | T | 500 | S | U | 2,500 | A | 500 |
| E | 12 | 8 | R | T | 400 | S | U | 1,500 | A | 400 |
| F | 12 | 8 | R | - | 1,000 | S | - | 4,000 | A | 1,000 |
| G | 8 | 4 | R | - | 2,500 | S | - | 10,000 | A | 2,500 |
| H | 8 | 4 | R | - | 2,500 | S | - | 10,000 | A | 2,500 |
| K | 8 | 4 | R | - | 3,000 | S | - | 13,000 | A | 3,000 |
| L | 8 | 4 | R | - | 2,500 | S | - | 10,000 | A | 2,500 |
| M | 8 | 4 | R | - | 3,000 | S | - | 13,000 | A | 3,000 |
| N | 8 | 4 | R | - | 3,000 | S | - | 13,000 | A | 3,000 |
| P | 8 | 4 | R | - | 2,500 | S | - | 10,000 | A | 2,500 |
| R | 8 | 4 | R | - | 2,500 | S | - | 10,000 | A | 2,500 |
| S | 8 | 4 | R | - | 2,500 | S | - | 10,000 | A | 2,500 |
| T | 8 | 4 | R | - | 2,500 | S | - | 10,000 | A | 2,500 |
| U | 16 | 8 | R | - | 400 | - | - | - | - | - |
| V | 12 | 8 | R | - | 400 | S | - | 1,500 | A | 400 |
| W | 12 | 8 | R | - | 1,000 | S | - | 5,000 | A | 1,000 |
| X | 12 | 8 | R | - | 1,000 | S | - | 5,000 | A | 1,000 |
| Y | 12 | 8 | R | - | 1,000 | S | - | 4,000 | A | 1,000 |
| Z | 16 | 8 | R | - | 400 | S | - | 1,500 | - | - |
| 4 | 16 | 8 | R | - | 800 | S | - | TBD | - | - |
| 6 | 24 | 12 | R | - | 500 | S | - | TBD | - | - |

Under Development

TAPING SUFFIX TABLE TAC AND TLC

| Case Size | Tape width mm | P mm | 100mm (4") reel Tin Termination | | 180mm (7") reel Tin Termination | | 100mm (4") reel & Gold Termination | | 180mm (7") reel & 100% Gold Termination | |
|-----------|---------------|------|---------------------------------|-------|---------------------------------|--------|------------------------------------|-------|---|--------|
| | | | Suffix | Qty. | Suffix | Qty. | Suffix | Qty. | Suffix | Qty. |
| A | 8 | 4 | XTA | 500 | RTA | 2,000 | FTA | 500 | ATA | 2,000 |
| B | 8 | 4 | XTA | 500 | RTA | 2,500 | FTA | 500 | ATA | 2,500 |
| C | 8 | 4 | XTA | 500 | RTA | 3,500 | - | - | - | - |
| H | 8 | 4 | XTA | 500 | RTA | 3,500 | FTA | 500 | ATA | 3,500 |
| J | 8 | 4 | XTA | 500 | RTA | 3,500 | FTA | 500 | ATA | 3,500 |
| K | 8 | 2 | QTA | 1,000 | PTA | 10,000 | NTA | 1,000 | MTA | 10,000 |
| L | 8 | 4 | XTA | 500 | RTA | 3,500 | FTA | 500 | ATA | 3,500 |
| M | 8 | 4 | XTA | 500 | RTA | 2,500 | FTA | 500 | ATA | 2,500 |
| N | 8 | 2 | QTA | 1,000 | PTA | 10,000 | - | - | - | - |
| Q | 8 | 4 | XTA | 500 | RTA | 2,500 | - | - | - | - |
| R | 8 | 4 | XTA | 500 | RTA | 2,500 | FTA | 500 | ATA | 2,500 |
| S | 8 | 4 | XTA | 500 | RTA | 2,500 | - | - | - | - |
| T | 8 | 4 | XTA | 500 | RTA | 2,500 | FTA | 500 | ATA | 2,500 |
| U | 8 | 4 | XTA | 500 | RTA | 3,500 | FTA | 500 | ATA | 3,500 |
| V | 8 | 4 | XTA | 500 | RTA | 2,500 | FTA | 500 | ATA | 2,500 |
| Z | 8 | 2 | QTA | 1,000 | PTA | 10,000 | - | - | - | - |

Under Development

Tantalum & Niobium Oxide Capacitors

(excluding F-series)

Tape & Reel Packaging

TAPING SUFFIX TABLE TPC

| Case Size | Tape width mm | P mm | 100mm (4") reel Tin Termination | | 180mm (7") reel Tin Termination | | 100mm (4") reel & Gold Termination | | 180mm (7") reel & 100% Gold Termination | |
|-----------|------------------|---------|------------------------------------|-------|------------------------------------|--------|---------------------------------------|-------|--|--------|
| | | | Suffix | Qty. | Suffix | Qty. | Suffix | Qty. | Suffix | Qty. |
| H | 8 | 4 | Xxxxx | 500 | Rxxxx | 3,500 | Fxxxx | 500 | Axxxx | 3,500 |
| K | 8 | 2 | Qxxxx | 1,000 | Pxxxx | 10,000 | Nxxxx | 1,000 | Mxxxx | 10,000 |
| L | 8 | 4 | Xxxxx | 500 | Rxxxx | 3,500 | Fxxxx | 500 | Axxxx | 3,500 |
| R | 8 | 4 | Xxxxx | 500 | Rxxxx | 2,500 | Fxxxx | 500 | Axxxx | 2,500 |

Note: xxxx = ESR value in Milliohms

TAPING SUFFIX TABLE TLC

| Case Size | Tape width mm | P mm | 100mm (4") reel Tin Termination | | 180mm (7") reel Tin Termination | | 100mm (4") reel & Gold Termination | | 180mm (7") reel & 100% Gold Termination | |
|-----------|------------------|---------|------------------------------------|------|------------------------------------|-------|---------------------------------------|------|--|-------|
| | | | Suffix | Qty. | Suffix | Qty. | Suffix | Qty. | Suffix | Qty. |
| L | 8 | 4 | Xxxxx | 500 | Rxxxx | 3,500 | Fxxxx | 500 | Axxxx | 3,500 |

Note: xxxx = ESR value in Milliohms

Tantalum & Niobium Oxide Capacitors

(excluding F-series)

Tape & Reel Packaging

PLASTIC TAPE DIMENSIONS TAJ, TPS, TPM, TRJ, TRM, THJ, TAW, TLJ, TLN, TCJ, TCM, TCN, NLJ, NOJ, NOS AND NOM

| Case | A0±0.10 | B0±0.10 | K±0.10 | W±0.30 | E±0.10 | F±0.05 | G min. | P±0.10 | P2±0.05 | P0±0.10 | D0 ^{+0.20} _{-0.00} | D1 ^{+0.25} _{-0.00} |
|------|---------|---------|--------|--------|--------|----------|--------|--------|----------|---------|--------------------------------------|--------------------------------------|
| A | 1.83 | 3.57 | 1.87 | 8.00 | 1.75 | 3.50 | 0.75 | 4.00 | 2.00 | 4.00 | 1.50 | 1.00 |
| B | 3.15 | 3.77 | 2.22 | 8.00 | 1.75 | 3.50 | 0.75 | 4.00 | 2.00 | 4.00 | 1.50 | 1.00 |
| C | 3.45 | 6.40 | 2.92 | 12.00 | 1.75 | 5.50 | 0.75 | 8.00 | 2.00 | 4.00 | 1.50 | 1.50 |
| D | 4.48 | 7.62 | 3.22 | 12.00 | 1.75 | 5.50 | 0.75 | 8.00 | 2.00 | 4.00 | 1.50 | 1.50 |
| E | 4.50 | 7.50 | 4.50 | 12.00 | 1.75 | 5.50 | 0.75 | 8.00 | 2.00 | 4.00 | 1.50 | 1.50 |
| F | 3.35 | 6.40 | 2.20 | 12.00 | 1.75 | 5.50 | 0.75 | 8.00 | 2.00 | 4.00 | 1.50 | 1.50 |
| G | 1.83 | 3.57 | 1.65 | 8.00 | 1.75 | 3.50 | 0.75 | 4.00 | 2.00 | 4.00 | 1.50 | 1.00 |
| H | 3.15 | 3.77 | 1.66 | 8.00 | 1.75 | 3.50 | 0.75 | 4.00 | 2.00 | 4.00 | 1.50 | 1.00 |
| K | 1.95 | 3.55 | 1.15 | 8.00 | 1.75 | 3.50 | 0.75 | 4.00 | 2.00 | 4.00 | 1.50 | 1.00 |
| L | 3.10 | 3.80 | 1.30 | 8.00 | 1.75 | 3.50 | 0.75 | 4.00 | 2.00 | 4.00 | 1.50 | 1.00 |
| M | 1.60 | 2.35 | 1.10 | 8.00 | 1.75 | 3.50 | 0.75 | 4.00 | 2.00 | 4.00 | 1.50 | 1.00 |
| N | 1.60 | 2.30 | 1.10 | 8.00 | 1.75 | 3.50 | 0.75 | 4.00 | 2.00 | 4.00 | 1.50 | 1.00 |
| P | 1.65 | 2.45 | 1.60 | 8.00 | 1.75 | 3.50 | 0.75 | 4.00 | 2.00 | 4.00 | 1.50 | 1.00 |
| R | 1.65 | 2.45 | 1.30 | 8.00 | 1.75 | 3.50 | 0.75 | 4.00 | 2.00 | 4.00 | 1.50 | 1.00 |
| S | 1.95 | 3.55 | 1.30 | 8.00 | 1.75 | 3.50 | 0.75 | 4.00 | 2.00 | 4.00 | 1.50 | 1.00 |
| T | 3.20 | 3.80 | 1.30 | 8.00 | 1.75 | 3.50 | 0.75 | 4.00 | 2.00 | 4.00 | 1.50 | 1.00 |
| U | 6.19 | 7.66 | 4.72 | 16.00 | 1.75 | 7.50 | 0.75 | 8.00 | 2.00 | 4.00 | 1.50 | 1.50 |
| V | 6.43 | 7.44 | 3.84 | 12.00 | 1.75 | 5.50 | 0.75 | 8.00 | 2.00 | 4.00 | 1.50 | 1.50 |
| W | 3.57 | 6.40 | 1.65 | 12.00 | 1.75 | 5.50 | 0.75 | 8.00 | 2.00 | 4.00 | 1.50 | 1.50 |
| X | 4.67 | 7.62 | 1.65 | 12.00 | 1.75 | 5.50 | 0.75 | 8.00 | 2.00 | 4.00 | 1.50 | 1.50 |
| Y | 4.67 | 7.62 | 2.15 | 12.00 | 1.75 | 5.50 | 0.75 | 8.00 | 2.00 | 4.00 | 1.50 | 1.50 |
| 4 | 6.25 | 7.88 | 2.25 | 16.00 | 1.75 | 7.50±0.1 | 0.75 | 8.00 | 2.00±0.1 | 4.00 | 1.50 | 1.50 |
| 6 | 8.55 | 15.60 | 2.25 | 24.00 | 1.75 | 11.50 | 0.75 | 12.00 | 2.00 | 4.00 | 1.50 | 1.50 |

PLASTIC TAPE DIMENSIONS TAC, TLC AND TPC

| Case | A0±0.10 | B0±0.10 | K±0.10 | W±0.30 | E±0.10 | F±0.05 | G min. | P±0.10 | P2±0.05 | P0±0.10 | D0 ^{+0.20} _{-0.00} | D1 ^{+0.20} _{-0.00} |
|------|--|--|--|--------|--------|--------|--------|--------|---------|---------|--------------------------------------|--------------------------------------|
| A | 1.83±0.10 | 3.57±0.10 | 1.87±0.10 | 8.00 | 1.75 | 3.50 | 0.75 | 4.00 | 2.00 | 4.00 | 1.50 | 1.00 |
| B | 3.15±0.10 | 3.77±0.10 | 1.66±0.10 | 8.00 | 1.75 | 3.50 | 0.75 | 4.00 | 2.00 | 4.00 | 1.50 | 1.00 |
| C | 1.95±0.10 | 3.55±0.10 | 1.15±0.10 | 8.00 | 1.75 | 3.50 | 0.75 | 4.00 | 2.00 | 4.00 | 1.50 | 1.00 |
| H | 1.65±0.10 | 2.45±0.10 | 1.10±0.05 | 8.00 | 1.75 | 3.50 | 0.75 | 4.00 | 2.00 | 4.00 | 1.50 | 1.00 |
| J | 1.05 ^{+0.10} _{-0.00} | 1.90 ^{+0.10} _{-0.00} | 0.80 ^{+0.10} _{-0.00} | 8.00 | 1.75 | 3.50 | 0.75 | 4.00 | 2.00 | 4.00 | 1.50 | 0.80 |
| K | 0.75 ^{+0.05} _{-0.00} | 1.26 ^{+0.10} _{-0.00} | 0.67 ^{+0.10} _{-0.00} | 8.00 | 1.75 | 3.50 | 0.75 | 2.00 | 2.00 | 2.00 | 1.50 | 0.50 |
| L | 1.05 ^{+0.10} _{-0.00} | 1.90 ^{+0.10} _{-0.00} | 1.05 ^{+0.10} _{-0.00} | 8.00 | 1.75 | 3.50 | 0.75 | 4.00 | 2.00 | 4.00 | 1.50 | 0.80 |
| M | 1.05 ^{+0.10} _{-0.00} | 2.45±0.10 | 1.05 ^{+0.10} _{-0.00} | 8.00 | 1.75 | 3.50 | 0.75 | 4.00 | 2.00 | 4.00 | 1.50 | 0.80 |
| Q | 1.65±0.10 | 2.45±0.10 | 1.30±0.10 | 8.00 | 1.75 | 3.50 | 0.75 | 4.00 | 2.00 | 4.00 | 1.50 | 1.00 |
| R | 1.65±0.10 | 2.45±0.10 | 1.60±0.10 | 8.00 | 1.75 | 3.50 | 0.75 | 4.00 | 2.00 | 4.00 | 1.50 | 1.00 |
| S | 1.95±0.10 | 3.55±0.10 | 1.30±0.10 | 8.00 | 1.75 | 3.50 | 0.75 | 4.00 | 2.00 | 4.00 | 1.50 | 1.00 |
| T | 3.20±0.10 | 3.80±0.10 | 1.30±0.10 | 8.00 | 1.75 | 3.50 | 0.75 | 4.00 | 2.00 | 4.00 | 1.50 | 1.00 |
| U | 1.65±0.10 | 2.45±0.10 | 0.80±0.05 | 8.00 | 1.75 | 3.50 | 0.75 | 4.00 | 2.00 | 4.00 | 1.50 | 1.00 |
| V | 1.95±0.10 | 3.60±0.10 | 0.90±0.10 | 8.00 | 1.75 | 3.50 | 0.75 | 4.00 | 2.00 | 4.00 | 1.50 | 1.00 |
| X | 1.83±0.10 | 3.57±0.10 | 1.87±0.10 | 8.00 | 1.75 | 3.50 | 0.75 | 4.00 | 2.00 | 4.00 | 1.50 | 1.00 |
| Z | 0.75 ^{+0.05} _{-0.00} | 1.90 ^{+0.10} _{-0.00} | 0.67 ^{+0.10} _{-0.00} | 8.00 | 1.75 | 3.50 | 0.75 | 2.00 | 2.00 | 2.00 | 1.50 | 0.50 |

Under development

Tantalum & Niobium Oxide Capacitors **AVX** (excluding F-series)

Tape & Reel Packaging

REEL DIMENSIONS

| Reel Size | Tape | A | B | C | W | t |
|---------------|------|----------|--------|-----------|-------------|-----------|
| 180mm (7") | 12mm | 178±2.00 | 50 min | 13.0±0.50 | 12.4+1.5/-0 | 1.50±0.50 |
| 180mm (7") | 8mm | 178±2.00 | 50 min | 13.0±0.50 | 8.4+1.5/-0 | 1.50±0.50 |
| 330mm (13") | 12mm | 328±2.00 | 50 min | 13.0±0.50 | 12.4+1.5/-0 | 1.50±0.50 |
| 330mm (13") | 8mm | 328±2.00 | 50 min | 13.0±0.50 | 8.4+1.5/-0 | 1.50±0.50 |
| 108mm (4.25") | 8mm | 108±2.00 | | 13.0±0.50 | 8.4+1.5/-0 | 1.50±0.50 |

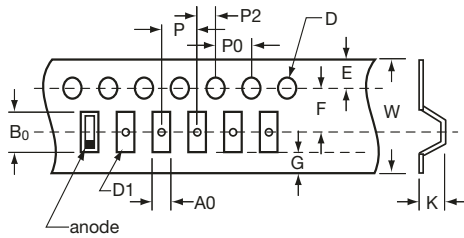
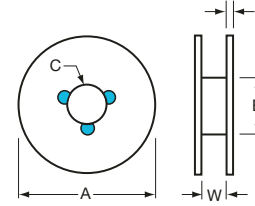

COVER TAPE NOMINAL DIMENSIONS

Thickness: 75µm
 Width of tape: 5.5mm (8mm tape)
 9.5mm (12mm tape)

F-Series Tantalum Capacitors



Tape & Reel Packaging

TAPING QUANTITY TABLE – F-SERIES CAPACITORS

| Series | Case Size | 180mm (7") Reel | 330mm (13") Reel |
|------------------|------------|----------------------|----------------------|
| | | Tin Termination Qty. | Tin Termination Qty. |
| F38, F98 | U | 10,000 | – |
| | M, S | 4,000 | – |
| F92 | P | 3,000 | 8,000 |
| | A, B | 2,500 | 8,000 |
| F91 | A | 2,000 | 8,000 |
| F93 | B | 2,000 | 6,000 |
| F97 | C, N | 500 | 2,500 |
| F95 AUDIO F95 | R, P | 3,000 | 10,000 |
| | Q, S, A, T | 2,500 | 10,000 |
| | B | 2,000 | 8,500 |
| F72 | R | 1,000 | – |
| | M | 500 | – |
| F75 | U, C, D, R | 500 | – |

(*) : Export packaging. There are some differences between actual minimum quantity and above list. Please confirm before you order.

TYPE NUMBERING SYSTEM

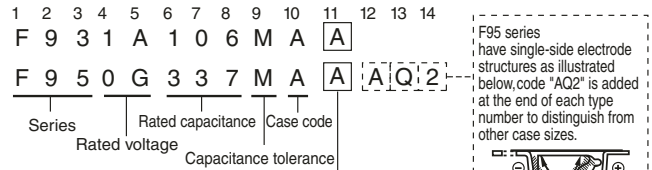

| Tape Width (mm) | Polarity | Tape | | Applicable Case Size | | |
|-----------------|--|------------------------|------------------------|-----------------------|-------------------|-------------|
| | | Reel Dia ϕ 180 mm | Reel Dia ϕ 330 mm | F91, F92 F93, F97 F98 | F95 AUDIO F95 | F72 F75 |
| 8 | R (Anode is at opposite side of feeding holes) | A | E | U, M, S P, A, B | R, P, Q S, A, T B | – |
| 12 | R (Anode is at opposite side of feeding holes) | C | G | C, N | – | U, C D, R M |

REEL DIMENSIONS (mm)

| Item | Reel Diameter | |
|------|-------------------------|--------------------|
| | 180 ϕ | 330 ϕ |
| A | ϕ 180 $^{+0}_{-3}$ | ϕ 330 \pm 2 |

| Item | Tape Width | |
|----------------|----------------|----------------|
| | 8 | 12 |
| W ₁ | 9.0 \pm 0.3 | 13 \pm 0.3 |
| W ₂ | 11.4 \pm 1.0 | 15.4 \pm 1.0 |

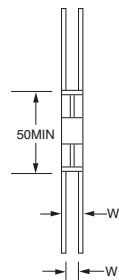
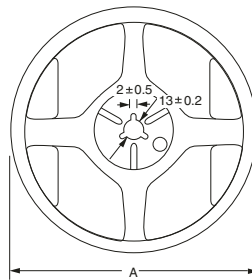

Note: The above shows the dimensions of ϕ 180 reel. In case of ϕ 330 reel, the appearance shape is slightly different.

CARRIER TAPE DIMENSIONS (mm)

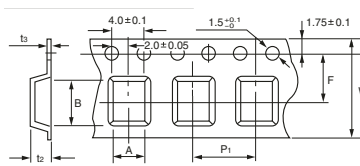

F91, F92, F93, F97, F98 M, F38 M

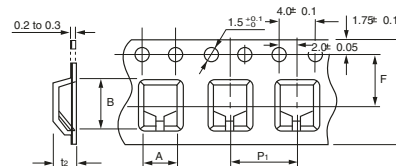

F95, AUDIO F95, F72, F75

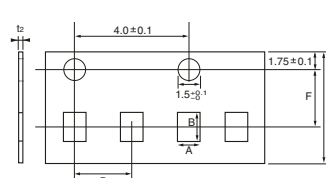

F98U

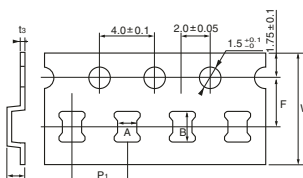

F98 S, F38 S

| Case Code | W | A | B | F | P ₁ | t ₂ | t ₃ |
|-----------|----------------|-----------------|-----------------|----------------|----------------|-----------------|-----------------|
| U | 8.0 \pm 0.3 | 0.73 \pm 0.08 | 1.20 \pm 0.05 | 3.5 \pm 0.05 | 2.0 \pm 0.1 | 0.7 Max. | – |
| M | | 0.97 \pm 0.05 | 1.85 \pm 0.05 | | | 0.95 \pm 0.05 | 0.20 \pm 0.05 |
| S | | 1.35 \pm 0.1 | 2.15 \pm 0.1 | 4.0 \pm 0.1 | | 1.4 Max. | 0.2 to 0.3 |
| P | | 1.55 \pm 0.1 | 2.3 \pm 0.1 | | | (1.7 Max.) | |
| A | 12.0 \pm 0.3 | 1.9 \pm 0.1 | 3.5 \pm 0.1 | 3.5 \pm 0.05 | 8.0 \pm 0.1 | 2.1 Max. (1.7) | |
| B | | 3.3 \pm 0.1 | 3.8 \pm 0.1 | | | 2.4 Max. (1.7) | |
| C | | 3.6 \pm 0.1 | 6.3 \pm 0.1 | 5.5 \pm 0.05 | | 5.5 \pm 0.1 | 8.0 \pm 0.1 |
| N | 4.8 \pm 0.1 | 7.7 \pm 0.1 | 3.5 Max. | | 4.6 Max. | | |

| Type | Case Code | W | A | B | F | P ₁ | t ₂ | |
|------------------|-----------|----------------|---------------|---------------|----------------|----------------|----------------|----------|
| F95 AUDIO F95 | R | 8.0 \pm 0.3 | 1.4 \pm 0.2 | 2.6 \pm 0.2 | 3.5 \pm 0.05 | 4.0 \pm 0.1 | 1.05 Max. | |
| | P | | 2.0 \pm 0.2 | 3.6 \pm 0.2 | | | 1.5 Max. | |
| | Q, S | | 2.1 \pm 0.2 | 3.7 \pm 0.2 | | | 1.5 Max. | |
| | A | | 3.0 \pm 0.2 | 3.6 \pm 0.2 | | | 2.0 Max. | |
| | T | | 3.1 \pm 0.2 | 3.7 \pm 0.2 | | | 1.5 Max. | |
| F72 | B | 12.0 \pm 0.3 | 6.5 \pm 0.2 | 7.6 \pm 0.2 | 5.5 \pm 0.1 | 8.0 \pm 0.1 | 2.4 Max. | |
| | R | | 6.5 \pm 0.2 | 7.6 \pm 0.2 | | | 2.2 Max. | |
| F75 | U | 12.0 \pm 0.3 | 3.7 \pm 0.2 | 7.6 \pm 0.2 | 5.5 \pm 0.1 | 8.0 \pm 0.1 | 2.5 Max. | |
| | C | | 4.8 \pm 0.2 | | | | 7.9 \pm 0.2 | 2.7 Max. |
| | D | | 6.5 \pm 0.2 | | | | 7.6 \pm 0.2 | 3.6 Max. |
| | R | | 6.5 \pm 0.2 | | | | 7.6 \pm 0.2 | 3.9 Max. |



Tantalum & Niobium Oxide Capacitors **AVX**

Marking

For TAJ, TPS & THJ, the positive end of body has videcon readable polarity marking as shown in the diagram. Bodies are marked by indelible laser marking on top surface with capacitance value, voltage and ID code. N, P and R case is an exception due to small size in which only the voltage and capacitance values are printed.

All series excluding F-Series capacitors

| Voltage Code | Rated Voltage at 85°C | Voltage Code | Rated Voltage at 85°C |
|--------------|-----------------------|--------------|-----------------------|
| x | 1.8 | D | 20 |
| e | 2.5 | E | 25 |
| G | 4 | V | 35 |
| J | 6.3 | T | 50 |
| P | 8 | J | 63 |
| A | 10 | P | 75 |
| B | 12 | A | 100 |
| C | 16 | B | 125 |

TAJ, TRJ, TRM, TPS, TPM – A, B, C, D, E, F, H, K, S, T, U, V, W, X AND Y CASE:

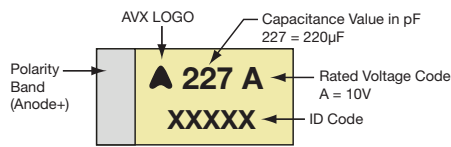

TCJ, TCM, TCN – A, B, C, D, E, G, H, K, L, S, T, V, W, Y CASE:

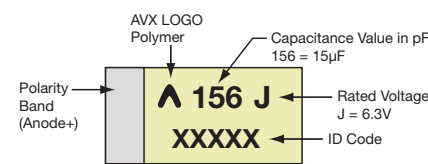

TLJ, TLN – A, B, F, G, H, K, L, S, T, V, W, Y CASE:

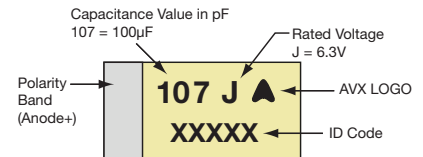

TAJ, TPS – P AND R CASE:

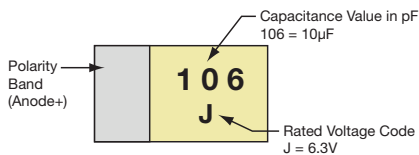

TCJ – N, P, R CASE:

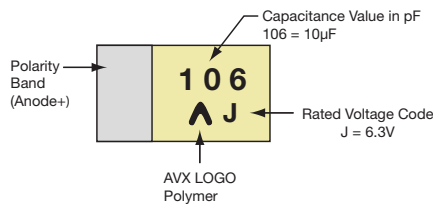

TLJ, TLN – M, N, P, R CASE:

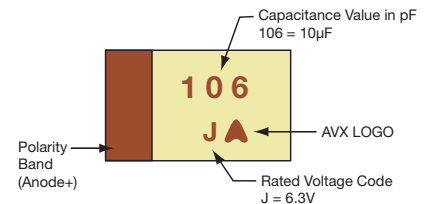

THJ – A, B, C, D, E CASE:

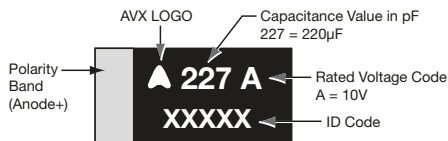

TAW – D CASE:

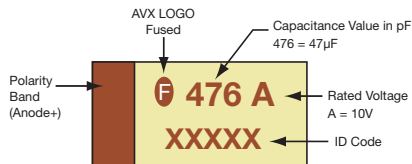

TLN PULSECAP™ 4 AND 6 CASE:

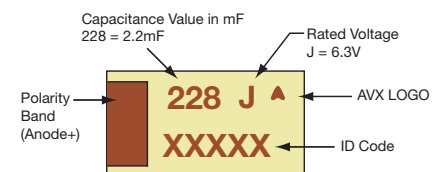

NOJ, NOS, NOM – A, B, C, D, E, F, S, T, V, W, X, Y CASE:

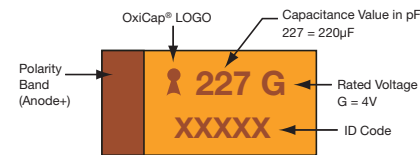

NLJ – A, B, G, P, S, T, CASE:

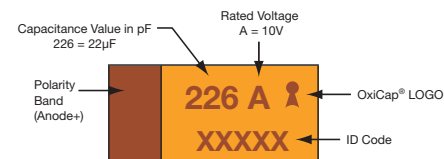

TAC, TLC, TPC – ALL CASE SIZES:

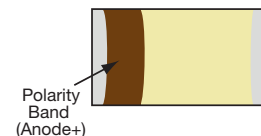

NOJ – P CASE:

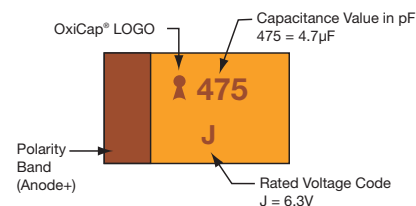

**F-SERIES CAPACITORS
PLEASE REFER TO THE CATALOGUE SHEET**

TAP/TEP Technical Summary and Application Guidelines



SECTION 1: ELECTRICAL CHARACTERISTICS AND EXPLANATION OF TERMS

1.1 CAPACITANCE

1.1.1 Rated capacitance (C_R)

This is the nominal rated capacitance. For tantalum capacitors it is measured as the capacitance of the equivalent series circuit at 20°C in a measuring bridge supplied by a 120 Hz source free of harmonics with 2.2V DC bias max.

1.1.2 Temperature dependence on the capacitance

The capacitance of a tantalum capacitor varies with temperature. This variation itself is dependent to a small extent on the rated voltage and capacitor size. See graph below for typical capacitance changes with temperature.

Typical Capacitance vs. Temperature

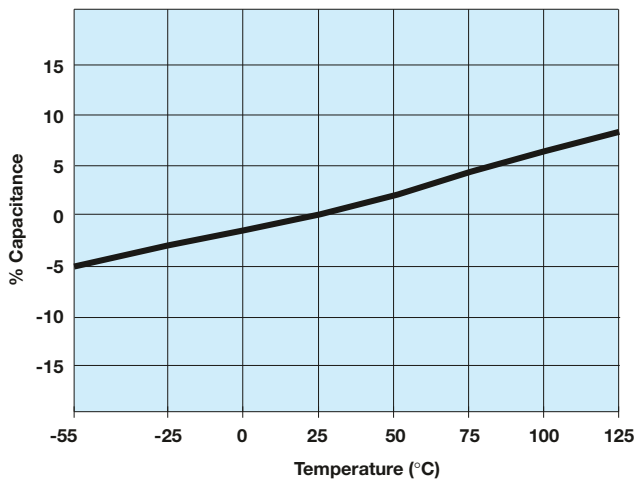

1.1.3 Capacitance tolerance

This is the permissible variation of the actual value of the capacitance from the rated value.

1.1.4 Frequency dependence of the capacitance

The effective capacitance decreases as frequency increases. Beyond 100 kHz the capacitance continues to drop until resonance is reached (typically between 0.5-5 MHz depending on the rating). Beyond this the device becomes inductive.

Typical Curve Capacitance vs. Frequency

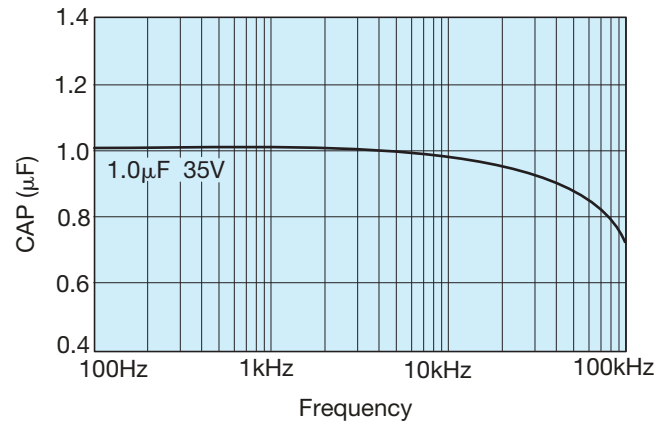

1.2 VOLTAGE

1.2.1 Rated DC voltage (V_R)

This is the rated DC voltage for continuous operation up to +85°C.

1.2.2 Category voltage (V_C)

This is the maximum voltage that may be applied continuously to a capacitor. It is equal to the rated voltage up to +85°C, beyond which it is subject to a linear derating, to 2/3 V_R at 125°C.

1.2.3 Surge voltage (V_S)

This is the highest voltage that may be applied to a capacitor for short periods of time. The surge voltage may be applied up to 10 times in an hour for periods of up to 30 seconds at a time. The surge voltage must not be used as a parameter in the design of circuits in which, in the normal course of operation, the capacitor is periodically charged and discharged.

Category Voltage vs. Temperature

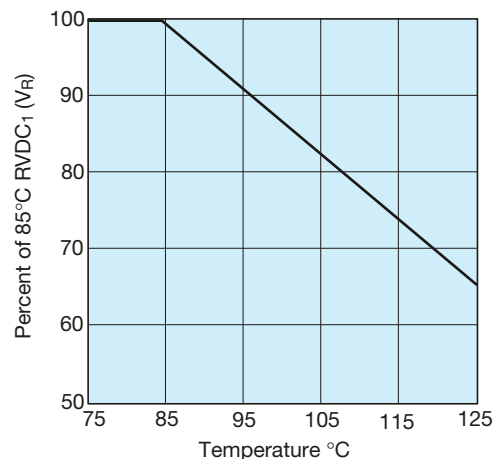

TAP/TEP Technical Summary and Application Guidelines



| 85°C | | 125°C | |
|----------------------|----------------------|-------------------------|----------------------|
| Rated Voltage (V DC) | Surge Voltage (V DC) | Category Voltage (V DC) | Surge Voltage (V DC) |
| 2 | 2.6 | 1.3 | 1.7 |
| 3 | 4 | 2 | 2.6 |
| 4 | 5.2 | 2.6 | 3.4 |
| 6.3 | 8 | 4 | 5 |
| 10 | 13 | 6.3 | 9 |
| 16 | 20 | 10 | 12 |
| 20 | 26 | 13 | 16 |
| 25 | 33 | 16 | 21 |
| 35 | 46 | 23 | 28 |
| 50 | 65 | 33 | 40 |

1.2.4 Effect of surges

The solid Tantalum capacitor has a limited ability to withstand surges (15% to 30% of rated voltage). This is in common with all other electrolytic capacitors and is due to the fact that they operate under very high electrical stress within the oxide layer. In the case of 'solid' electrolytic capacitors this is further complicated by the limited self healing ability of the manganese dioxide semiconductor.

It is important to ensure that the voltage across the terminals of the capacitor does not exceed the surge voltage rating at any time. This is particularly so in low impedance circuits where the capacitor is likely to be subjected to the full impact of surges, especially in low inductance applications. Even an extremely short duration spike is likely to cause damage. In such situations it will be necessary to use a higher voltage rating.

1.3 DISSIPATION FACTOR AND TANGENT OF LOSS ANGLE (TAN D)

1.3.1 Dissipation factor (DF)

Dissipation factor is the measurement of the tangent of the loss angle ($\tan \delta$) expressed as a percentage.

The measurement of DF is carried out at +25°C and 120 Hz with 2.2V DC bias max. with an AC voltage free of harmonics. The value of DF is temperature and frequency dependent.

1.3.2 Tangent of loss angle ($\tan \delta$)

This is a measure of the energy loss in the capacitor. It is expressed as $\tan \delta$ and is the power loss of the capacitor divided by its reactive power at a sinusoidal voltage of specified frequency. (Terms also used are power factor, loss factor and dielectric loss, $\cos(90 - \delta)$ is the true power factor.) The measurement of $\tan \delta$ is carried out at +20°C and 120 Hz with 2.2V DC bias max. with an AC voltage free of harmonics.

1.2.5 Reverse voltage and non-polar operation

The reverse voltage ratings are designed to cover exceptional conditions of small level excursions into incorrect polarity. The values quoted are not intended to cover continuous reverse operation.

The peak reverse voltage applied to the capacitor must not exceed:

- 10% of rated DC working voltage to a maximum of 1V at 25°C

- 3% of rated DC working voltage to a maximum of 0.5V at 85°C

- 1% of category DC working voltage to a maximum of 0.1V at 125°C

1.2.6 Non-polar operation

If the higher reverse voltages are essential, then two capacitors, each of twice the required capacitance and of equal tolerance and rated voltage, should be connected in a back-to-back configuration, i.e., both anodes or both cathodes joined together. This is necessary in order to avoid a reduction in life expectancy.

1.2.7 Superimposed AC voltage (V_{rms}) - Ripple Voltage

This is the maximum RMS alternating voltage, superimposed on a DC voltage, that may be applied to a capacitor. The sum of the DC voltage and the surge value of the superimposed AC voltage must not exceed the category voltage, V_C . Full details are given in Section 2.

1.2.8 Voltage derating

Refer to section 3.2 (pages 157-159) for the effect of voltage derating on reliability.

1.3.3 Frequency dependence of dissipation factor

Dissipation Factor increases with frequency as shown in the typical curves below.

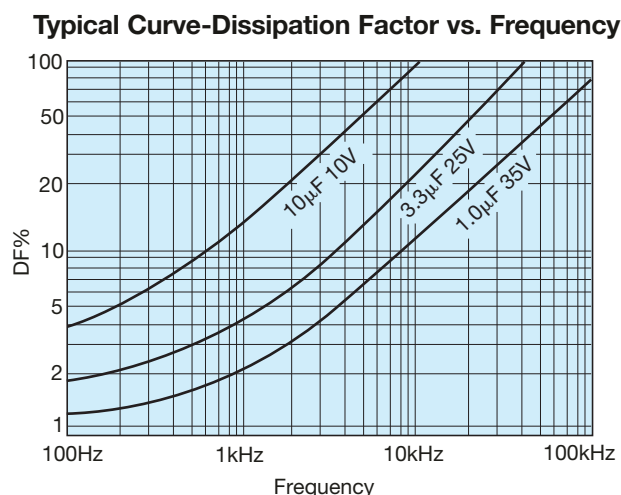

TAP/TEP Technical Summary and Application Guidelines



1.3.4 Temperature dependence of dissipation factor

Dissipation factor varies with temperature as the typical curves show to the right. For maximum limits please refer to ratings tables.

Typical Curves-Dissipation Factor vs. Temperature

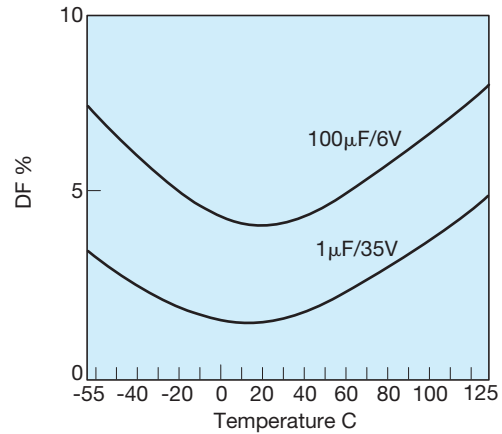

1.4 IMPEDANCE, (Z) AND EQUIVALENT SERIES RESISTANCE (ESR)

1.4.1 Impedance, Z

This is the ratio of voltage to current at a specified frequency. Three factors contribute to the impedance of a tantalum capacitor; the resistance of the semiconducting layer, the capacitance, and the inductance of the electrodes and leads.

At high frequencies the inductance of the leads becomes a limiting factor. The temperature and frequency behavior of these three factors of impedance determine the behavior of the impedance Z. The impedance is measured at 25°C and 100 kHz.

1.4.2 Equivalent series resistance, ESR

Resistance losses occur in all practical forms of capacitors. These are made up from several different mechanisms, including resistance in components and contacts, viscous forces within the dielectric, and defects producing bypass current paths. To express the effect of these losses they are considered as the ESR of the capacitor. The ESR is frequency dependent. The ESR can be found by using the relationship:

$$ESR = \frac{\tan \delta}{2\pi f C}$$

where f is the frequency in Hz, and C is the capacitance in farads. The ESR is measured at 25°C and 100 kHz.

ESR is one of the contributing factors to impedance, and at high frequencies (100 kHz and above) is the dominant factor, so that ESR and impedance become almost identical, impedance being marginally higher.

1.4.3 Frequency dependence of impedance and ESR

ESR and impedance both increase with decreasing frequency. At lower frequencies the values diverge as the extra contributions to impedance (resistance of the semiconducting layer, etc.) become more significant. Beyond 1 MHz (and beyond the resonant point of the capacitor) impedance again increases due to induction.

Frequency Dependence of Impedance and ESR

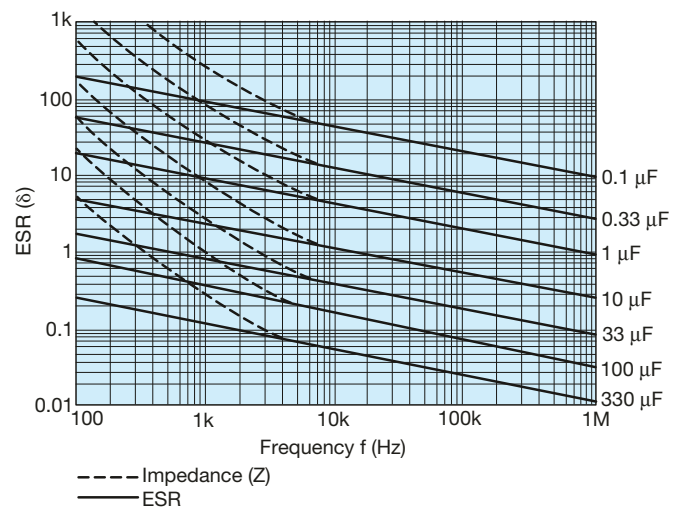

TAP/TEP Technical Summary and Application Guidelines



1.4.4 Temperature dependence of the impedance and ESR

At 100 kHz, impedance and ESR behave identically and decrease with increasing temperature as the typical curves show. For maximum limits at high and low temperatures, please refer to graph opposite.

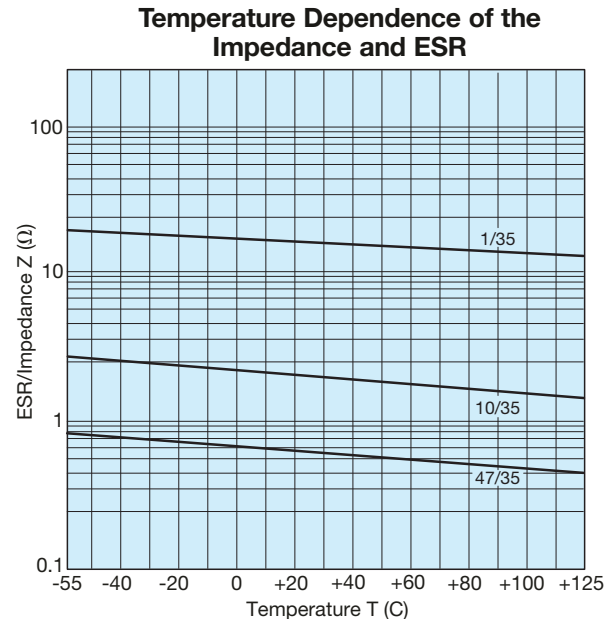

1.5 DC LEAKAGE CURRENT (DCL)

1.5.1 Leakage current (DCL)

The leakage current is dependent on the voltage applied, the time, and the capacitor temperature. It is measured at +25°C with the rated voltage applied. A protective resistance of 1000Ω is connected in series with the capacitor in the measuring circuit.

Three minutes after application of the rated voltage the leakage current must not exceed the maximum values indicated in the ratings table. Reforming is unnecessary even after prolonged periods without the application of voltage.

1.5.2 Temperature dependence of the leakage current

The leakage current increases with higher temperatures, typical values are shown in the graph.

For operation between 85°C and 125°C, the maximum working voltage must be derated and can be found from the following formula.

$$V_{\max} = \left(1 - \frac{T-85}{120}\right) \times V_R \text{ volts}$$

where T is the required operating temperature. Maximum limits are given in rating tables.

1.5.3 Voltage dependence of the leakage current

The leakage current drops rapidly below the value corresponding to the rated voltage V_R when reduced voltages are applied. The effect of voltage derating on the leakage current is shown in the graph.

This will also give a significant increase in reliability for any application. See Section 3 (pages 157-159) for details.

1.5.4 Ripple current

The maximum ripple current allowance can be calculated from the power dissipation limits for a given temperature rise above ambient. Please refer to Section 2 (page 156) for details.

Temperature Dependence of the Leakage Current for a Typical Component

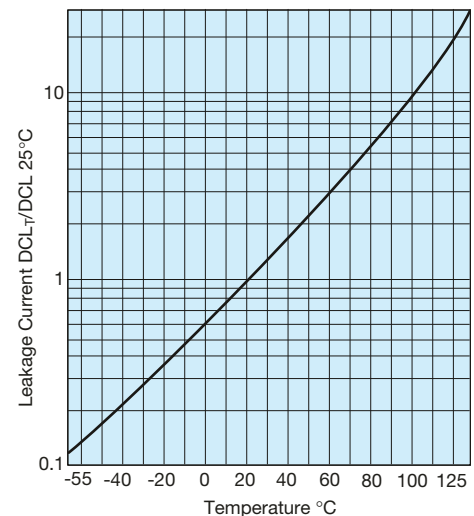

Effect of Voltage Derating on Leakage Current

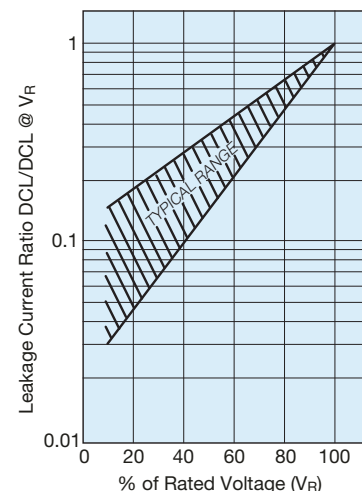

TAP/TEP Technical Summary and Application Guidelines



SECTION 2: AC OPERATION — RIPPLE VOLTAGE AND RIPPLE CURRENT

2.1 RIPPLE RATINGS (AC)

In an AC application heat is generated within the capacitor by both the AC component of the signal (which will depend upon signal form, amplitude and frequency), and by the DC leakage. For practical purposes the second factor is insignificant. The actual power dissipated in the capacitor is calculated using the formula:

$$P = I^2 R = \frac{E^2 R}{Z^2}$$

- I = rms ripple current, amperes
- R = equivalent series resistance, ohms
- E = rms ripple voltage, volts
- P = power dissipated, watts
- Z = impedance, ohms, at frequency under consideration

Using this formula it is possible to calculate the maximum AC ripple current and voltage permissible for a particular application.

2.2 MAXIMUM AC RIPPLE VOLTAGE (E_{MAX})

From the previous equation:

$$E_{(max)} = Z \sqrt{\frac{P_{max}}{R}}$$

where P_{max} is the maximum permissible ripple voltage as listed for the product under consideration (see table).

However, care must be taken to ensure that:

1. The DC working voltage of the capacitor must not be exceeded by the sum of the positive peak of the applied AC voltage and the DC bias voltage.
2. The sum of the applied DC bias voltage and the negative peak of the AC voltage must not allow a voltage reversal in excess of that defined in the sector, 'Reverse Voltage'.

2.3 MAXIMUM PERMISSIBLE POWER DISSIPATION (WATTS) @ 25°C

The maximum power dissipation at 25°C has been calculated for the various series and are shown in Section 2.4, together with temperature derating factors up to 125°C.

For leaded components the values are calculated for parts supported in air by their leads (free space dissipation).

The ripple ratings are set by defining the maximum temperature rise to be allowed under worst case conditions, i.e., with resistive losses at their maximum limit. This differential is normally 10°C at room temperature dropping to 2°C at 125°C. In application circuit layout, thermal management, available ventilation, and signal waveform may significantly

affect the values quoted below. It is recommended that temperature measurements are made on devices during operating conditions to ensure that the temperature differential between the device and the ambient temperature is less than 10°C up to 85°C and less than 2°C between 85°C and 125°C. Derating factors for temperatures above 25°C are also shown below. The maximum permissible proven dissipation should be multiplied by the appropriate derating factor.

For certain applications, e.g., power supply filtering, it may be desirable to obtain a screened level of ESR to enable higher ripple currents to be handled. Please contact our applications desk for information.

2.4 POWER DISSIPATION RATINGS (IN FREE AIR)

TAR – Molded Axial

| Case size | Max. power dissipation (W) | Temperature derating factors | |
|-----------|----------------------------|------------------------------|--------|
| | | Temp. °C | Factor |
| Q | 0.065 | +25 | 1.0 |
| R | 0.075 | +85 | 0.6 |
| S | 0.09 | +125 | 0.4 |
| W | 0.105 | | |

TAA – Hermetically Sealed Axial

| Case size | Max. power dissipation (W) | Temperature derating factors | |
|-----------|----------------------------|------------------------------|--------|
| | | Temp. °C | Factor |
| A | 0.09 | +20 | 1.0 |
| B | 0.10 | +85 | 0.9 |
| C | 0.125 | +125 | 0.4 |
| D | 0.18 | | |

TAP/TEP – Resin Dipped Radial

| Case size | Max. power dissipation (W) | Temperature derating factors | |
|-----------|----------------------------|------------------------------|--------|
| | | Temp. °C | Factor |
| A | 0.045 | +25 | 1.0 |
| B | 0.05 | +85 | 0.4 |
| C | 0.055 | +125 | 0.09 |
| D | 0.06 | | |
| E | 0.065 | | |
| F | 0.075 | | |
| G | 0.08 | | |
| H | 0.085 | | |
| J | 0.09 | | |
| K | 0.1 | | |
| L | 0.11 | | |
| M/N | 0.12 | | |
| P | 0.13 | | |
| R | 0.14 | | |



TAP/TEP Technical Summary and Application Guidelines



SECTION 3: RELIABILITY AND CALCULATION OF FAILURE RATE

3.1 STEADY-STATE

Tantalum Dielectric has essentially no wear out mechanism and in certain circumstances is capable of limited self healing, random failures can occur in operation. The failure rate of Tantalum capacitors will decrease with time and not increase as with other electrolytic capacitors and other electronic components.

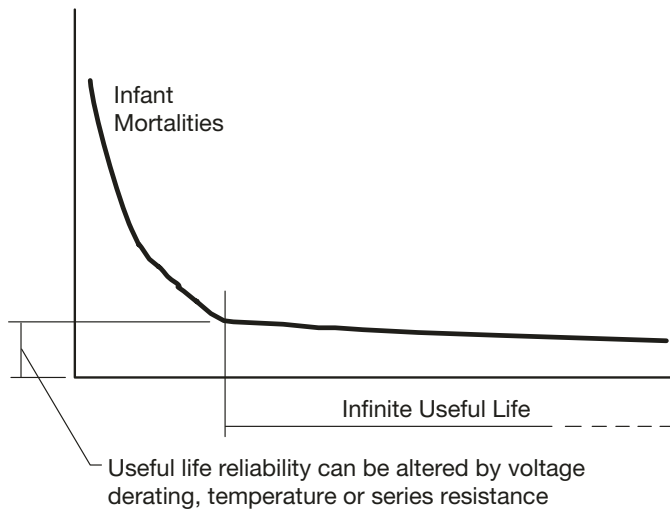

Figure 1. Tantalum reliability curve.

The useful life reliability of the Tantalum capacitor is affected by three factors. The equation from which the failure rate can be calculated is:

$$F = F_U \times F_T \times F_R \times F_B$$

where F_U is a correction factor due to operating voltage/voltage derating

F_T is a correction factor due to operating temperature

F_R is a correction factor due to circuit series resistance

F_B is the basic failure rate level. For standard leaded Tantalum product this is 1%/1000hours

Operating voltage/voltage derating

If a capacitor with a higher voltage rating than the maximum line voltage is used, then the operating reliability will be improved. This is known as voltage derating. The graph, Figure 2, shows the relationship between voltage derating (the ratio between applied and rated voltage) and the failure rate. The graph gives the correction factor F_U for any operating voltage.

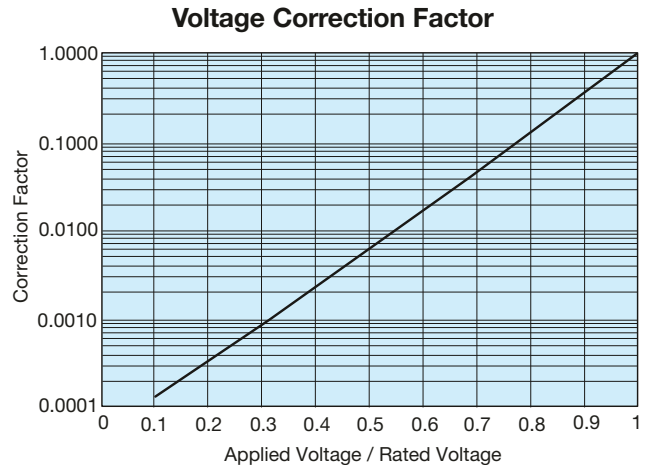

Figure 2. Correction factor to failure rate F for voltage derating of a typical component (60% con. level).

Operating temperature

If the operating temperature is below the rated temperature for the capacitor then the operating reliability will be improved as shown in Figure 3. This graph gives a correction factor F_T for any temperature of operation.

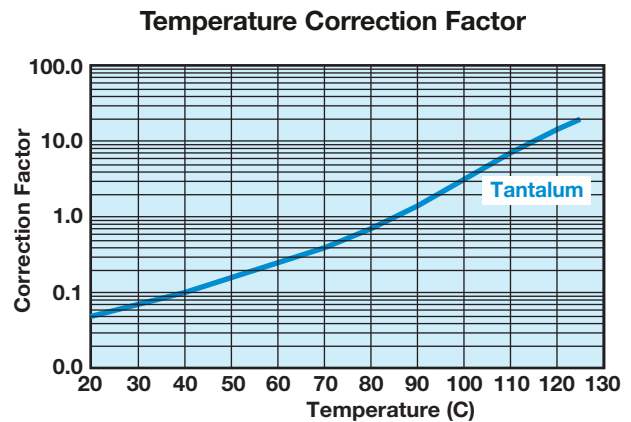

Figure 3. Correction factor to failure rate F for ambient temperature T for typical component (60% con. level).

TAP/TEP Technical Summary and Application Guidelines



Circuit Impedance

All solid tantalum capacitors require current limiting resistance to protect the dielectric from surges. A series resistor is recommended for this purpose. A lower circuit impedance may cause an increase in failure rate, especially at temperatures higher than 20°C. An inductive low impedance circuit may apply voltage surges to the capacitor and similarly a non-inductive circuit may apply current surges to the capacitor, causing localized over-heating and failure. The recommended impedance is 1Ω per volt. Where this is not feasible, equivalent voltage derating should be used (See MIL HANDBOOK 217E). Table I shows the correction factor, F_R , for increasing series resistance.

Table I: Circuit Impedance

Correction factor to failure rate F for series resistance R on basic failure rate F_B for a typical component (60% con. level).

| Circuit Resistance ohms/volt | FR |
|------------------------------|------|
| 3.0 | 0.07 |
| 2.0 | 0.1 |
| 1.0 | 0.2 |
| 0.8 | 0.3 |
| 0.6 | 0.4 |
| 0.4 | 0.6 |
| 0.2 | 0.8 |
| 0.1 | 1.0 |

Example calculation

Consider a 12 volt power line. The designer needs about 10μF of capacitance to act as a decoupling capacitor near a video bandwidth amplifier. Thus the circuit impedance will be limited only by the output impedance of the boards power unit and the track resistance. Let us assume it to be about 2 Ohms minimum, i.e., 0.167 Ohms/Volt. The operating temperature range is -25°C to +85°C. If a 10μF 16 Volt capacitor was designed-in, the operating failure rate would be as follows:

- a) $F_T = 0.8 @ 85^\circ\text{C}$
- b) $F_R = 0.7 @ 0.167 \text{ Ohms/Volt}$
- c) $F_U = 0.17 @ \text{applied voltage/rated voltage} = 75\%$

Thus $F_B = 0.8 \times 0.7 \times 0.17 \times 1 = 0.0952\%/1000 \text{ Hours}$

If the capacitor was changed for a 20 volt capacitor, the operating failure rate will change as shown.

$F_U = 0.05 @ \text{applied voltage/rated voltage} = 60\%$

$F_B = 0.8 \times 0.7 \times 0.05 \times 1 = 0.028\%/1000 \text{ Hours}$

3.2 DYNAMIC

As stated in Section 1.2.4 (page 153), the solid Tantalum capacitor has a limited ability to withstand voltage and current surges. Such current surges can cause a capacitor to fail. The expected failure rate cannot be calculated by a simple formula as in the case of steady-state reliability. The two parameters under the control of the circuit design engineer known to reduce the incidence of failures are derating and series resistance. The table below summarizes the results of trials carried out at AVX with a piece of equipment which has very low series resistance and applied no derating. So that the capacitor was tested at its rated voltage.

Results of production scale derating experiment

| Capacitance and Voltage | Number of units tested | 50% derating applied | No derating applied |
|-------------------------|------------------------|----------------------|---------------------|
| 47μF 16V | 1,547,587 | 0.03% | 1.1% |
| 100μF 10V | 632,876 | 0.01% | 0.5% |
| 22μF 25V | 2,256,258 | 0.05% | 0.3% |

As can clearly be seen from the results of this experiment, the more derating applied by the user, the less likely the probability of a surge failure occurring.

It must be remembered that these results were derived from a highly accelerated surge test machine, and failure rates in the low ppm are more likely with the end customer.

TAP/TEP Technical Summary and Application Guidelines



A commonly held misconception is that the leakage current of a Tantalum capacitor can predict the number of failures which will be seen on a surge screen. This can be disproved by the results of an experiment carried out at AVX on 47µF 10V surface mount capacitors with different leakage currents. The results are summarized in the table below.

Leakage Current vs Number of Surge Failures

| | Number tested | Number failed surge |
|---|---------------|---------------------|
| Standard leakage range 0.1 µA to 1µA | 10,000 | 25 |
| Over Catalog limit 5µA to 50µA | 10,000 | 26 |
| Classified Short Circuit 50µA to 500µA | 10,000 | 25 |

Again, it must be remembered that these results were derived from a highly accelerated surge test machine, and failure rates in the low ppm are more likely with the end customer.

AVX recommended derating table

| Voltage Rail | Working Cap Voltage |
|--------------|--------------------------|
| 3.3 | 6.3 |
| 5 | 10 |
| 10 | 20 |
| 12 | 25 |
| 15 | 35 |
| ≥24 | Series Combinations (11) |

For further details on surge in Tantalum capacitors refer to J.A. Gill's paper "Surge in Solid Tantalum Capacitors", available from AVX offices worldwide.

An added bonus of increasing the derating applied in a circuit, to improve the ability of the capacitor to withstand surge conditions, is that the steady-state reliability is improved by up to an order. Consider the example of a 6.3 volt capacitor being used on a 5 volt rail. The steady-state reliability of a Tantalum capacitor is affected by three parameters; temperature, series resistance and voltage derating. Assuming 40°C operation and 0.1Ω/volt of series resistance, the scaling factors for temperature and series resistance will both be 0.05 [see Section 3.1 (page 156)]. The derating factor will be 0.15. The capacitors reliability will therefore be

$$\begin{aligned} \text{Failure rate} &= F_U \times F_T \times F_R \times 1\%/1000 \text{ hours} \\ &= 0.15 \times 0.05 \times 1 \times 1\%/1000 \text{ hours} \\ &= 7.5\% \times 10^{-3}/\text{hours} \end{aligned}$$

If a 10 volt capacitor was used instead, the new scaling factor would be 0.017, thus the steady-state reliability would be

$$\begin{aligned} \text{Failure rate} &= F_U \times F_T \times F_R \times 1\%/1000 \text{ hours} \\ &= 0.017 \times 0.05 \times 1 \times 1\%/1000 \text{ hours} \\ &= 8.5\% \times 10^{-4}/1000 \text{ hours} \end{aligned}$$

So there is an order improvement in the capacitors steady-state reliability.

3.3 RELIABILITY TESTING

AVX performs extensive life testing on tantalum capacitors.

- 2,000 hour tests as part of our regular Quality Assurance Program.

Test conditions:

- 85°C/rated voltage/circuit impedance of 3Ω max.
- 125°C/0.67 x rated voltage/circuit impedance of 3Ω max.

3.4 Mode of Failure

This is normally an increase in leakage current which ultimately becomes a short circuit.

TAP/TEP Technical Summary and Application Guidelines



SECTION 4: APPLICATION GUIDELINES FOR TANTALUM CAPACITORS

4.1 SOLDERING CONDITIONS AND BOARD ATTACHMENT

The soldering temperature and time should be the minimum for a good connection.

A suitable combination for wavesoldering is 230°C - 250°C for 3 - 5 seconds.

Small parametric shifts may be noted immediately after wave solder, components should be allowed to stabilize at room temperature prior to electrical testing.

AVX leaded tantalum capacitors are designed for wave soldering operations.

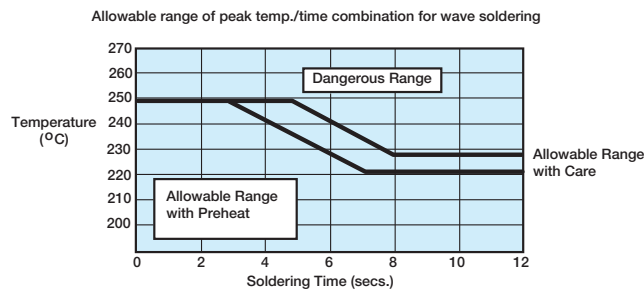

4.2 RECOMMENDED SOLDERING PROFILES

Recommended wave soldering profile for mounting of tantalum capacitors is shown below.

After soldering the assembly should preferably be allowed to cool naturally. In the event that assisted cooling is used, the rate of change in temperature should not exceed that used in reflow.

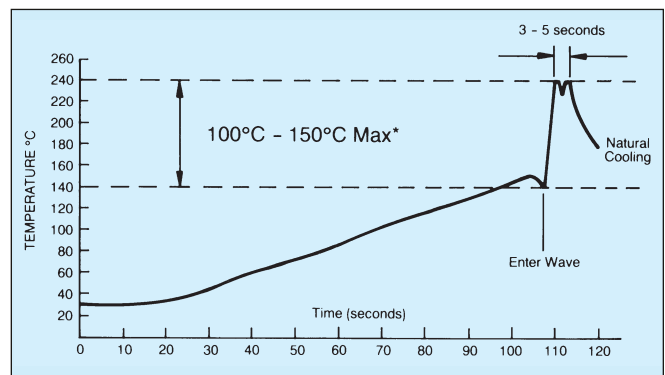

*See appropriate product specification

SECTION 5: MECHANICAL AND THERMAL PROPERTIES, LEADED CAPACITORS

5.1 ACCELERATION

10 g (981 m/s)

5.2 VIBRATION SEVERITY

10 to 2000 Hz, 0.75 mm or 98 m/s²

5.3 SHOCK

Trapezoidal Pulse 10 g (981 m/s) for 6 ms

5.4 TENSILE STRENGTH OF CONNECTION

10 N for type TAR, 5 N for type TAP/TEP.

5.5 BENDING STRENGTH OF CONNECTIONS

2 bends at 90°C with 50% of the tensile strength test loading.

5.6 SOLDERING CONDITIONS

Dip soldering permissible provided solder bath temperature $\leq 270^\circ\text{C}$; solder time < 3 sec.; circuit board thickness ≤ 1.0 mm.

5.7 INSTALLATION INSTRUCTIONS

The upper temperature limit (maximum capacitor surface temperature) must not be exceeded even under the most unfavorable conditions when the capacitor is installed. This must be considered particularly when it is positioned near components which radiate heat strongly (e.g., valves and power transistors). Furthermore, care must be taken, when bending the wires, that the bending forces do not strain the capacitor housing.

5.8 INSTALLATION POSITION

No restriction.

5.9 SOLDERING INSTRUCTIONS

Fluxes containing acids must not be used.



Technical Summary and Application Guidelines

QUESTIONS AND ANSWERS

Some commonly asked questions regarding Tantalum Capacitors:

Question: If I use several tantalum capacitors in serial/parallel combinations, how can I ensure equal current and voltage sharing?

Answer: Connecting two or more capacitors in series and parallel combinations allows almost any value and rating to be constructed for use in an application. For example, a capacitance of more than 60µF is required in a circuit for stable operation. The working voltage rail is 24 Volts dc with a superimposed ripple of 1.5 Volts at 120 Hz. The maximum voltage seen by the capacitor is $V_{dc} + V_{ac}=25.5V$

Applying the 50% derate rule tells us that a 50V capacitor is required.

Connecting two 25V rated capacitors in series will give the required capacitance voltage rating, but the effective capacitance will be halved, so for greater than



60µF, four such series combinations are required, as shown.

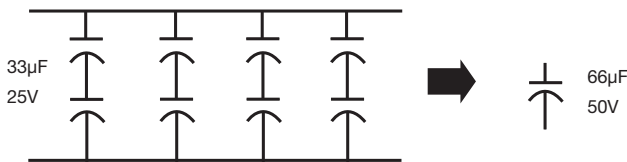

In order to ensure reliable operation, the capacitors should be connected as shown below to allow current sharing of the ac noise and ripple signals. This prevents any one capacitor heating more than its neighbors and thus being the weak link in the chain.

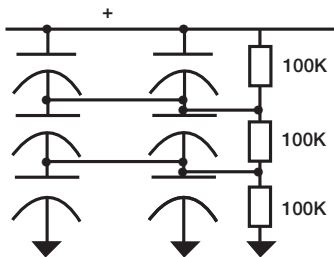

The two resistors are used to ensure that the leakage currents of the capacitors does not affect the circuit reliability, by ensuring that all the capacitors have half the working voltage across them.

Question: What are the advantages of tantalum over other capacitor technologies?

Answer:

1. Tantalums have high volumetric efficiency.
2. Electrical performance over temperature is very stable.
3. They have a wide operating temperature range -55 degrees C to +125 degrees C.
4. They have better frequency characteristics than aluminum electrolytics.
5. No wear out mechanism. Because of their construction, solid tantalum capacitors do not degrade in performance or reliability over time.

Question: If the part is rated as a 25 volt part and you have current surged it, why can't I use it at 25 volts in a low impedance circuit?

Answer: The high volumetric efficiency obtained using tantalum technology is accomplished by using an extremely thin film of tantalum pentoxide as the dielectric. Even an application of the relatively low voltage of 25 volts will produce a large field strength as seen by the dielectric. As a result of this, derating has a significant impact on reliability as described under the reliability section. The following example uses a 22 microfarad capacitor rated at 25 volts to illustrate the point. The equation for determining the amount of surface area for a capacitor is as follows:

$$C = (\epsilon (E_o) (A)) / d$$

$$A = (C (d)) / ((E_o)(\epsilon))$$

$$A = ((22 \times 10^{-6}) (170 \times 10^{-9})) / ((8.85 \times 10^{-12}) (27))$$

$$A = 0.015 \text{ square meters (150 square centimeters)}$$

Where C = Capacitance in farads

A = Dielectric (Electrode) Surface Area (m²)

d = Dielectric thickness (Space between dielectric) (m)

ε = Dielectric constant (27 for tantalum)

ε° = Dielectric Constant relative to a vacuum (8.855 x 10⁻¹² Farads x m⁻¹)

To compute the field voltage potential felt by the dielectric we use the following logic.

$$\text{Dielectric formation potential} = \text{Formation Ratio} \times \text{Working Voltage}$$

$$= 4 \times 25$$

$$\text{Formation Potential} = 100 \text{ volts}$$

Dielectric (Ta₂O₅) Thickness (d) is 1.7 x 10⁻⁹ Meters Per Volt
d = 0.17 µ meters

$$\text{Electric Field Strength} = \text{Working Voltage} / d$$

$$= (25 / 0.17 \mu \text{ meters})$$

$$= 147 \text{ Kilovolts per millimeter}$$

$$= 147 \text{ Megavolts per meter}$$

Technical Summary and Application Guidelines



QUESTIONS AND ANSWERS

No matter how pure the raw tantalum powder or the precision of processing, there will always be impurity sites in the dielectric. We attempt to stress these sites in the factory with overvoltage surges, and elevated temperature burn in so that components will fail in the factory and not in your product. Unfortunately, within this large area of tantalum pentoxide, impurity sites will exist in all capacitors. To minimize the possibility of providing enough activation energy for these impurity sites to turn from an amorphous state to a crystalline state that will conduct energy, series resistance and derating is recommended. By reducing the electric field within the anode at these sites, the tantalum capacitor has increased reliability. Tantalums differ from other electrolytics in that charge transients are carried by electronic conduction rather than absorption of ions.

Question: What negative transients can Solid Tantalum Capacitors operate under?

Answer: The reverse voltage ratings are designed to cover exceptional conditions of small level excursions into incorrect polarity. The values quoted are not intended to cover continuous reverse operation. The peak reverse voltage applied to the capacitor must not exceed:

10% of rated DC working voltage to a maximum of 1 volt at 25°C.

3% of rated DC working voltage to a maximum of 0.5 volt at 85°C.

1% of category DC working voltage to a maximum of 0.1 volt at 125°C.

Question: I have read that manufacturers recommend a series resistance of 0.1 ohm per working volt. You suggest we use 1 ohm per volt in a low impedance circuit. Why?

Answer: We are talking about two very different sets of circuit conditions for those recommendations. The 0.1 ohm per volt recommendation is for steady-state conditions. This level of resistance is used as a basis for the series resistance variable in a 1% / 1000 hours 60% confidence level reference. This is what steady-state life tests are based on. The 1 ohm per volt is recommended for dynamic conditions which include current in-rush applications such as inputs to power supply circuits. In many power supply topologies where the di/dt through the capacitor(s) is limited, (such as most implementations of buck (current mode), forward converter, and flyback), the requirement for series resistance is decreased.

Question: How long is the shelf life for a tantalum capacitor?

Answer: Solid tantalum capacitors have no limitation on shelf life. The dielectric is stable and no reformation is required. The only factors that affect future performance of the capacitors would be high humidity conditions and extreme storage temperatures. Solderability of solder coated surfaces may be affected by storage in excess of 2 years. Recommended storage conditions are: Temperature between -10°C – +50°C with humidity 75% RH maximum and atmospheric pressure 860 mbar-1060 mbar. Terminations should be checked for solderability in the event an oxidation develops on the solder plating.

Question: Are any recommendations/limitation for capacitor selection in parallel combination of capacitors?

Answer: Higher performance series TPS, TPM, NOS, NOM, TCJ, TCN are designed to provide lower ESR values and make the product more robust against current surges. The design differences make the better performance distribution of parameters, namely ESR is lower and tighter compared to the general purpose TAJ series. The surge current load in a parallel combination of capacitors is therefore shared more evenly amongst the capacitors and thus it is better suited for this application.

In a parallel combination is is strongly recommended to use the low ESR series of Tantalum Capacitors such as TPS, TPM, NOS, NOM, TCJ and TCN. Do not combine different series of manufacturers within one parallel combination.

Question: What level of voltage derating is needed for Tantalum Capacitors?

Answer: For many years whenever people have asked a tantalum capacitor manufacturer about what were the safe guidelines for using their product, they spoke with one voice "a minimum of 50% voltage derating should be applied". This message has since become ingrained and automatic. This article challenges this statement and explains why it is not necessarily the case.

The 50% rule came about when tantalum capacitors started to be used on low impedance sources. In such applications, the available current is high and therefore a risk of failure is inherent. Well established by empirical methods and covered in MIL-STD 317, was the fact that the amount of voltage derating has a major influence on the failure rate of a tantalum capacitor (Figure 1). Indeed, from rated voltage to 50% of rated voltage is an improvement in failure rate of more than 100.

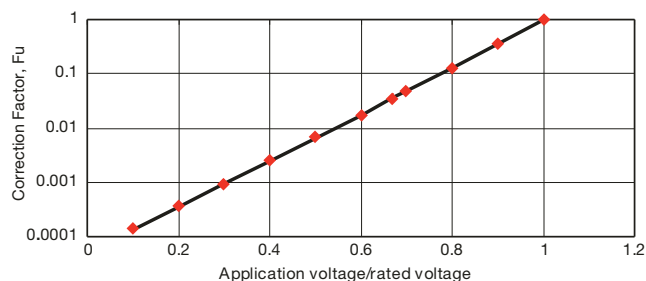
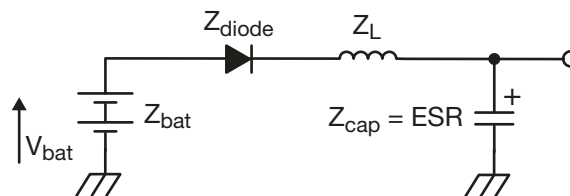

Figure 1

It was also proved that the same was true of dynamic, high current pulse conditions', hence the recommendation.

Now let us look more closely at the type of circuits in use. Below is a simple circuit which will be discussed further in this text.



Technical Summary and Application Guidelines



Let us assume this is a 2 cell battery system, therefore

$$V_{\text{bat}} = 3.2 \text{ Volts}$$

Also, let us assume

$$Z_{\text{bat}} = 60 \text{ m}\Omega, Z_{\text{diode}} = 70 \text{ m}\Omega, Z_{\text{cap}} = 120 \text{ m}\Omega, Z_L = 70 \text{ m}\Omega$$

If the “50% rule” was followed, the designer should chose a 6.3V rated capacitor.

The total circuit impedance of the system is 320 mΩ. So by Ohm’s law the peak current would be 10 Amps.

This exceeds the test conditions used by AVX to screen its product for high current pulses¹, so a risk of failure exists. Clearly a minimum of a 10 volt rate capacitor is required in this application.

As a general rule of thumb, the maximum current a tantalum capacitor can withstand (provided it has not been damaged by thermomechanical damage^{2 3} or some other external influence) is given by the equation:

$$I_{\text{max}} = V_{\text{rated}} / (1 + \text{Catalog ESR})$$

So for example for a 100μF 10V D case capacitor (Catalog ESR = 0.9 Ohms), this would be:

$$I_{\text{max}} = 10 / (1 + 0.9) = 5.2 \text{ Amps}$$

In some circuits, because of size restrictions, a tantalum capacitor may be the only option available. If this is the case, AVX recommends a PFET integrator be used to slow the voltage ramp at turn on, which in effect reduces the peak current, and therefore reduces the risk of failure⁴.

Now, let’s consider a continuation of the circuit with the addition of an LDO or DC/DC convertor.

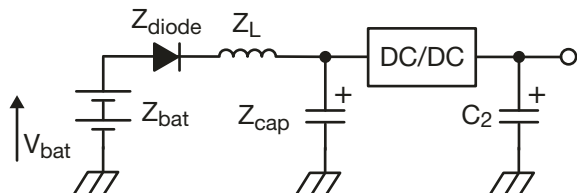

The risk of a high surge current being seen by the capacitor in location C₂ is very small. Therefore if we assume the voltage rail is 2.8 volts and the maximum current seen by C₂ is <1.5 Amps, a 4 volt capacitor could be able to be used in this application.

This all seems like good news, but as always, there are some downsides to using a part nearer to its rated voltage. The first is the steady-state life, or MTBF. The MTBF of a tantalum capacitor is easily calculated from MIL-STD 317 or the supplier’s catalog data. An example is given below:

Assume operating temperature is 85°C and circuit impedance 0.1 Ohms/volt (F_T = 1).

For a 10 volt rated capacitor on a 5 volt rated line, the failure rate is:

$$\begin{aligned} F_R &= 1\%/1000 \text{ hours} \times F_T \times F_U \times F_R \\ &= 1\%/1000 \text{ hours} \times 1 \times 0.007 \text{ (from Figure 1)} \times 1 \\ &= 0.007\%/1000 \text{ hours} \end{aligned}$$

$$\begin{aligned} \text{MTBF} &= 10^5 / F_R \\ &= 14,285,238 \text{ hours} \\ &= 1,631 \text{ years} \end{aligned}$$

For a 6.3 volt rated capacitor on a 5 volt rated line, the failure rate is:

$$\begin{aligned} F_R &= 1\%/1000 \text{ hours} \times F_T \times F_U \times F_R \\ &= 1\%/1000 \text{ hours} \times 1 \times 0.12 \text{ (from Figure 1)} \times 1 \\ &= 0.12\%/1000 \text{ hours} \end{aligned}$$

$$\begin{aligned} \text{MTBF} &= 10^5 / F_R \\ &= 833,333 \text{ hours} \\ &= 95 \text{ years} \end{aligned}$$

The second factor to be considered is that the more derating applied to a tantalum capacitor, the lower the leakage current level (Figure 2). Therefore a part used at 50% of its rated voltage will have more than 3 times better leakage levels than one used at 80%.

Leakage Current vs. Rated Voltage

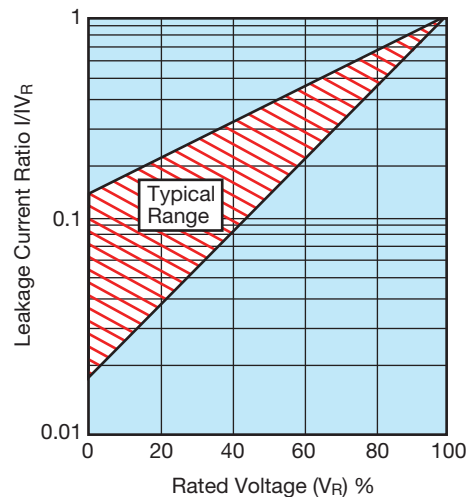

Figure 2

One final point worthy of mention with the introduction of higher reflow temperatures with the introduction of lead-free solders is that voltage derating can help to reduce the risk of failures due to thermomechanical damage during reflow.

To summarize, a tantalum capacitor is capable of being used at its rated voltage or close to it, provided that the user obeys the rules outlined in this document and is prepared for the reduced steady-state life performance and higher leakage current levels this would produce.

¹ Surge in Solid Tantalum Capacitors, John Gill, AVX Tantalum
² IR Reflow Guidelines for Tantalum Capacitors, Steve Warden & John Gill, AVX Tantalum
³ Mounting Guidelines in AVX Tantalum Catalog
⁴ Improving Reliability of Tantalum Capacitors in Low Impedance Circuits, Dave Mattingly, AVX

Technical Summary and Application Guidelines



Question: What does failure rate mean?

Answer: Failure rate is expressed as the number of parts (as a percentage) that can be expected to fail in a given time period under specific conditions of temperature, applied voltage (ratio to rated voltage - usually 1.0) and circuit impedance.

Question: What does ppm mean?

Answer: PPM is defined as 'PARTS PER MILLION' and can be used to express how many parts within a million pieces may fail to the specification.

Question: What is the difference between %/1000hrs and FITs?

Answer: The failure rate as the mathematic quantity can be expressed in several units of measurement - mostly in %/1000hrs or in FITs. FITs are usually used for the high-reliability components where expression in %/1000hrs would be more difficult to read. The conversion is as follows: e.g. 0.01%/1000hrs = 100 FIT for specified conditions ($[\%/1000\text{hrs}] = \times 10000 [\text{FIT}]$).

Question: What are the standards for reliability calculations?

Answer: The standards used in the AVX specification are based on the European norm EN 61709 with the added feature of series resistance in order to better reflect real application conditions. The basic failure rate in the AVX test is given for conditions - 85°C, Vrated, 0.1 Ohm/V. To calculate the actual failure rate for specific conditions you have to consider the influence of different factors which have an impact on reliability - correction factors for temperature (FT), voltage derating (FV), (circuit) impedance (FR) and the base failure rate (Fbase) for the series being used.

Question: Are tantalum capacitors ESD (i.e. Electrostatic Discharge) sensitive devices?

Answer: All tantalum and niobium Oxide capacitors are not ESD sensitive devices.

Select-a-Cap Software

According to given application conditions and capacitor requirements (capacitance, case size), the Select-a-Cap tool offers suitable options from AVX's extensive product range and gives an overview of capacitor ratings for each option.

INPUT PARAMETERS

- Application voltage
- Serial circuit resistance
- Maximum current coming from the power supply
- Capacitor requirements

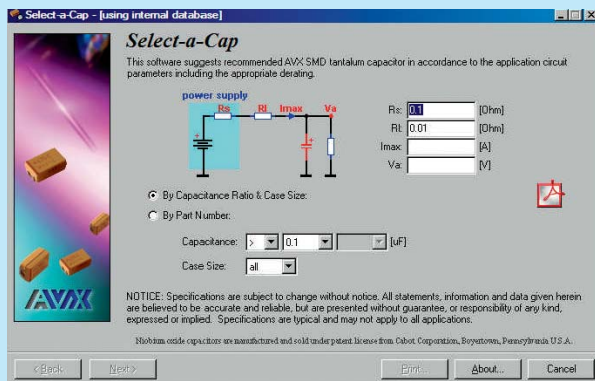

OUTPUT PARAMETERS

- Suggestion of part number
- Specification (Cap, DF, ESR, DCL)
- Max guaranteed surge current
- DCL @ application voltage
- Ripple current, ripple voltage
- Failure rate, MTBF with temperature

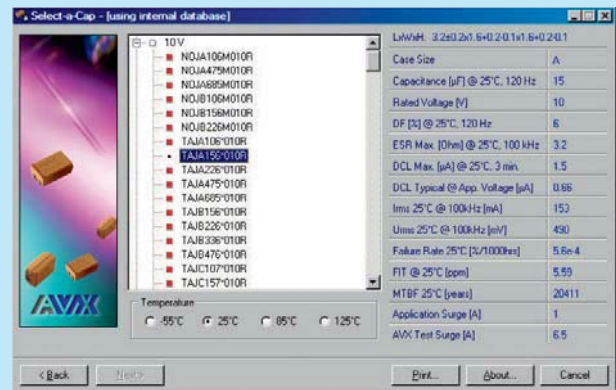

SpiTan III

Contains typical measured data of almost all released PNs and gives an overview of typical performance characteristic for tantalum and niobium oxide capacitors at different frequencies and temperatures. SpiTanIII does not contain the data from specification (for spec. limits see Select-a-Cap).

INPUT PARAMETERS

- Selected PN from the list with the help of filter (technology, capacitance, rated voltage, case, series, tolerance)

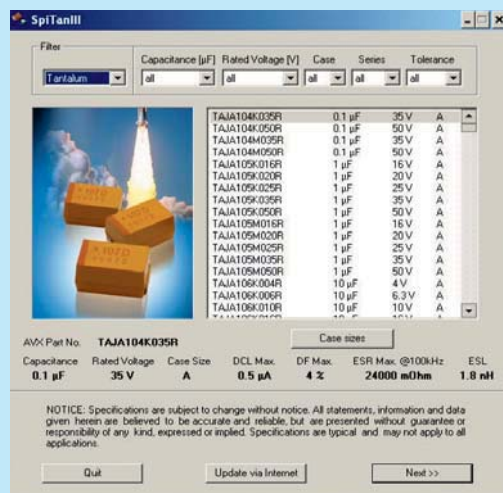

OUTPUT PARAMETERS

- Frequency characteristics of capacitance, impedance, ESR, DF for 25°C
- Temperature – shows performance according to selected operating temperature
- Frequency settings – shows values for given frequency
- Menu graph – shows additional performance figures for ripple characteristics (I,V), typical DCL performance within 5 min

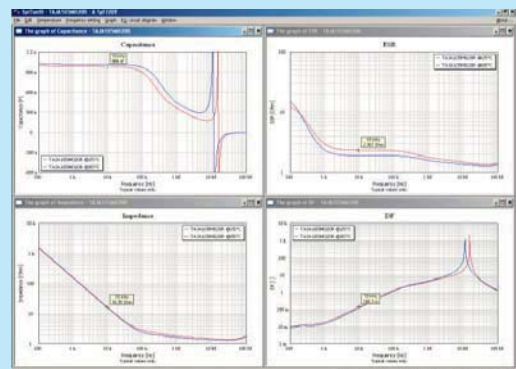

PSpice

PSpice library of tantalum capacitors suitable for high fidelity simulations with most of the PSpice software is available at AVX website.

PASSIVES

Capacitors

- Multilayer Ceramic
- Film
- Glass
- Niobium Oxide* - OxiCap®
- Pulse Supercapacitors
- Tantalum

Circuit Protection

- Thermistors
- Fuses - Thin Film
- Transient Voltage Suppressors
- Varistors - Zinc Oxide

Directional Couplers

- Thin-Film

Filters

- Ceramic
- EMI
- Noise
- SAW
- Low Pass - Thin Film

Inductors

- Thin-Film

Integrated Passive Components

- PMC - Thin-Film Networks
- Capacitor Arrays
- Feedthru Arrays
- Low Inductance Decoupling Arrays

Piezo Acoustic Generators

- Ceramic

Resistors

- Arrays
- Miniature Axials

Timing Devices

- Clock Oscillators
- MHz Quartz Crystal
- Resonators
- VCO
- TCXO

CONNECTORS

Automotive

- Standard, Custom

Board to Board

- SMD (0.4, 0.5, 1.0mm), BGA, Thru-Hole

Card Edge

DIN41612

- Standard, Inverse, High Temperature

FFC/FPC

- 0.3, 0.5, 1.0mm

Hand Held, Cellular

- Battery, I/O, SIMcard, RF shield clips

2mm Hard Metric

- Standard, Reduced Cross-Talk

IDC Wire to Board

- Headers, Plugs, Assemblies

Memory

- PCMCIA, Compact Flash, Secure Digital, MMC, Smartcard, SODIMM

Military

- H Government, DIN41612

Polytect™

- Soft Molding

Rack and Panel

- Varicon™

**For more information please visit
our website at
<http://www.avx.com>**

NOTICE: Specifications are subject to change without notice. Contact your nearest AVX Sales Office for the latest specifications. All statements, information and data given herein are believed to be accurate and reliable, but are presented without guarantee, warranty, or responsibility of any kind, expressed or implied. Statements or suggestions concerning possible use of our products are made without representation or warranty that any such use is free of patent infringement and are not recommendations to infringe any patent. The user should not assume that all safety measures are indicated or that other measures may not be required. Specifications are typical and may not apply to all applications.

© AVX Corporation

"Niobium Oxide Capacitors are manufactured and sold under patent license from Cabot Corporation, Boyertown, Pennsylvania U.S.A."

SAMPLE WALLETS:

Number of PN's: 30

Number of pieces per PN: 5

ORANGE

OxiCap®

NOJ (Sample Kit: NOJ)

NOS, NOM (Sample Kit: NOS, NOM)



SILVER

TCJ, TAJ low, TLC, NOJ, TLJ, TLN
(Sample Kit: Mobile)



BLACK

Overview of our product series and matrixes
(Kit - Series)



BLUE

TAJ Auto, TPS Auto, THJ, TRJ (Sample Kit: Automotive)

TAJ (Sample Kit: TAJ)

TPS (Sample Kit: TPS)

THJ (Sample Kit: Hi Temp THJ)

TAJ, TCJ, TLN, TPM, TPS, TRJ, NOJ
(Sample Kit: Releases)

TRJ, TRM (Sample Kit: Industrial TRJ, TRM)

TPS, TPM (Sample Kit: Low ESR)

NOS, TPM, TPS, NOM (Sample Kit: Power Supply)

TPM (Sample Kit: TPM)

TAC (Sample Kit: TAC)



PALE GREY

TLJ (Sample Kit: TLJ Low Profile)



GREEN

Military and HI-REL Capacitors

CWR19, CWR29, CWR15 and various COTS+ products
available only through the Sales or Marketing channels



YELLOW

TCJ Voltage 2V-20V (Sample Kit: TCJ)

TCJ HiV Voltage 25V-125V (Sample Kit: TCJHIV)



AMERICAS

AVX Greenville, SC
Tel: 864-967-2150

AVX Northwest, WA
Tel: 360-699-8746

AVX Midwest, IN
Tel: 317-861-9184

AVX Mid/Pacific, CA
Tel: 408-988-4900

AVX Northeast, MA
Tel: 617-479-0345

AVX Southwest, CA
Tel: 949-859-9509

AVX Canada
Tel: 905-238-3151

AVX South America
Tel: +55-11-4688-1960

EUROPE

AVX Limited, England
Tel: +44-1276-697000

AVX S.A.S., France
Tel: +33-1-69-18-46-00

AVX GmbH, Germany
Tel: +49-0811-95949-0

AVX SRL, Italy
Tel: +39-02-614-571

AVX Czech Republic
Tel: +420-57-57-57-521

AVX/ELCO UK
Tel: +44-1638-675000

ELCO Europe GmbH
Tel: +49-2741-299-0

AVX S.A., Spain
Tel: +34-91-63-97-197

AVX Benelux
Tel: +31-187-489-337

ASIA-PACIFIC

**AVX/Kyocera (S) Pte Ltd.,
Singapore**
Tel: +65-6286-7555

**AVX/Kyocera, Asia, Ltd.,
Hong Kong**
Tel: +852-2363-3303

**AVX/Kyocera Yuhan Hoesa,
South Korea**
Tel: +82-2785-6504

**AVX/Kyocera HK Ltd.,
Taiwan**
Tel: +886-2-2656-0258

**AVX/Kyocera (M) Sdn Bhd,
Malaysia**
Tel: +60-4228-1190

**AVX/Kyocera International
Trading Co. Ltd.,
Shanghai**
Tel: +86-21-3255 1933

**AVX/Kyocera Asia Ltd.,
Shenzen**
Tel: +86-755-3336-0615

**AVX/Kyocera International
Trading Co. Ltd.,
Beijing**
Tel: +86-10-6588-3528

**AVX/Kyocera India
Liaison Office**
Tel: +91-80-6450-0715

ASIA-KED

(KYOCERA Electronic Devices)

KED Hong Kong Ltd.
Tel: +852-2305-1080/1223

**KED Hong Kong Ltd.
Shenzen**
Tel: +86-755-3398-9600

**KED Company Ltd.
Shanghai**
Tel: +86-21-3255-1833

**KED Hong Kong Ltd.
Beijing**
Tel: +86-10-5869-4655

KED Taiwan Ltd.
Tel: +886-2-2950-0268

**KED Korea Yuhan Hoesa,
South Korea**
Tel: +82-2-783-3604/6126

**KED (S) Pte Ltd.
Singapore**
Tel: +65-6509-0328

**Kyocera Corporation
Japan**
Tel: +81-75-604-3449

Contact:



<http://www.avx.com>

S-TL0M613-C